

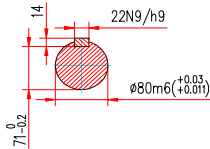

Power is our commodity, the world is our market !

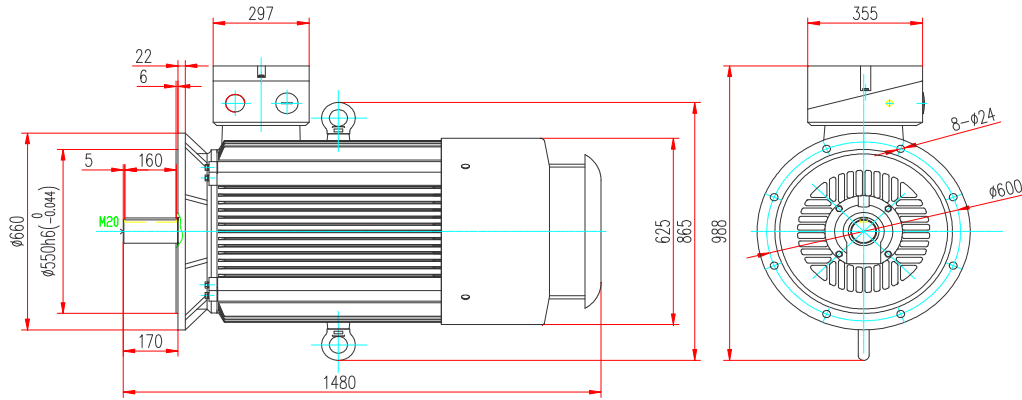

Specification	IEC60034-1
Manufacturer	Dutchi Motors BV
Motor type	DM1-IE2-315L6
Rated power	110 kW S1 Duty
Speed	985 r.p.m.
Voltage	400 / 690 V
Frequency	50 Hz
Connection	Δ / Y
Amps full load	192 / 111 A
Amps no load	62,5 A
Enclosure	IP55
Insulation class	F (temp. rise B (80 K))

Max coolant temp.	40 °C
Max altitude	1000 m above sea level
Comment	3 x PTC150 °C

Feature	Cast-iron motor
Weight	1110 kg

Warranty **12~18 months**

Efficiency class	IE2			
Load data	100%	75%	50%	25%
Efficiency	94,9	95	94,4	91,3 %
Power factor	0,86	0,84	0,76	0,57

Sound pressure level(1m)	65,9 dB(A)
Resistance R20(open)	0,029 Ω
Resistance R20	Δ 0,019 Ω

Full load torque	1060 Nm
DOL Starting torque vs FL torque	2,6
DOL Pull up torque vs FL torque	1,83
DOL Pull out torque vs FL torque	3,57
Star-Delta Starting torque vs FL torque	0,81
Star-Delta Pull up torque vs FL torque	0,57
Star-Delta Pull out torque vs FL torque	1,11
DOL Starting current vs FL current	7,66
Star-Delta Starting current vs FL current	2,39
Rotor Inertia [J]	6,15 kgm ²

Bearing DE	6319 C3
Bearing NDE	6319 C3

WI	Change	date	sign
Dutchi Motors B.V.		Description	date
P.O. Box 5390		generated	11-jun-10
NL-6802EJ Arnhem			
tel: +31-(0)26 - 3541 600		dutchi.motors@dutchi.nl	
fax: +31-(0)26 - 3541 650		www.dutchi.com	