

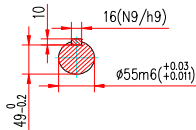

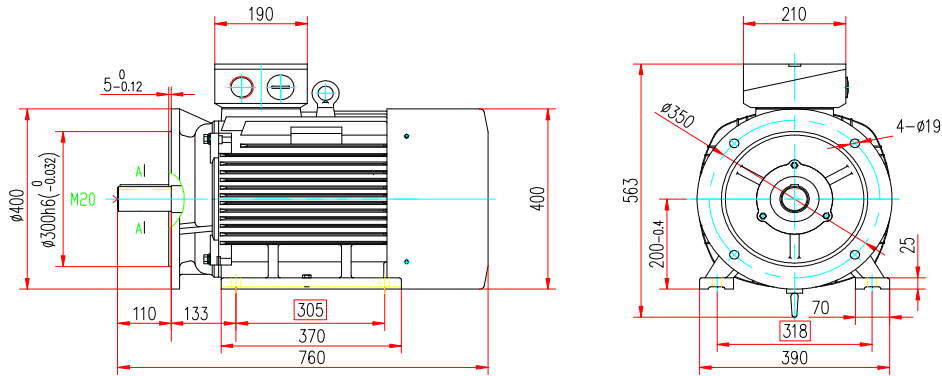

Power is our commodity, the world is our market !



Specification	<b>IEC60034-1</b>
Manufacturer	<b>Dutchi Motors BV</b>
Motor type	<b>DM1-IE2-200LX6</b>
Rated power	<b>22 kW S1</b> Duty
Speed	<b>980</b> r.p.m.
Voltage	<b>400 / 690</b> V
Frequency	<b>50</b> Hz
Connection	<b>Δ / Y</b>
Amps full load	<b>41,4 / 23,9</b> A
Amps no load	<b>17,5</b> A
Enclosure	<b>IP55</b>
Insulation class	<b>F (temp. rise B (80 K))</b>

Max coolant temp.	<b>40</b> °C
Max altitude	<b>1000</b> m above sea level
Comment	<b>3 x PTC150 °C</b>

Feature	<b>Cast-iron motor</b>
Weight	<b>225</b> kg

Warranty **12-18 months**

Efficiency class	<b>IE2</b>			
Load data	100%	75%	50%	25%
Efficiency	<b>91</b>	<b>91,5</b>	<b>90,8</b>	<b>86,4</b> %
Power factor	<b>0,83</b>	<b>0,79</b>	<b>0,69</b>	<b>0,46</b>
Sound pressure level(1m)	<b>62,4</b> dB(A)			
Resistance R20(open)	<b>0,35</b> Ω			
Resistance R20	<b>Δ 0,233</b> Ω			
Full load torque	<b>179</b> Nm			
DOL Starting torque vs FL torque	<b>2,67</b>			
DOL Pull up torque vs FL torque	<b>1,85</b>			
DOL Pull out torque vs FL torque	<b>3,36</b>			
Star-Delta Starting torque vs FL torque	<b>0,83</b>			
Star-Delta Pull up torque vs FL torque	<b>0,57</b>			
Star-Delta Pull out torque vs FL torque	<b>1,05</b>			
DOL Starting current vs FL current	<b>7,5</b>			
Star-Delta Starting current vs FL current	<b>2,34</b>			
Rotor Inertia [J]	<b>0,459</b> kgm <sup>2</sup>			
Bearing DE	<b>6312 2Z C3</b>			
Bearing NDE	<b>6312 2Z C3</b>			

WI	Change	date	sign
Dutchi Motors B.V.		Description	date
P.O. Box 5390		generated	10-jun-10
NL-6802EJ Arnhem			
tel: +31-(0)26 - 3541 600		dutchi.motors@dutchi.nl	
fax: +31-(0)26 - 3541 650		www.dutchi.com	



Power is our commodity, the world is our market !

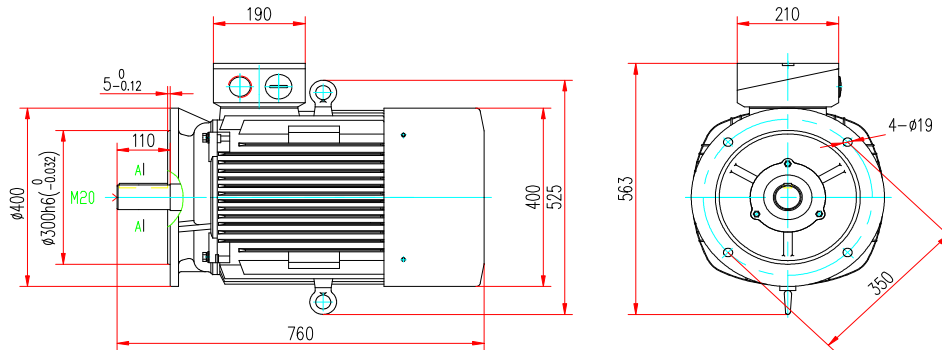

Specification	<b>IEC60034-1</b>
Manufacturer	<b>Dutchi Motors BV</b>
Motor type	<b>DM1-IE2-200LX6</b>
Rated power	<b>22 kW S1</b> Duty
Speed	<b>980</b> r.p.m.
Voltage	<b>400 / 690</b> V
Frequency	<b>50</b> Hz
Connection	<b>Δ / Y</b>
Amps full load	<b>41,4 / 23,9</b> A
Amps no load	<b>17,5</b> A
Enclosure	<b>IP55</b>
Insulation class	<b>F (temp. rise B (80 K))</b>
Max coolant temp.	<b>40</b> °C
Max altitude	<b>1000</b> m above sea level
Comment	<b>3 x PTC150 °C</b>
Feature	<b>Cast-iron motor</b>
Weight	<b>225</b> kg
Warranty	<b>12~18 months</b>

Efficiency class	<b>IE2</b>			
Load data	100%	75%	50%	25%
Efficiency	<b>91</b>	<b>91,5</b>	<b>90,8</b>	<b>86,4</b> %
Power factor	<b>0,83</b>	<b>0,79</b>	<b>0,69</b>	<b>0,46</b>
Sound pressure level(1m)	<b>62,4</b> dB(A)			
Resistance R20(open)	<b>0,35</b> Ω			
Resistance R20	<b>Δ 0,233</b> Ω			
Full load torque	<b>179</b> Nm			
DOL Starting torque vs FL torque	<b>2,67</b>			
DOL Pull up torque vs FL torque	<b>1,85</b>			
DOL Pull out torque vs FL torque	<b>3,36</b>			
Star-Delta Starting torque vs FL torque	<b>0,83</b>			
Star-Delta Pull up torque vs FL torque	<b>0,57</b>			
Star-Delta Pull out torque vs FL torque	<b>1,05</b>			
DOL Starting current vs FL current	<b>7,5</b>			
Star-Delta Starting current vs FL current	<b>2,34</b>			
Rotor Inertia [J]	<b>0,459</b> kgm <sup>2</sup>			
Bearing DE	<b>6312 2Z C3</b>			
Bearing NDE	<b>6312 2Z C3</b>			

WI	Change		date	sign
Dutchi Motors B.V. P.O. Box 5390 NL-6802EJ Arnhem tel: +31-(0)26 - 3541 600 fax: +31-(0)26 - 3541 650		Description	date	sign
		generated	10-jun-10	
dutchi.motors@dutchi.nl www.dutchi.com				

