

TRANSTECNOTM
THE MODULAR GEARMOTOR

NDCMP

NDCMP

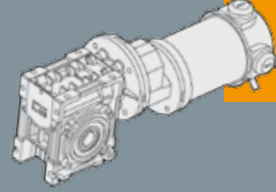

MOTORIDUTTORI C.C. CON PRECOPPIA
RARE EARTH D.C. PRE-STAGE GEARMOTORS



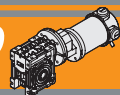

Indice	Index	Pag. Page
Caratteristiche tecniche	<i>Technical features</i>	D2
Designazione	<i>Designation</i>	D2
Simbologia	<i>Symbols</i>	D3
Lubrificazione	<i>Lubrication</i>	D3
Carichi radiali	<i>Radial loads</i>	D4
Dati tecnici	<i>Technical data</i>	D5
Motori applicabili	<i>IEC Motor adapters</i>	D5
Dimensioni	<i>Dimensions</i>	D6
Opzioni	<i>Options</i>	D8
Accessori	<i>Accessories</i>	D8

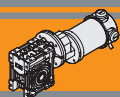

Caratteristiche tecniche

Technical features

Le caratteristiche principali dei motoriduttori a corrente continua della serie NDCMP sono:

The main features of NDCMP D.C. gearmotors range are:

- Alimentazione in bassa tensione 12/24 Vcc
 - Possibilità di montaggio encoder
 - Potenza motore disponibile 160W S2
 - Magneti in terre rare
 - Sia le carcasse dei riduttori a vite senza fine che delle precoppie sono in pressofusione di alluminio
 - Lubrificazione permanente con olio sintetico.
- Low voltage power supply 12/24 Vdc
 - Suitable for encoder assembly
 - Motor power rating available 160W S2
 - Rare earth magnets
 - Die-cast aluminum housing on pre-stage and wormgearboxes
 - Permanent synthetic oil long-life lubrication.

Designazione

Designation

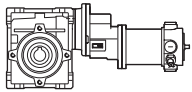
MOTORIDUTTORE / GEARMOTOR								
NDCMP	120/056/030	U	90	SZDX	BRSX	90	240	VS
Tipo Type	Grandezza Size	Versione Riduttore Gearbox Version	Rapporto Ratio	Albero di uscita Output shaft	Braccio di reazione Torque arm	Angolo Angle	Versione Motore Motor Version	Opzioni Options
NDCMP 	120/056/030 120/056/040	U FD FS FLD FLS FBD FBS	Vedere tabella See tables	SZDX SZSX DZ	BRDX BRSX	0° 90° 180° 270°	120 — 240	VS

Versione Riduttore
Gearbox Version

Albero di uscita
Output shaft

Braccio di reazione
Torque arm

Angolo
Angle

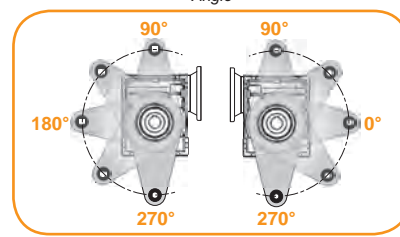
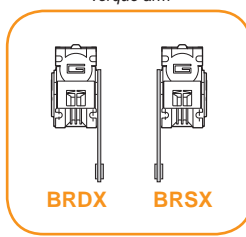
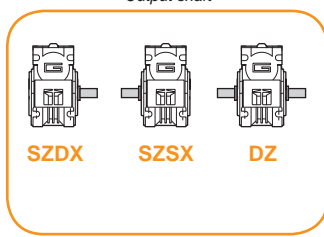
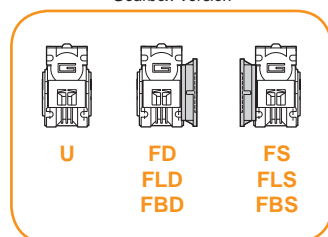

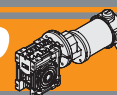

Simbologia

Symbols

n_1	[min ⁻¹]	Velocità in ingresso / <i>Input speed</i>
n_2	[min ⁻¹]	Velocità in uscita / <i>Output speed</i>
i		Rapporto di riduzione / <i>Ratio</i>
P_1	[kW]	Potenza in entrata / <i>Input power</i>

M_2	[Nm]	Coppia in uscita in funzione di P_1 / <i>Output torque referred to P_1</i>
sf		Fattore di servizio / <i>Service factor</i>
R_2	[N]	Carico radiale ammissibile in uscita / <i>Permitted output radial load</i>
A_2	[N]	Carico assiale ammissibile in uscita / <i>Permitted output axial load</i>

Lubrificazione

Lubrication

I riduttori a vite senza fine con precoppia della serie CMP sono lubrificati a vita con olio sintetico di viscosità 320 e possono essere installati in qualunque posizione di montaggio.

Permanent synthetic oil long-life lubrication allow to use CMP range in all mounting position.

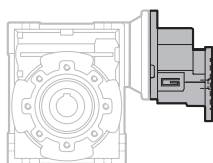

CMP	
056/030 056/040	
Lubrificazione a vita <i>Life lubricated</i>	

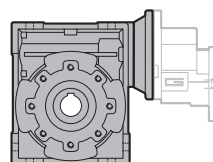

NDCMP	Quantità di olio (litri) / <i>Oil quantity (liters)</i>	
	Tutte le posizioni di montaggio / <i>For all mounting position</i>	
056/030	0.04	
056/040	0.08	

Lubrificazione a vita
Life lubricated

NDCMP

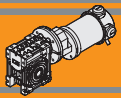

Carichi radiali

Radial loads

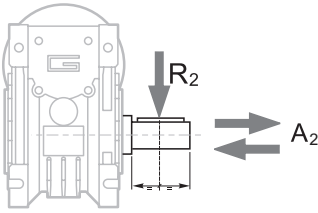

n ₂ [min ⁻¹]	R ₂ [N]	
	CM030	CM040
35	1179	2210
28	1270	2381
23	1356	2542
18	1471	2759
14	1600	3000

Quando il carico radiale risultante non è applicato sulla mezzeria dell'albero occorre calcolare quello effettivo con la seguente formula:

When the resulting radial load is not applied on the centre line of the shaft it is necessary to calculate the effective load with the following formula:

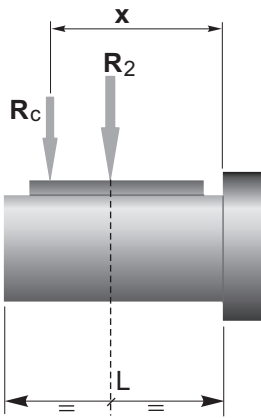

$$R_c = \frac{R_2 \cdot a}{(b + x)} \leq R_{2MAX}$$

$$R \leq R_c$$

a, b = valori riportati nella tabella
a, b = values given in the table

	CMP	
	030	040
a	65	84
b	50	64
R _{2MAX}	1600	3000

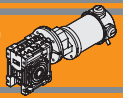

Dati tecnici per servizio S2

Technical data for S2 duty

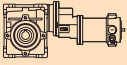
P_1 [W]	n_2 [min ⁻¹]	M_2 [Nm]	sf	i		Versione motore Motor version
160						
(3000 min ⁻¹)	50	21	1.0	60	120/056/030	120/240
	40	25	0.9	75		
	33	28	1.0	90		
	25	35	0.7	120		
	50	22	2.0	60	120/056/040	120/240
	40	26	1.7	75		
	33	30	1.9	90		
	25	36	1.3	120		
	20	43	1.1	150		
	17	48	0.9	180		
	13	55	0.7	240		
	10	51	0.7	300		

NDCMP

Motori applicabili

IEC Motor adapters

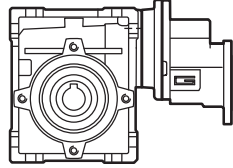
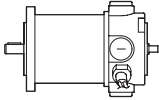
		ND
		120.120 120.240
CMP	056/030	120
	056/040	300

120 Rapporto di riduzione massimo i_{max}
Maximum ratio i_{max}

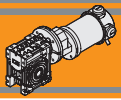

Dimensioni

Dimensions

NDCMP120/056/030 U

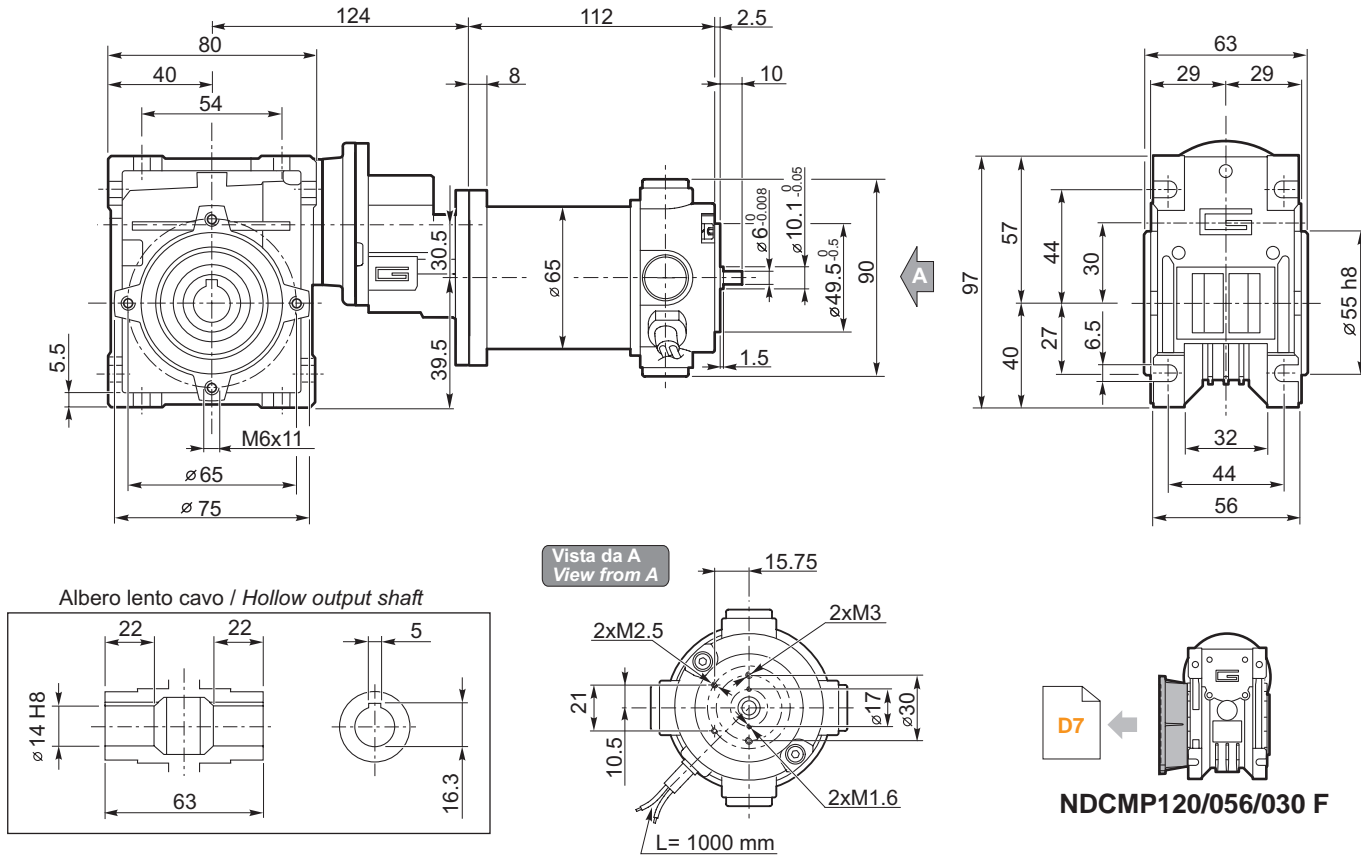

NDCMP120/056/040 U

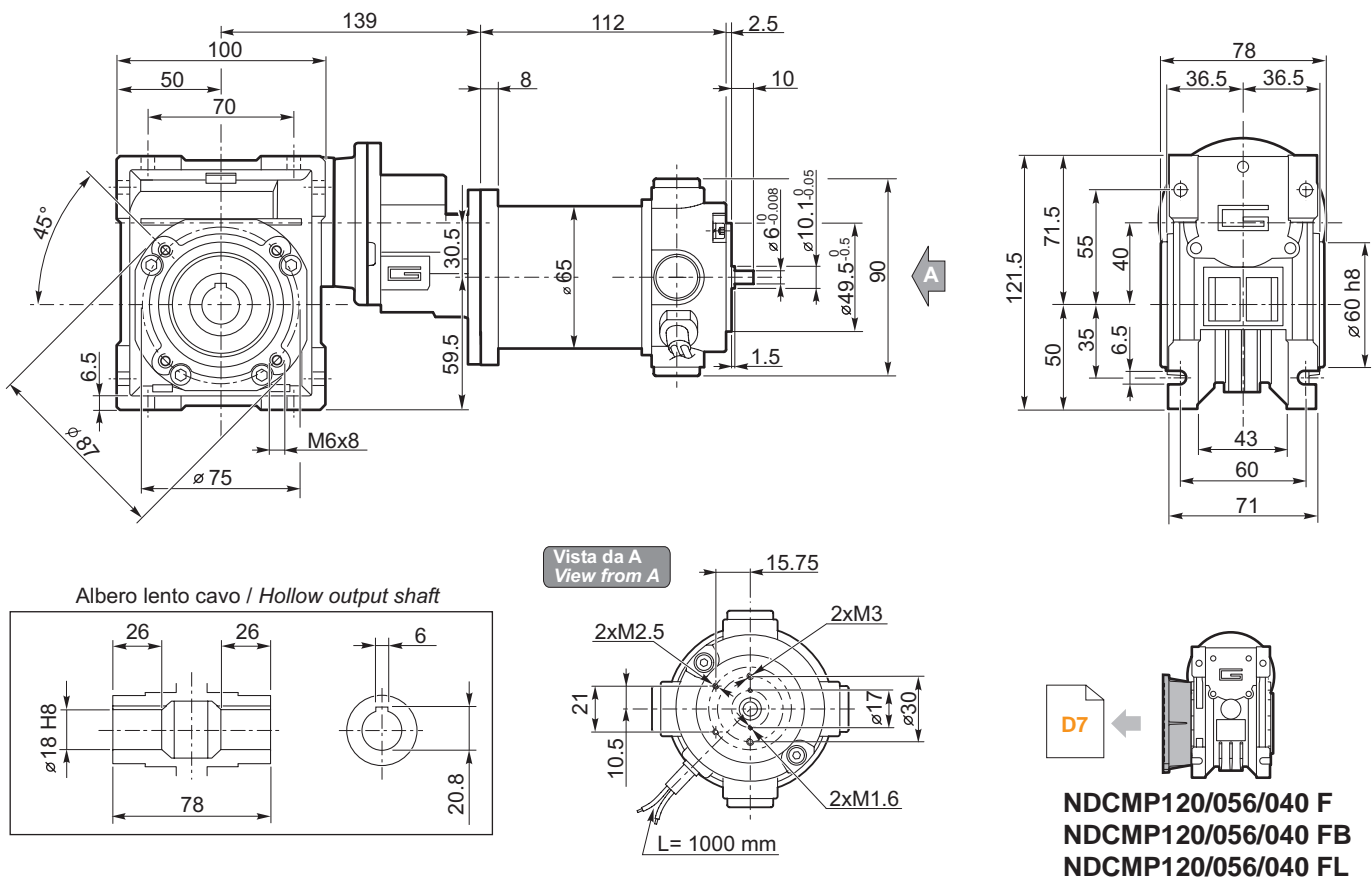

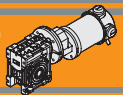

Dimensioni

Dimensions

NDCMP.../... F... Flange uscita / Output flanges

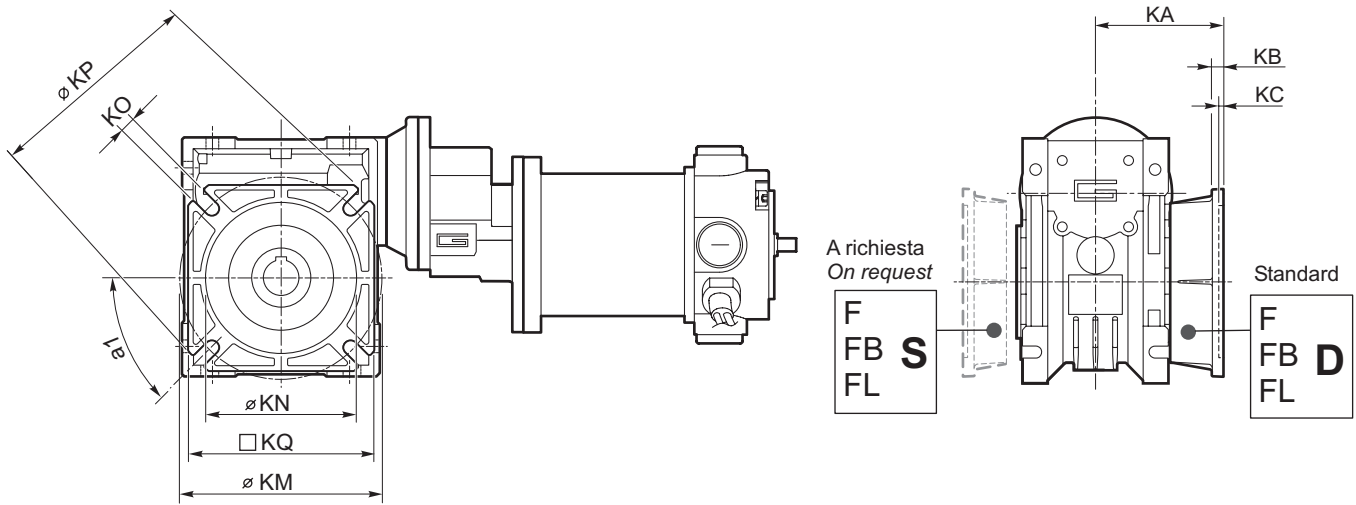

NDCMP

CMP	CMP.F							CMP.FB							CMP.FL										
	a1	KA	KB	KC	KM	KN _{H8}	KO	KP	KQ	KA	KB	KC	KM	KN _{H8}	KO	KP	KQ	KA	KB	KC	KM	KN _{H8}	KO	KP	KQ
056/030	45°	54.5	6	4	68	50	6.5(n.4)	80	70	—	—	—	—	—	—	—	—	—	—	—	—	—	—	—	—
056/040	45°	67	7.5	4.5	80-95	60	9(n.4)	110	95	80	8.5	5	115-125	95	9.5(n.4)	140	112	97	7.5	4.5	80-95	60	10(n.4)	110	95

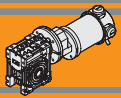

Opzioni

Options

VS - Vite sporgente / Extended input shaft

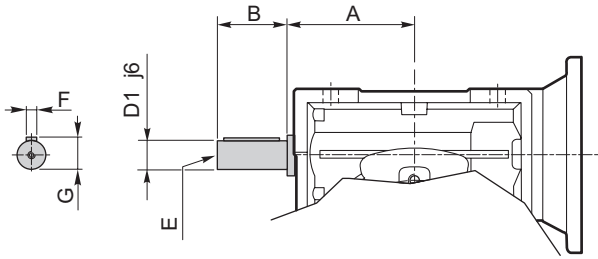

CMP	A	B	D ₁ j6	E	F	G
056/030	45	20	9	M4	3	10.2
056/040	53	23	11	M5	4	12.5

SC - Safety cover

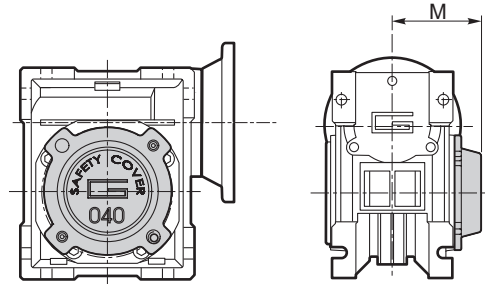

	M
CM 030	47
CM 040	54.5

Accessori

Accessories

Albero lento semplice e doppio

Single and double output shaft

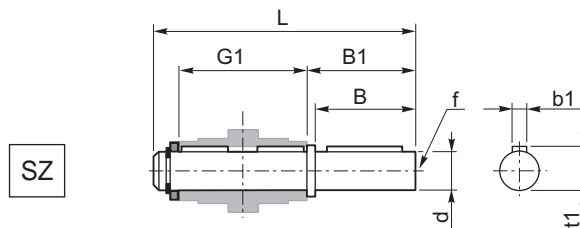
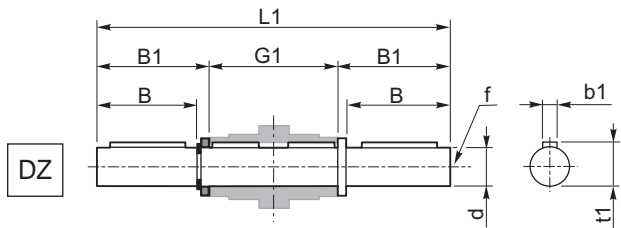

CMP	d h6	B	B1	G1	L	L1	f	b1	t1
056/030	14	30	32.5	63	102	128	M6	5	16
056/040	18	40	43	78	128	164	M6	6	20.5

Braccio di reazione

Torque arm

CMP	K1	G	KG	KH	R
056/030	85	14	23	8	15
056/040	100	14	31	10	18

