

Technischer Katalog

Planetenverstellgetriebe mit Stirnradgetriebe Serie CMGV



TRANSTECNOTM
THE MODULAR GEARMOTOR

CMGV

CMGV

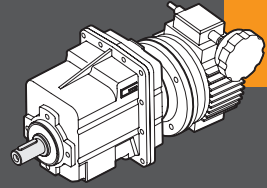

MOTOVARIARIDUTTORI AD INGRANAGGI CILINDRICI
MECHANICAL VARIATORS AND HELICAL GEARBOXES

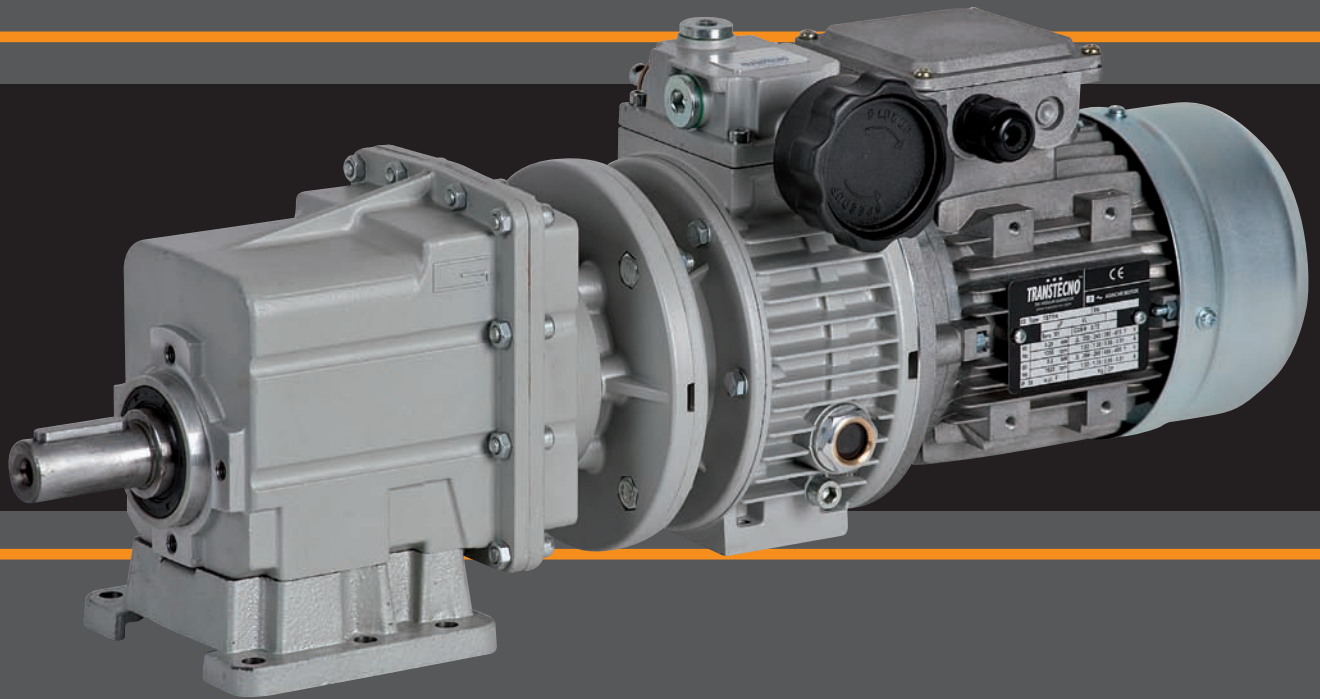

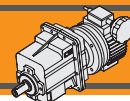

Indice	Index	Pag. Page
Caratteristiche tecniche	<i>Technical features</i>	K2
Designazione	<i>Designation</i>	K2
Versioni	<i>Versions</i>	K2
Simbologia	<i>Symbols</i>	K2
Lubrificazione	<i>Lubrication</i>	K3
Posizioni di montaggio	<i>Mounting positions</i>	K3
Carichi radiali	<i>Radial loads</i>	K4
Dati tecnici	<i>Technical data</i>	K5
Dimensioni	<i>Dimensions</i>	K10

Questa sezione annulla e sostituisce ogni precedente edizione o revisione. Qualora questa sezione non Vi sia giunta in distribuzione controllata, l'aggiornamento dei dati ivi contenuto non è assicurato. **In tal caso la versione più aggiornata è disponibile sul nostro sito internet www.transtecno.com**

*This section replaces any previous edition and revision. If you obtained this catalogue other than through controlled distribution channels, the most up to date content is not guaranteed. **In this case the latest version is available on our web site www.transtecno.com***

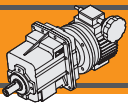

Caratteristiche tecniche

Technical features

I motovariariduttori della serie CMGV hanno le seguenti caratteristiche principali:

- Precisione nella regolazione della velocità, contenuta in $\pm 0.5/1\%$.
- Campo di regolazione continuo 1:5.
- Le grandezze CMG 00, 01, 02, 03, 04 sono costruite con carcassa in Alluminio. La grandezza 05 è costruita con carcassa in ghisa.
- Le grandezze VAM018, 037, e 075 sono costruite con carcassa in Alluminio, le altre grandezze in ghisa.

CMGV mechanical variators and helical gearboxes main features:

- Precision in speed regulation: $\pm 0.5/1\%$
- Speed range 1:5
- Die-cast aluminum housing on CMG 00, 01, 02, 03 and 04. Cast iron housing on CMG05.
- Die-cast aluminum housing on VAM018, 037 and 075. Cast iron housing on the other sizes.

Designazione

Designation

RIDUTTORE / GEARBOX				
CMGV	043/040	H75	9.81	B3/1
Tipo Type	Grandezza Size	Versione Version	Rapporto Ratio	Posizione di montaggio Mounting position
CMGV	002/018 — 043/040	U... H... F... H.../F...	vedi tabella see tables	Vedi pag. K3 See page K3

MOTORE / MOTOR				
0.37kW	4p	3ph	50Hz	T1
Potenza Power	Poli Poles	Fasi Phases	Frequenza Frequency	Pos. morsettiera Terminal box pos.
Vedi tabelle See tables	2p 4p	1ph 3ph	50Hz 60Hz	Vedi pag. K3 See page K3

Versioni

Versions

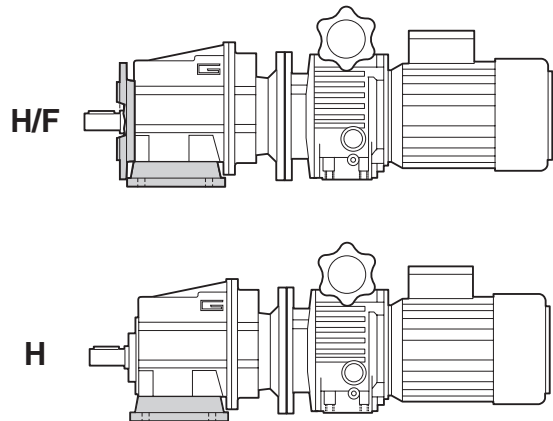
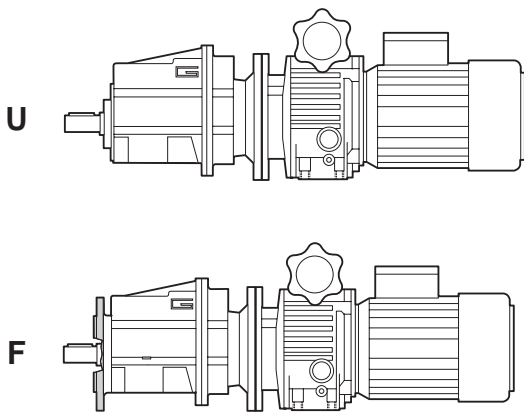

Simbologia

Symbols

n_1	[min ⁻¹]	Velocità in ingresso / <i>Input speed</i>
n_2	[min ⁻¹]	Velocità in uscita / <i>Output speed</i>
i		Rapporto di riduzione / <i>Ratio</i>
P_1	[kW]	Potenza in entrata / <i>Input power</i>
M_2	[Nm]	Coppia nominale in uscita in funzione di P_1 / <i>Output torque referred to P_1</i>
sf		Fattore di servizio / <i>Service factor</i>
R_2	[N]	Carico radiale ammissibile in uscita / <i>Permitted output radial load</i>
A_2	[N]	Carico assiale ammissibile in uscita / <i>Permitted output axial load</i>

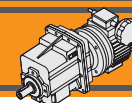

Lubrificazione

Lubrication

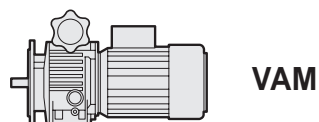
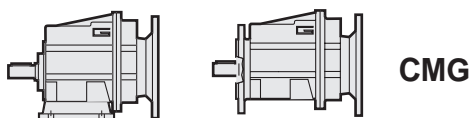

I riduttori CMG 00, 01, 02 03, 04 sono forniti completi di lubrificante, pertanto possono essere installati in qualunque posizione di montaggio e non necessitano di manutenzione. La grandezza CMG 05 è fornita completa di lubrificante per posizione B3. I variatori VAM sono forniti completi di lubrificante per posizione B3.

All CMG gear units are supplied complete with lubricant. For this reason they can be installed in any assembly position and do not require maintenance. CMG 05 is supplied filled with lubricant for B3 position. Vam are supplied filled with lubricant for B3 position.

Pos. mont. Mount. pos.	Quantità di olio (litri) / Oil quantity (liters)					
	VAM					
B3 - B5 - B6 - B7 - B8	0.15	0.20	0.35	0.80	1.2	1.2
V1 - V3 - V5 - V6	0.20	0.30	0.45	1.00	1.2	1.2

Posizioni di montaggio

Mounting positions

Versione / Version **H.. - H../F..**

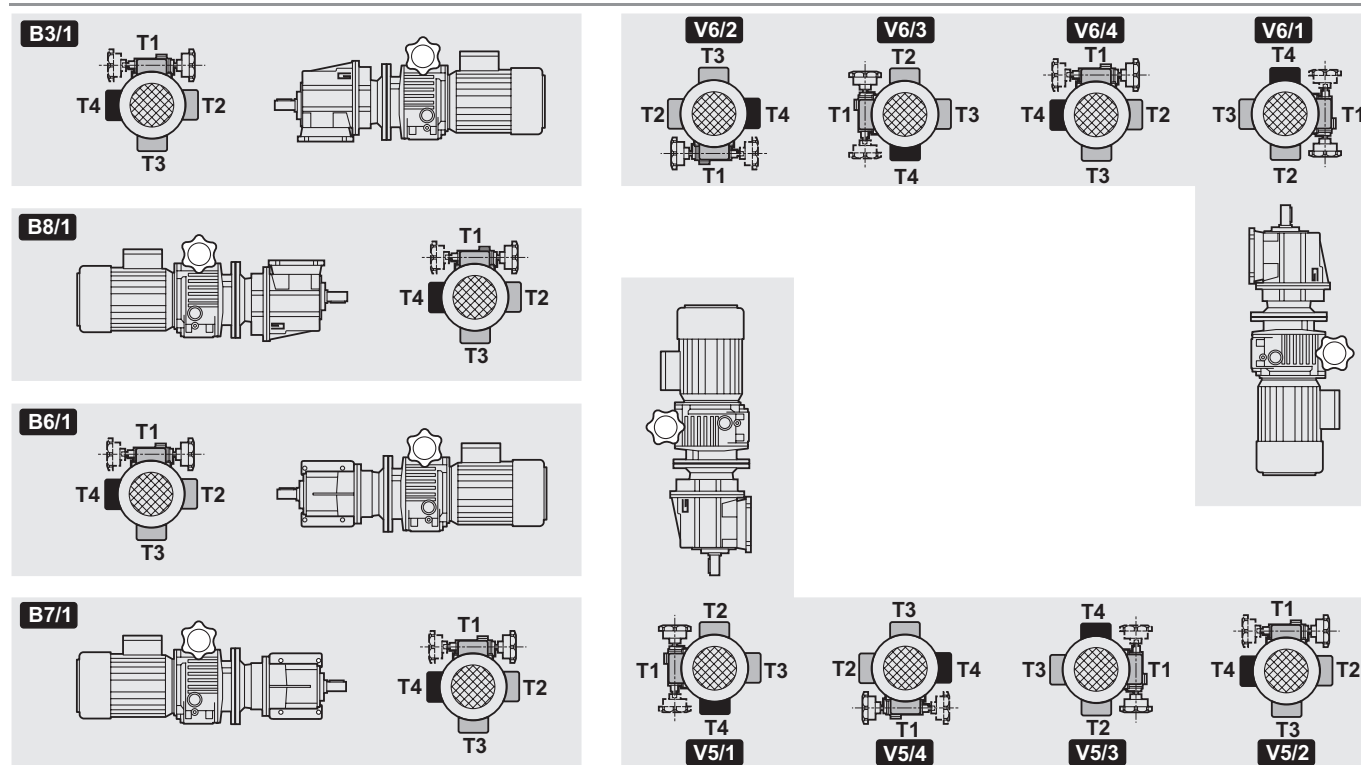

Versione / Version **U.. - F..**

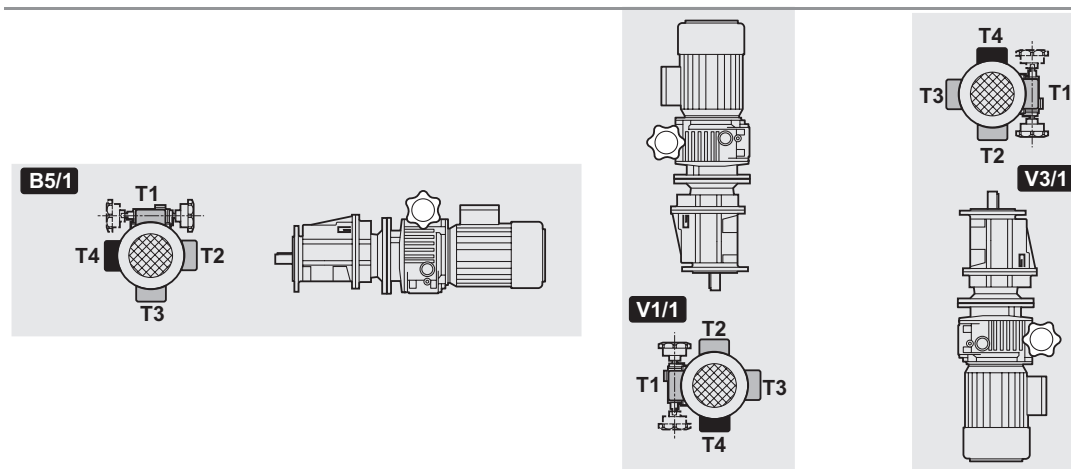

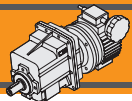

Carichi radiali

Radial loads

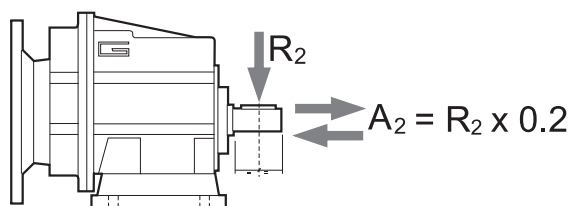

n_2 [min ⁻¹]	R_2 [N]					
	CMG 00	CMG 01	CMG 02	CMG 03	CMG 04	CMG 05
700	416	764	1529	1987	2379	3556
600	437	805	1609	2092	2504	3744
500	465	855	1710	2223	2661	3979
400	501	921	1842	2395	2866	4286
250	586	1077	2154	2801	3353	5013
180	653	1323	2554	3321	3897	5853
150	748	1406	2714	3529	4244	6392
120	806	1631	3467	3801	4572	7388
100	958	1842	3684	4507	5234	7851
80	1032	1984	3969	5042	5991	8963
60	1136	2184	4368	5549	6594	10483
40	1300	2500	5000	6500	8000	12000
10	1300	2500	5000	6500	8000	12000

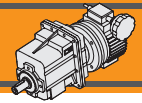

Dati tecnici

Technical data

P ₁ [kW]	velocità massima max speed			velocità minima min speed			i		P ₁ [kW]	velocità massima max speed			velocità minima min speed			i																																																																																																																																																																																																																																																																																																																																																																																																																																																																													
	n ₂ [min ⁻¹]	M ₂ [Nm]	sf	n ₂ [min ⁻¹]	M ₂ [Nm]	sf				n ₂ [min ⁻¹]	M ₂ [Nm]	sf	n ₂ [min ⁻¹]	M ₂ [Nm]	sf																																																																																																																																																																																																																																																																																																																																																																																																																																																																														
0.22									0.22																																																																																																																																																																																																																																																																																																																																																																																																																																																																																				
63C4 n ₁ =1400 [min ⁻¹]	175	9	4.9	33.8	18	2.5	5.03	CMGV 002/018	63C4 n ₁ =1400 [min ⁻¹]	9.0	174	3.2	1.7	348	1.7	97.45	CMGV 043/018																																																																																																																																																																																																																																																																																																																																																																																																																																																																												
	144	11	4.0	27.9	22	2.1	6.1			117	14	3.3	22.7	27	1.7	7.49		97.9	16	3.4	18.9	33	1.8	8.99	86.6	19	3.0	16.7	37	1.6	10.16	72.9	22	2.5	14.1	44	1.3	12.07	65.7	24	3.2	12.7	49	1.6	13.4	58.1	28	2.8	11.2	55	1.5	15.14	48.4	33	2.4	9.4	66	1.2	18.17	40.8	39	2.0	7.9	79	1.0	21.58	37.4	43	1.8	7.2	86	0.9	23.51	35.1	46	1.7	6.8	92	0.9	25.1	32.5	49	1.6	6.3	99	0.8	27.08	27.1	59	1.3	5.2	119	0.7	32.49	230	7	9.7	44.5	14	5.0	3.82	CMGV 012/018	63C2 n ₁ =2800 [min ⁻¹]	350	8	4.3	67.6	18	2.5	5.03	CMGV 002/018	190	8	8.0	36.7	17	4.1	4.63	155	10	6.5	29.9	21	3.3	5.69	114	14	6.4	22.0	28	3.3	7.72	96.0	17	5.4	18.5	33	2.8	9.17	89.7	18	5.0	17.3	36	2.6	9.81	76.5	21	5.3	14.8	42	2.7	11.50	73.9	22	5.2	14.3	43	2.6	11.90	63.8	25	5.3	12.3	50	2.7	13.80	60.2	27	5.0	11.6	53	2.6	14.62	49.3	33	4.1	9.5	65	2.1	17.86	46.1	35	3.9	8.9	70	2.0	19.07	44.4	36	3.7	8.6	72	1.9	19.83	37.4	43	3.1	7.2	86	1.6	23.56	29.8	54	2.5	5.8	108	1.3	29.56	24.8	65	2.1	4.8	129	1.1	35.47	19.2	84	1.6	3.7	167	0.8	45.89	18.0	89	1.5	3.5	179	0.8	49.00	16.5	97	1.4	3.2	195	0.7	53.33	18.9	83	1.6	3.6	166	0.8	46.61	CMGV 013/018	461	6	8.6	89.0	14	5.0	3.82	CMGV 012/018	15.9	99	1.4	3.1	198	0.7	55.36	13.9	113	1.2	2.7	226	0.6	63.22	18.6	84	2.7	3.6	169	1.4	47.19	CMGV 023/018	380	8	7.1	73.4	17	4.1	4.63	15.7	100	2.2	3.0	200	1.1	56.05	13.7	114	2.0	2.7	229	1.0	64.01	11.6	136	1.6	2.2	272	0.8	76.02	9.7	161	1.4	1.9	323	0.7	90.29	7.7	204	1.1	1.5	409	0.6	114.46	19.5	81	4.2	3.8	161	2.1	45.21	CMGV 033/018	309	9	5.8	59.8	21	3.3	5.69	14.4	110	3.1	2.8	219	1.6	61.32	12.1	130	2.6	2.3	260	1.3	72.83	9.0	174	1.9	1.7	348	1.0	97.45	7.6	207	1.6	1.5	413	0.8	115.74	6.2	251	1.3	1.2	503	0.7	140.81	5.0	311	1.1	1.0	622	0.6	174.26	37.8	74	1.4	7.3	166	0.8	46.61	CMGV 013/018	228	13	5.7	44.0	28	3.3	7.72	31.8	88	1.2	6.1	198	0.7	55.36	27.8	101	1.1	5.4	226	0.6	63.22	37.3	75	2.4	7.2	169	1.4	47.19	CMGV 023/018	192	15	4.8	37.1	33	2.8	9.17	31.4	90	2.0	6.1	200	1.1	56.05	27.5	102	1.7	5.3	229	1.0	64.01	23.2	121	1.5	4.5	272	0.8	76.02	19.5	144	1.2	3.8	323	0.7	90.29	15.4	183	1.0	3.0	409	0.6	114.46																								
	117	14	3.3	22.7	27	1.7	7.49			97.9	16	3.4	18.9	33	1.8	8.99		86.6	19	3.0	16.7	37	1.6	10.16	72.9	22	2.5	14.1	44	1.3	12.07	65.7	24	3.2	12.7	49	1.6	13.4	58.1	28	2.8	11.2	55	1.5	15.14	48.4	33	2.4	9.4	66	1.2	18.17	40.8	39	2.0	7.9	79	1.0	21.58	37.4	43	1.8	7.2	86	0.9	23.51	35.1	46	1.7	6.8	92	0.9	25.1	32.5	49	1.6	6.3	99	0.8	27.08	27.1	59	1.3	5.2	119	0.7	32.49	230	7	9.7	44.5	14	5.0	3.82	CMGV 012/018	63C2 n ₁ =2800 [min ⁻¹]	350	8	4.3	67.6	18			2.5	5.03	CMGV 002/018	190	8	8.0	36.7		17	4.1	4.63	155	10	6.5	29.9	21	3.3	5.69	114	14	6.4	22.0	28	3.3	7.72	96.0	17	5.4	18.5	33	2.8	9.17	89.7	18	5.0	17.3	36	2.6	9.81	76.5	21	5.3	14.8	42	2.7	11.50	73.9	22	5.2	14.3	43	2.6	11.90	63.8	25	5.3	12.3	50	2.7	13.80	60.2	27	5.0	11.6	53	2.6	14.62	49.3	33	4.1	9.5	65	2.1	17.86	46.1	35	3.9	8.9	70	2.0	19.07	44.4	36	3.7	8.6	72	1.9	19.83	37.4	43	3.1	7.2	86	1.6	23.56	29.8	54	2.5	5.8	108	1.3	29.56	24.8	65	2.1	4.8	129	1.1	35.47	19.2	84	1.6	3.7	167	0.8	45.89	18.0	89	1.5	3.5	179	0.8	49.00	16.5	97	1.4	3.2	195	0.7	53.33	18.9	83	1.6	3.6	166	0.8	46.61	CMGV 013/018	461	6	8.6		89.0	14	5.0	3.82	CMGV 012/018	15.9	99		1.4	3.1	198	0.7	55.36	13.9	113	1.2	2.7	226	0.6	63.22	18.6	84	2.7	3.6	169	1.4	47.19	CMGV 023/018	380		8	7.1	73.4	17	4.1	4.63	15.7	100	2.2	3.0	200	1.1	56.05	13.7	114	2.0	2.7	229	1.0	64.01	11.6	136	1.6	2.2	272	0.8	76.02	9.7	161	1.4	1.9	323	0.7	90.29	7.7	204	1.1	1.5	409	0.6	114.46	19.5	81	4.2	3.8	161	2.1	45.21	CMGV 033/018		309	9	5.8	59.8	21	3.3	5.69	14.4	110	3.1	2.8	219	1.6	61.32	12.1	130	2.6	2.3	260	1.3	72.83	9.0	174	1.9	1.7	348	1.0	97.45	7.6	207	1.6	1.5	413	0.8	115.74	6.2	251	1.3	1.2	503	0.7	140.81	5.0	311	1.1	1.0	622	0.6	174.26	37.8	74	1.4	7.3	166	0.8	46.61		CMGV 013/018	228	13	5.7	44.0	28	3.3	7.72	31.8	88	1.2	6.1	198	0.7	55.36	27.8	101	1.1	5.4	226	0.6	63.22	37.3	75	2.4	7.2	169	1.4		47.19	CMGV 023/018	192	15	4.8	37.1	33	2.8	9.17	31.4	90	2.0	6.1	200	1.1	56.05	27.5	102	1.7	5.3	229	1.0	64.01	23.2	121	1.5	4.5	272	0.8	76.02	19.5	144	1.2	3.8	323	0.7	90.29	15.4	183	1.0	3.0	409	0.6	114.46																						
	97.9	16	3.4	18.9	33	1.8	8.99			86.6	19	3.0	16.7	37	1.6	10.16		72.9	22	2.5	14.1	44	1.3	12.07	65.7	24	3.2	12.7	49	1.6	13.4	58.1	28	2.8	11.2	55	1.5	15.14	48.4	33	2.4	9.4	66	1.2	18.17	40.8	39	2.0	7.9	79	1.0	21.58	37.4	43	1.8	7.2	86	0.9	23.51	35.1	46	1.7	6.8	92	0.9	25.1	32.5	49	1.6	6.3	99	0.8	27.08	27.1	59	1.3	5.2	119	0.7	32.49	230	7	9.7	44.5	14	5.0	3.82	CMGV 012/018	63C2 n ₁ =2800 [min ⁻¹]	350	8	4.3	67.6	18			2.5	5.03	CMGV 002/018	190	8			8.0	36.7		17	4.1	4.63	155		10	6.5	29.9	21	3.3	5.69	114	14	6.4	22.0	28	3.3	7.72	96.0	17	5.4	18.5	33	2.8	9.17	89.7	18	5.0	17.3	36	2.6	9.81	76.5	21	5.3	14.8	42	2.7	11.50	73.9	22	5.2	14.3	43	2.6	11.90	63.8	25	5.3	12.3	50	2.7	13.80	60.2	27	5.0	11.6	53	2.6	14.62	49.3	33	4.1	9.5	65	2.1	17.86	46.1	35	3.9	8.9	70	2.0	19.07	44.4	36	3.7	8.6	72	1.9	19.83	37.4	43	3.1	7.2	86	1.6	23.56	29.8	54	2.5	5.8	108	1.3	29.56	24.8	65	2.1	4.8	129	1.1	35.47	19.2	84	1.6	3.7	167	0.8	45.89	18.0	89	1.5	3.5	179	0.8	49.00	16.5	97	1.4	3.2	195	0.7	53.33	18.9	83	1.6	3.6	166	0.8	46.61	CMGV 013/018	461	6	8.6		89.0	14	5.0		3.82	CMGV 012/018	15.9	99		1.4	3.1		198	0.7	55.36	13.9	113	1.2	2.7	226	0.6	63.22	18.6	84	2.7	3.6	169	1.4	47.19	CMGV 023/018	380		8		7.1	73.4	17	4.1	4.63	15.7	100	2.2	3.0	200	1.1	56.05	13.7	114	2.0	2.7	229	1.0	64.01	11.6	136	1.6	2.2	272	0.8	76.02	9.7	161	1.4	1.9	323	0.7	90.29	7.7	204	1.1	1.5	409	0.6	114.46	19.5	81	4.2	3.8	161	2.1	45.21	CMGV 033/018			309	9	5.8	59.8	21	3.3	5.69	14.4	110	3.1	2.8	219	1.6	61.32	12.1	130	2.6	2.3	260	1.3	72.83	9.0	174	1.9	1.7	348	1.0	97.45	7.6	207	1.6	1.5	413	0.8	115.74	6.2	251	1.3	1.2	503	0.7	140.81	5.0	311	1.1	1.0	622	0.6	174.26	37.8	74	1.4	7.3	166	0.8	46.61			CMGV 013/018	228	13	5.7	44.0	28	3.3	7.72	31.8	88	1.2	6.1	198	0.7	55.36	27.8	101	1.1	5.4	226	0.6	63.22	37.3	75	2.4	7.2	169		1.4		47.19	CMGV 023/018	192	15	4.8	37.1	33	2.8	9.17	31.4	90	2.0	6.1	200	1.1	56.05	27.5	102	1.7	5.3	229	1.0	64.01	23.2	121	1.5	4.5	272	0.8	76.02	19.5	144	1.2	3.8	323	0.7	90.29	15.4	183	1.0	3.0	409	0.6	114.46																				
	86.6	19	3.0	16.7	37	1.6	10.16			72.9	22	2.5	14.1	44	1.3	12.07		65.7	24	3.2	12.7	49	1.6	13.4	58.1	28	2.8	11.2	55	1.5	15.14	48.4	33	2.4	9.4	66	1.2	18.17	40.8	39	2.0	7.9	79	1.0	21.58	37.4	43	1.8	7.2	86	0.9	23.51	35.1	46	1.7	6.8	92	0.9	25.1	32.5	49	1.6	6.3	99	0.8	27.08	27.1	59	1.3	5.2	119	0.7	32.49	230	7	9.7	44.5	14	5.0	3.82	CMGV 012/018	63C2 n ₁ =2800 [min ⁻¹]	350	8	4.3	67.6	18			2.5	5.03	CMGV 002/018	190	8			8.0	36.7		17	4.1			4.63	155		10	6.5	29.9	21		3.3	5.69	114	14	6.4	22.0	28	3.3	7.72	96.0	17	5.4	18.5	33	2.8	9.17	89.7	18	5.0	17.3	36	2.6	9.81	76.5	21	5.3	14.8	42	2.7	11.50	73.9	22	5.2	14.3	43	2.6	11.90	63.8	25	5.3	12.3	50	2.7	13.80	60.2	27	5.0	11.6	53	2.6	14.62	49.3	33	4.1	9.5	65	2.1	17.86	46.1	35	3.9	8.9	70	2.0	19.07	44.4	36	3.7	8.6	72	1.9	19.83	37.4	43	3.1	7.2	86	1.6	23.56	29.8	54	2.5	5.8	108	1.3	29.56	24.8	65	2.1	4.8	129	1.1	35.47	19.2	84	1.6	3.7	167	0.8	45.89	18.0	89	1.5	3.5	179	0.8	49.00	16.5	97	1.4	3.2	195	0.7	53.33	18.9	83	1.6	3.6	166	0.8	46.61	CMGV 013/018	461	6	8.6		89.0	14	5.0		3.82	CMGV 012/018	15.9		99		1.4	3.1		198	0.7		55.36	13.9	113	1.2	2.7	226	0.6	63.22	18.6	84	2.7	3.6	169	1.4	47.19	CMGV 023/018	380		8		7.1		73.4	17	4.1	4.63	15.7	100	2.2	3.0	200	1.1	56.05	13.7	114	2.0	2.7	229	1.0	64.01	11.6	136	1.6	2.2	272	0.8	76.02	9.7	161	1.4	1.9	323	0.7	90.29	7.7	204	1.1	1.5	409	0.6	114.46	19.5	81	4.2	3.8	161	2.1	45.21	CMGV 033/018				309	9	5.8	59.8	21	3.3	5.69	14.4	110	3.1	2.8	219	1.6	61.32	12.1	130	2.6	2.3	260	1.3	72.83	9.0	174	1.9	1.7	348	1.0	97.45	7.6	207	1.6	1.5	413	0.8	115.74	6.2	251	1.3	1.2	503	0.7	140.81	5.0	311	1.1	1.0	622	0.6	174.26	37.8	74	1.4	7.3	166	0.8	46.61				CMGV 013/018	228	13	5.7	44.0	28	3.3	7.72	31.8	88	1.2	6.1	198	0.7	55.36	27.8	101	1.1	5.4	226	0.6	63.22	37.3	75	2.4	7.2		169		1.4		47.19	CMGV 023/018	192	15	4.8	37.1	33	2.8	9.17	31.4	90	2.0	6.1	200	1.1	56.05	27.5	102	1.7	5.3	229	1.0	64.01	23.2	121	1.5	4.5	272	0.8	76.02	19.5	144	1.2	3.8	323	0.7	90.29	15.4	183	1.0	3.0	409	0.6	114.46																		
	72.9	22	2.5	14.1	44	1.3	12.07			65.7	24	3.2	12.7	49	1.6	13.4		58.1	28	2.8	11.2	55	1.5	15.14	48.4	33	2.4	9.4	66	1.2	18.17	40.8	39	2.0	7.9	79	1.0	21.58	37.4	43	1.8	7.2	86	0.9	23.51	35.1	46	1.7	6.8	92	0.9	25.1	32.5	49	1.6	6.3	99	0.8	27.08	27.1	59	1.3	5.2	119	0.7	32.49	230	7	9.7	44.5	14	5.0	3.82	CMGV 012/018	63C2 n ₁ =2800 [min ⁻¹]	350	8	4.3	67.6	18			2.5	5.03	CMGV 002/018	190	8			8.0	36.7		17	4.1			4.63	155		10	6.5			29.9	21		3.3	5.69	114	14		6.4	22.0	28	3.3	7.72	96.0	17	5.4	18.5	33	2.8	9.17	89.7	18	5.0	17.3	36	2.6	9.81	76.5	21	5.3	14.8	42	2.7	11.50	73.9	22	5.2	14.3	43	2.6	11.90	63.8	25	5.3	12.3	50	2.7	13.80	60.2	27	5.0	11.6	53	2.6	14.62	49.3	33	4.1	9.5	65	2.1	17.86	46.1	35	3.9	8.9	70	2.0	19.07	44.4	36	3.7	8.6	72	1.9	19.83	37.4	43	3.1	7.2	86	1.6	23.56	29.8	54	2.5	5.8	108	1.3	29.56	24.8	65	2.1	4.8	129	1.1	35.47	19.2	84	1.6	3.7	167	0.8	45.89	18.0	89	1.5	3.5	179	0.8	49.00	16.5	97	1.4	3.2	195	0.7	53.33	18.9	83	1.6	3.6	166	0.8	46.61	CMGV 013/018	461	6	8.6		89.0	14	5.0		3.82	CMGV 012/018	15.9		99		1.4		3.1		198	0.7		55.36	13.9		113	1.2	2.7	226	0.6	63.22	18.6	84	2.7	3.6	169	1.4	47.19	CMGV 023/018	380		8		7.1		73.4		17	4.1	4.63	15.7	100	2.2	3.0	200	1.1	56.05	13.7	114	2.0	2.7	229	1.0	64.01	11.6	136	1.6	2.2	272	0.8	76.02	9.7	161	1.4	1.9	323	0.7	90.29	7.7	204	1.1	1.5	409	0.6	114.46	19.5	81	4.2	3.8	161	2.1	45.21	CMGV 033/018					309	9	5.8	59.8	21	3.3	5.69	14.4	110	3.1	2.8	219	1.6	61.32	12.1	130	2.6	2.3	260	1.3	72.83	9.0	174	1.9	1.7	348	1.0	97.45	7.6	207	1.6	1.5	413	0.8	115.74	6.2	251	1.3	1.2	503	0.7	140.81	5.0	311	1.1	1.0	622	0.6	174.26	37.8	74	1.4	7.3	166	0.8	46.61					CMGV 013/018	228	13	5.7	44.0	28	3.3	7.72	31.8	88	1.2	6.1	198	0.7	55.36	27.8	101	1.1	5.4	226	0.6	63.22	37.3	75	2.4		7.2		169		1.4		47.19	CMGV 023/018	192	15	4.8	37.1	33	2.8	9.17	31.4	90	2.0	6.1	200	1.1	56.05	27.5	102	1.7	5.3	229	1.0	64.01	23.2	121	1.5	4.5	272	0.8	76.02	19.5	144	1.2	3.8	323	0.7	90.29	15.4	183	1.0	3.0	409	0.6	114.46																
	65.7	24	3.2	12.7	49	1.6	13.4			58.1	28	2.8	11.2	55	1.5	15.14		48.4	33	2.4	9.4	66	1.2	18.17	40.8	39	2.0	7.9	79	1.0	21.58	37.4	43	1.8	7.2	86	0.9	23.51	35.1	46	1.7	6.8	92	0.9	25.1	32.5	49	1.6	6.3	99	0.8	27.08	27.1	59	1.3	5.2	119	0.7	32.49	230	7	9.7	44.5	14	5.0	3.82	CMGV 012/018	63C2 n ₁ =2800 [min ⁻¹]	350	8	4.3	67.6	18			2.5	5.03	CMGV 002/018	190	8			8.0	36.7		17	4.1			4.63	155		10	6.5			29.9	21		3.3	5.69			114	14		6.4	22.0	28	3.3		7.72	96.0	17	5.4	18.5	33	2.8	9.17	89.7	18	5.0	17.3	36	2.6	9.81	76.5	21	5.3	14.8	42	2.7	11.50	73.9	22	5.2	14.3	43	2.6	11.90	63.8	25	5.3	12.3	50	2.7	13.80	60.2	27	5.0	11.6	53	2.6	14.62	49.3	33	4.1	9.5	65	2.1	17.86	46.1	35	3.9	8.9	70	2.0	19.07	44.4	36	3.7	8.6	72	1.9	19.83	37.4	43	3.1	7.2	86	1.6	23.56	29.8	54	2.5	5.8	108	1.3	29.56	24.8	65	2.1	4.8	129	1.1	35.47	19.2	84	1.6	3.7	167	0.8	45.89	18.0	89	1.5	3.5	179	0.8	49.00	16.5	97	1.4	3.2	195	0.7	53.33	18.9	83	1.6	3.6	166	0.8	46.61	CMGV 013/018	461	6	8.6		89.0	14	5.0		3.82	CMGV 012/018	15.9		99		1.4		3.1		198		0.7		55.36	13.9		113	1.2		2.7	226	0.6	63.22	18.6	84	2.7	3.6	169	1.4	47.19	CMGV 023/018	380		8		7.1		73.4		17		4.1	4.63	15.7	100	2.2	3.0	200	1.1	56.05	13.7	114	2.0	2.7	229	1.0	64.01	11.6	136	1.6	2.2	272	0.8	76.02	9.7	161	1.4	1.9	323	0.7	90.29	7.7	204	1.1	1.5	409	0.6	114.46	19.5	81	4.2	3.8	161	2.1	45.21	CMGV 033/018						309	9	5.8	59.8	21	3.3	5.69	14.4	110	3.1	2.8	219	1.6	61.32	12.1	130	2.6	2.3	260	1.3	72.83	9.0	174	1.9	1.7	348	1.0	97.45	7.6	207	1.6	1.5	413	0.8	115.74	6.2	251	1.3	1.2	503	0.7	140.81	5.0	311	1.1	1.0	622	0.6	174.26	37.8	74	1.4	7.3	166	0.8	46.61						CMGV 013/018	228	13	5.7	44.0	28	3.3	7.72	31.8	88	1.2	6.1	198	0.7	55.36	27.8	101	1.1	5.4	226	0.6	63.22	37.3	75		2.4		7.2		169		1.4		47.19	CMGV 023/018	192	15	4.8	37.1	33	2.8	9.17	31.4	90	2.0	6.1	200	1.1	56.05	27.5	102	1.7	5.3	229	1.0	64.01	23.2	121	1.5	4.5	272	0.8	76.02	19.5	144	1.2	3.8	323	0.7	90.29	15.4	183	1.0	3.0	409	0.6	114.46														
	58.1	28	2.8	11.2	55	1.5	15.14			48.4	33	2.4	9.4	66	1.2	18.17		40.8	39	2.0	7.9	79	1.0	21.58	37.4	43	1.8	7.2	86	0.9	23.51	35.1	46	1.7	6.8	92	0.9	25.1	32.5	49	1.6	6.3	99	0.8	27.08	27.1	59	1.3	5.2	119	0.7	32.49	230	7	9.7	44.5	14	5.0	3.82	CMGV 012/018	63C2 n ₁ =2800 [min ⁻¹]	350	8	4.3	67.6	18			2.5	5.03	CMGV 002/018	190	8			8.0	36.7		17	4.1			4.63	155		10	6.5			29.9	21		3.3	5.69			114	14		6.4	22.0			28	3.3		7.72	96.0	17	5.4		18.5	33	2.8	9.17	89.7	18	5.0	17.3	36	2.6	9.81	76.5	21	5.3	14.8	42	2.7	11.50	73.9	22	5.2	14.3	43	2.6	11.90	63.8	25	5.3	12.3	50	2.7	13.80	60.2	27	5.0	11.6	53	2.6	14.62	49.3	33	4.1	9.5	65	2.1	17.86	46.1	35	3.9	8.9	70	2.0	19.07	44.4	36	3.7	8.6	72	1.9	19.83	37.4	43	3.1	7.2	86	1.6	23.56	29.8	54	2.5	5.8	108	1.3	29.56	24.8	65	2.1	4.8	129	1.1	35.47	19.2	84	1.6	3.7	167	0.8	45.89	18.0	89	1.5	3.5	179	0.8	49.00	16.5	97	1.4	3.2	195	0.7	53.33	18.9	83	1.6	3.6	166	0.8	46.61	CMGV 013/018	461	6	8.6		89.0	14	5.0		3.82	CMGV 012/018	15.9		99		1.4		3.1		198		0.7		55.36		13.9		113	1.2		2.7	226		0.6	63.22	18.6	84	2.7	3.6	169	1.4	47.19	CMGV 023/018	380		8		7.1		73.4		17		4.1		4.63	15.7	100	2.2	3.0	200	1.1	56.05	13.7	114	2.0	2.7	229	1.0	64.01	11.6	136	1.6	2.2	272	0.8	76.02	9.7	161	1.4	1.9	323	0.7	90.29	7.7	204	1.1	1.5	409	0.6	114.46	19.5	81	4.2	3.8	161	2.1	45.21	CMGV 033/018							309	9	5.8	59.8	21	3.3	5.69	14.4	110	3.1	2.8	219	1.6	61.32	12.1	130	2.6	2.3	260	1.3	72.83	9.0	174	1.9	1.7	348	1.0	97.45	7.6	207	1.6	1.5	413	0.8	115.74	6.2	251	1.3	1.2	503	0.7	140.81	5.0	311	1.1	1.0	622	0.6	174.26	37.8	74	1.4	7.3	166	0.8	46.61							CMGV 013/018	228	13	5.7	44.0	28	3.3	7.72	31.8	88	1.2	6.1	198	0.7	55.36	27.8	101	1.1	5.4	226	0.6	63.22	37.3		75		2.4		7.2		169		1.4		47.19	CMGV 023/018	192	15	4.8	37.1	33	2.8	9.17	31.4	90	2.0	6.1	200	1.1	56.05	27.5	102	1.7	5.3	229	1.0	64.01	23.2	121	1.5	4.5	272	0.8	76.02	19.5	144	1.2	3.8	323	0.7	90.29	15.4	183	1.0	3.0	409	0.6	114.46												
	48.4	33	2.4	9.4	66	1.2	18.17			40.8	39	2.0	7.9	79	1.0	21.58		37.4	43	1.8	7.2	86	0.9	23.51	35.1	46	1.7	6.8	92	0.9	25.1	32.5	49	1.6	6.3	99	0.8	27.08	27.1	59	1.3	5.2	119	0.7	32.49	230	7	9.7	44.5	14	5.0	3.82	CMGV 012/018	63C2 n ₁ =2800 [min ⁻¹]	350	8	4.3	67.6	18			2.5	5.03	CMGV 002/018	190	8			8.0	36.7		17	4.1			4.63	155		10	6.5			29.9	21		3.3	5.69			114	14		6.4	22.0			28	3.3		7.72	96.0			17	5.4		18.5	33	2.8	9.17		89.7	18	5.0	17.3	36	2.6	9.81	76.5	21	5.3	14.8	42	2.7	11.50	73.9	22	5.2	14.3	43	2.6	11.90	63.8	25	5.3	12.3	50	2.7	13.80	60.2	27	5.0	11.6	53	2.6	14.62	49.3	33	4.1	9.5	65	2.1	17.86	46.1	35	3.9	8.9	70	2.0	19.07	44.4	36	3.7	8.6	72	1.9	19.83	37.4	43	3.1	7.2	86	1.6	23.56	29.8	54	2.5	5.8	108	1.3	29.56	24.8	65	2.1	4.8	129	1.1	35.47	19.2	84	1.6	3.7	167	0.8	45.89	18.0	89	1.5	3.5	179	0.8	49.00	16.5	97	1.4	3.2	195	0.7	53.33	18.9	83	1.6	3.6	166	0.8	46.61	CMGV 013/018	461	6	8.6		89.0	14	5.0		3.82	CMGV 012/018	15.9		99		1.4		3.1		198		0.7		55.36		13.9		113		1.2		2.7	226		0.6	63.22		18.6	84	2.7	3.6	169	1.4	47.19	CMGV 023/018	380		8		7.1		73.4		17		4.1		4.63		15.7	100	2.2	3.0	200	1.1	56.05	13.7	114	2.0	2.7	229	1.0	64.01	11.6	136	1.6	2.2	272	0.8	76.02	9.7	161	1.4	1.9	323	0.7	90.29	7.7	204	1.1	1.5	409	0.6	114.46	19.5	81	4.2	3.8	161	2.1	45.21	CMGV 033/018								309	9	5.8	59.8	21	3.3	5.69	14.4	110	3.1	2.8	219	1.6	61.32	12.1	130	2.6	2.3	260	1.3	72.83	9.0	174	1.9	1.7	348	1.0	97.45	7.6	207	1.6	1.5	413	0.8	115.74	6.2	251	1.3	1.2	503	0.7	140.81	5.0	311	1.1	1.0	622	0.6	174.26	37.8	74	1.4	7.3	166	0.8	46.61								CMGV 013/018	228	13	5.7	44.0	28	3.3	7.72	31.8	88	1.2	6.1	198	0.7	55.36	27.8	101	1.1	5.4	226	0.6	63.22		37.3		75		2.4		7.2		169		1.4		47.19	CMGV 023/018	192	15	4.8	37.1	33	2.8	9.17	31.4	90	2.0	6.1	200	1.1	56.05	27.5	102	1.7	5.3	229	1.0	64.01	23.2	121	1.5	4.5	272	0.8	76.02	19.5	144	1.2	3.8	323	0.7	90.29	15.4	183	1.0	3.0	409	0.6	114.46										
	40.8	39	2.0	7.9	79	1.0	21.58			37.4	43	1.8	7.2	86	0.9	23.51		35.1	46	1.7	6.8	92	0.9	25.1	32.5	49	1.6	6.3	99	0.8	27.08	27.1	59	1.3	5.2	119	0.7	32.49	230	7	9.7	44.5	14	5.0	3.82	CMGV 012/018	63C2 n ₁ =2800 [min ⁻¹]	350	8	4.3	67.6	18			2.5	5.03	CMGV 002/018	190	8			8.0	36.7		17	4.1			4.63	155		10	6.5			29.9	21		3.3	5.69			114	14		6.4	22.0			28	3.3		7.72	96.0			17	5.4		18.5	33			2.8	9.17		89.7	18	5.0	17.3		36	2.6	9.81	76.5	21	5.3	14.8	42	2.7	11.50	73.9	22	5.2	14.3	43	2.6	11.90	63.8	25	5.3	12.3	50	2.7	13.80	60.2	27	5.0	11.6	53	2.6	14.62	49.3	33	4.1	9.5	65	2.1	17.86	46.1	35	3.9	8.9	70	2.0	19.07	44.4	36	3.7	8.6	72	1.9	19.83	37.4	43	3.1	7.2	86	1.6	23.56	29.8	54	2.5	5.8	108	1.3	29.56	24.8	65	2.1	4.8	129	1.1	35.47	19.2	84	1.6	3.7	167	0.8	45.89	18.0	89	1.5	3.5	179	0.8	49.00	16.5	97	1.4	3.2	195	0.7	53.33	18.9	83	1.6	3.6	166	0.8	46.61	CMGV 013/018	461	6	8.6		89.0	14	5.0		3.82	CMGV 012/018	15.9		99		1.4		3.1		198		0.7		55.36		13.9		113		1.2		2.7		226		0.6	63.22		18.6	84		2.7	3.6	169	1.4	47.19	CMGV 023/018	380		8		7.1		73.4		17		4.1		4.63		15.7		100	2.2	3.0	200	1.1	56.05	13.7	114	2.0	2.7	229	1.0	64.01	11.6	136	1.6	2.2	272	0.8	76.02	9.7	161	1.4	1.9	323	0.7	90.29	7.7	204	1.1	1.5	409	0.6	114.46	19.5	81	4.2	3.8	161	2.1	45.21	CMGV 033/018									309	9	5.8	59.8	21	3.3	5.69	14.4	110	3.1	2.8	219	1.6	61.32	12.1	130	2.6	2.3	260	1.3	72.83	9.0	174	1.9	1.7	348	1.0	97.45	7.6	207	1.6	1.5	413	0.8	115.74	6.2	251	1.3	1.2	503	0.7	140.81	5.0	311	1.1	1.0	622	0.6	174.26	37.8	74	1.4	7.3	166	0.8	46.61									CMGV 013/018	228	13	5.7	44.0	28	3.3	7.72	31.8	88	1.2	6.1	198	0.7	55.36	27.8	101	1.1	5.4	226	0.6		63.22		37.3		75		2.4		7.2		169		1.4		47.19	CMGV 023/018	192	15	4.8	37.1	33	2.8	9.17	31.4	90	2.0	6.1	200	1.1	56.05	27.5	102	1.7	5.3	229	1.0	64.01	23.2	121	1.5	4.5	272	0.8	76.02	19.5	144	1.2	3.8	323	0.7	90.29	15.4	183	1.0	3.0	409	0.6	114.46								
	37.4	43	1.8	7.2	86	0.9	23.51			35.1	46	1.7	6.8	92	0.9	25.1		32.5	49	1.6	6.3	99	0.8	27.08	27.1	59	1.3	5.2	119	0.7	32.49	230	7	9.7	44.5	14	5.0	3.82	CMGV 012/018	63C2 n ₁ =2800 [min ⁻¹]	350	8	4.3	67.6	18			2.5	5.03	CMGV 002/018	190	8			8.0	36.7		17	4.1			4.63	155		10	6.5			29.9	21		3.3	5.69			114	14		6.4	22.0			28	3.3		7.72	96.0			17	5.4		18.5	33			2.8	9.17		89.7	18			5.0	17.3		36	2.6	9.81	76.5		21	5.3	14.8	42	2.7	11.50	73.9	22	5.2	14.3	43	2.6	11.90	63.8	25	5.3	12.3	50	2.7	13.80	60.2	27	5.0	11.6	53	2.6	14.62	49.3	33	4.1	9.5	65	2.1	17.86	46.1	35	3.9	8.9	70	2.0	19.07	44.4	36	3.7	8.6	72	1.9	19.83	37.4	43	3.1	7.2	86	1.6	23.56	29.8	54	2.5	5.8	108	1.3	29.56	24.8	65	2.1	4.8	129	1.1	35.47	19.2	84	1.6	3.7	167	0.8	45.89	18.0	89	1.5	3.5	179	0.8	49.00	16.5	97	1.4	3.2	195	0.7	53.33	18.9	83	1.6	3.6	166	0.8	46.61	CMGV 013/018	461	6	8.6		89.0	14	5.0		3.82	CMGV 012/018	15.9		99		1.4		3.1		198		0.7		55.36		13.9		113		1.2		2.7		226		0.6		63.22		18.6	84		2.7	3.6		169	1.4	47.19	CMGV 023/018	380		8		7.1		73.4		17		4.1		4.63		15.7		100		2.2	3.0	200	1.1	56.05	13.7	114	2.0	2.7	229	1.0	64.01	11.6	136	1.6	2.2	272	0.8	76.02	9.7	161	1.4	1.9	323	0.7	90.29	7.7	204	1.1	1.5	409	0.6	114.46	19.5	81	4.2	3.8	161	2.1	45.21	CMGV 033/018										309	9	5.8	59.8	21	3.3	5.69	14.4	110	3.1	2.8	219	1.6	61.32	12.1	130	2.6	2.3	260	1.3	72.83	9.0	174	1.9	1.7	348	1.0	97.45	7.6	207	1.6	1.5	413	0.8	115.74	6.2	251	1.3	1.2	503	0.7	140.81	5.0	311	1.1	1.0	622	0.6	174.26	37.8	74	1.4	7.3	166	0.8	46.61										CMGV 013/018	228	13	5.7	44.0	28	3.3	7.72	31.8	88	1.2	6.1	198	0.7	55.36	27.8	101	1.1	5.4	226		0.6		63.22		37.3		75		2.4		7.2		169		1.4		47.19	CMGV 023/018	192	15	4.8	37.1	33	2.8	9.17	31.4	90	2.0	6.1	200	1.1	56.05	27.5	102	1.7	5.3	229	1.0	64.01	23.2	121	1.5	4.5	272	0.8	76.02	19.5	144	1.2	3.8	323	0.7	90.29	15.4	183	1.0	3.0	409	0.6	114.46						
	35.1	46	1.7	6.8	92	0.9	25.1			32.5	49	1.6	6.3	99	0.8	27.08		27.1	59	1.3	5.2	119	0.7	32.49	230	7	9.7	44.5	14	5.0	3.82	CMGV 012/018	63C2 n ₁ =2800 [min ⁻¹]	350	8	4.3	67.6	18			2.5	5.03	CMGV 002/018	190	8			8.0	36.7		17	4.1			4.63	155		10	6.5			29.9	21		3.3	5.69			114	14		6.4	22.0			28	3.3		7.72	96.0			17	5.4		18.5	33			2.8	9.17		89.7	18			5.0	17.3		36	2.6			9.81	76.5		21	5.3	14.8	42		2.7	11.50	73.9	22	5.2	14.3	43	2.6	11.90	63.8	25	5.3	12.3	50	2.7	13.80	60.2	27	5.0	11.6	53	2.6	14.62	49.3	33	4.1	9.5	65	2.1	17.86	46.1	35	3.9	8.9	70	2.0	19.07	44.4	36	3.7	8.6	72	1.9	19.83	37.4	43	3.1	7.2	86	1.6	23.56	29.8	54	2.5	5.8	108	1.3	29.56	24.8	65	2.1	4.8	129	1.1	35.47	19.2	84	1.6	3.7	167	0.8	45.89	18.0	89	1.5	3.5	179	0.8	49.00	16.5	97	1.4	3.2	195	0.7	53.33	18.9	83	1.6	3.6	166	0.8	46.61	CMGV 013/018	461	6	8.6		89.0	14	5.0		3.82	CMGV 012/018	15.9		99		1.4		3.1		198		0.7		55.36		13.9		113		1.2		2.7		226		0.6		63.22		18.6		84		2.7	3.6		169	1.4		47.19	CMGV 023/018	380		8		7.1		73.4		17		4.1		4.63		15.7		100		2.2		3.0	200	1.1	56.05	13.7	114	2.0	2.7	229	1.0	64.01	11.6	136	1.6	2.2	272	0.8	76.02	9.7	161	1.4	1.9	323	0.7	90.29	7.7	204	1.1	1.5	409	0.6	114.46	19.5	81	4.2	3.8	161	2.1	45.21	CMGV 033/018											309	9	5.8	59.8	21	3.3	5.69	14.4	110	3.1	2.8	219	1.6	61.32	12.1	130	2.6	2.3	260	1.3	72.83	9.0	174	1.9	1.7	348	1.0	97.45	7.6	207	1.6	1.5	413	0.8	115.74	6.2	251	1.3	1.2	503	0.7	140.81	5.0	311	1.1	1.0	622	0.6	174.26	37.8	74	1.4	7.3	166	0.8	46.61											CMGV 013/018	228	13	5.7	44.0	28	3.3	7.72	31.8	88	1.2	6.1	198	0.7	55.36	27.8	101	1.1	5.4		226		0.6		63.22		37.3		75		2.4		7.2		169		1.4		47.19	CMGV 023/018	192	15	4.8	37.1	33	2.8	9.17	31.4	90	2.0	6.1	200	1.1	56.05	27.5	102	1.7	5.3	229	1.0	64.01	23.2	121	1.5	4.5	272	0.8	76.02	19.5	144	1.2	3.8	323	0.7	90.29	15.4	183	1.0	3.0	409	0.6	114.46				
	32.5	49	1.6	6.3	99	0.8	27.08			27.1	59	1.3	5.2	119	0.7	32.49		230	7	9.7	44.5	14	5.0	3.82	CMGV 012/018	63C2 n ₁ =2800 [min ⁻¹]	350	8	4.3	67.6	18			2.5	5.03	CMGV 002/018	190	8			8.0	36.7		17	4.1			4.63	155		10	6.5			29.9	21		3.3	5.69			114	14		6.4	22.0			28	3.3		7.72	96.0			17	5.4		18.5	33			2.8	9.17		89.7	18			5.0	17.3		36	2.6			9.81	76.5		21	5.3			14.8	42		2.7	11.50	73.9	22		5.2	14.3	43	2.6	11.90	63.8	25	5.3	12.3	50	2.7	13.80	60.2	27	5.0	11.6	53	2.6	14.62	49.3	33	4.1	9.5	65	2.1	17.86	46.1	35	3.9	8.9	70	2.0	19.07	44.4	36	3.7	8.6	72	1.9	19.83	37.4	43	3.1	7.2	86	1.6	23.56	29.8	54	2.5	5.8	108	1.3	29.56	24.8	65	2.1	4.8	129	1.1	35.47	19.2	84	1.6	3.7	167	0.8	45.89	18.0	89	1.5	3.5	179	0.8	49.00	16.5	97	1.4	3.2	195	0.7	53.33	18.9	83	1.6	3.6	166	0.8	46.61	CMGV 013/018	461	6	8.6		89.0	14	5.0		3.82	CMGV 012/018	15.9		99		1.4		3.1		198		0.7		55.36		13.9		113		1.2		2.7		226		0.6		63.22		18.6		84		2.7		3.6		169	1.4		47.19	CMGV 023/018		380		8		7.1		73.4		17		4.1		4.63		15.7		100		2.2		3.0		200	1.1	56.05	13.7	114	2.0	2.7	229	1.0	64.01	11.6	136	1.6	2.2	272	0.8	76.02	9.7	161	1.4	1.9	323	0.7	90.29	7.7	204	1.1	1.5	409	0.6	114.46	19.5	81	4.2	3.8	161	2.1	45.21	CMGV 033/018												309	9	5.8	59.8	21	3.3	5.69	14.4	110	3.1	2.8	219	1.6	61.32	12.1	130	2.6	2.3	260	1.3	72.83	9.0	174	1.9	1.7	348	1.0	97.45	7.6	207	1.6	1.5	413	0.8	115.74	6.2	251	1.3	1.2	503	0.7	140.81	5.0	311	1.1	1.0	622	0.6	174.26	37.8	74	1.4	7.3	166	0.8	46.61												CMGV 013/018	228	13	5.7	44.0	28	3.3	7.72	31.8	88	1.2	6.1	198	0.7	55.36	27.8	101	1.1		5.4		226		0.6		63.22		37.3		75		2.4		7.2		169		1.4		47.19	CMGV 023/018	192	15	4.8	37.1	33	2.8	9.17	31.4	90	2.0	6.1	200	1.1	56.05	27.5	102	1.7	5.3	229	1.0	64.01	23.2	121	1.5	4.5	272	0.8	76.02	19.5	144	1.2	3.8	323	0.7	90.29	15.4	183	1.0	3.0	409	0.6	114.46		
	27.1	59	1.3	5.2	119	0.7	32.49			230	7	9.7	44.5	14	5.0	3.82		CMGV 012/018	63C2 n ₁ =2800 [min ⁻¹]	350	8	4.3	67.6	18			2.5	5.03	CMGV 002/018	190	8			8.0	36.7		17	4.1			4.63	155		10	6.5			29.9	21		3.3	5.69			114	14		6.4	22.0			28	3.3		7.72	96.0			17	5.4		18.5	33			2.8	9.17		89.7	18			5.0	17.3		36	2.6			9.81	76.5		21	5.3			14.8	42		2.7	11.50			73.9	22		5.2	14.3	43	2.6		11.90	63.8	25	5.3	12.3	50	2.7	13.80	60.2	27	5.0	11.6	53	2.6	14.62	49.3	33	4.1	9.5	65	2.1	17.86	46.1	35	3.9	8.9	70	2.0	19.07	44.4	36	3.7	8.6	72	1.9	19.83	37.4	43	3.1	7.2	86	1.6	23.56	29.8	54	2.5	5.8	108	1.3	29.56	24.8	65	2.1	4.8	129	1.1	35.47	19.2	84	1.6	3.7	167	0.8	45.89	18.0	89	1.5	3.5	179	0.8	49.00	16.5	97	1.4	3.2	195	0.7	53.33	18.9	83	1.6	3.6	166	0.8	46.61	CMGV 013/018	461	6	8.6		89.0	14	5.0		3.82	CMGV 012/018	15.9		99		1.4		3.1		198		0.7		55.36		13.9		113		1.2		2.7		226		0.6		63.22		18.6		84		2.7		3.6		169		1.4		47.19	CMGV 023/018		380			8		7.1		73.4		17		4.1		4.63		15.7		100		2.2		3.0		200		1.1	56.05	13.7	114	2.0	2.7	229	1.0	64.01	11.6	136	1.6	2.2	272	0.8	76.02	9.7	161	1.4	1.9	323	0.7	90.29	7.7	204	1.1	1.5	409	0.6	114.46	19.5	81	4.2	3.8	161	2.1	45.21	CMGV 033/018													309	9	5.8	59.8	21	3.3	5.69	14.4	110	3.1	2.8	219	1.6	61.32	12.1	130	2.6	2.3	260	1.3	72.83	9.0	174	1.9	1.7	348	1.0	97.45	7.6	207	1.6	1.5	413	0.8	115.74	6.2	251	1.3	1.2	503	0.7	140.81	5.0	311	1.1	1.0	622	0.6	174.26	37.8	74	1.4	7.3	166	0.8	46.61													CMGV 013/018	228	13	5.7	44.0	28	3.3	7.72	31.8	88	1.2	6.1	198	0.7	55.36	27.8	101		1.1		5.4		226		0.6		63.22		37.3		75		2.4		7.2		169		1.4		47.19	CMGV 023/018	192	15	4.8	37.1	33	2.8	9.17	31.4	90	2.0	6.1	200	1.1	56.05	27.5	102	1.7	5.3	229	1.0	64.01	23.2	121	1.5	4.5	272	0.8	76.02	19.5	144	1.2	3.8	323	0.7	90.29	15.4	183	1.0	3.0	409	0.6	114.46
	230	7	9.7	44.5	14	5.0	3.82			CMGV 012/018	63C2 n ₁ =2800 [min ⁻¹]	350	8	4.3	67.6	18				2.5	5.03	CMGV 002/018																																																																																																																																																																																																																																																																																																																																																																																																																																																																							
	190	8	8.0	36.7	17	4.1	4.63					155	10	6.5	29.9	21				3.3	5.69		114	14			6.4	22.0		28	3.3			7.72	96.0		17	5.4			18.5	33		2.8	9.17			89.7	18		5.0	17.3			36	2.6		9.81	76.5			21	5.3		14.8	42			2.7	11.50		73.9	22			5.2	14.3		43	2.6			11.90	63.8		25	5.3			12.3	50		2.7	13.80			60.2	27		5.0	11.6			53	2.6		14.62	49.3	33	4.1		9.5	65	2.1	17.86	46.1	35	3.9	8.9	70	2.0	19.07	44.4	36	3.7	8.6	72	1.9	19.83	37.4	43	3.1	7.2	86	1.6	23.56	29.8	54	2.5	5.8	108	1.3	29.56	24.8	65	2.1	4.8	129	1.1	35.47	19.2	84	1.6	3.7	167	0.8	45.89	18.0	89	1.5	3.5	179	0.8	49.00	16.5	97	1.4	3.2	195	0.7	53.33	18.9	83	1.6	3.6	166	0.8	46.61	CMGV 013/018	461	6	8.6	89.0	14	5.0	3.82	CMGV 012/018	15.9	99	1.4	3.1	198	0.7	55.36	13.9	113		1.2	2.7	226		0.6	63.22	18.6		84		2.7		3.6		169		1.4		47.19		CMGV 023/018		380		8		7.1		73.4		17		4.1		4.63		15.7		100		2.2		3.0		200		1.1		56.05		13.7			114			2.0		2.7		229		1.0		64.01		11.6		136		1.6		2.2		272		0.8		76.02	9.7	161	1.4	1.9	323	0.7	90.29	7.7	204	1.1	1.5	409	0.6	114.46	19.5	81	4.2	3.8	161	2.1	45.21	CMGV 033/018	309	9	5.8	59.8	21	3.3	5.69	14.4	110	3.1	2.8	219	1.6	61.32														12.1	130	2.6	2.3	260	1.3	72.83	9.0	174	1.9	1.7	348	1.0	97.45	7.6	207	1.6	1.5	413	0.8	115.74	6.2	251	1.3	1.2	503	0.7	140.81	5.0	311	1.1	1.0	622	0.6	174.26	37.8	74	1.4	7.3	166	0.8	46.61	CMGV 013/018	228	13	5.7	44.0	28	3.3	7.72	31.8	88	1.2	6.1	198	0.7														55.36	27.8	101	1.1	5.4	226	0.6	63.22	37.3	75	2.4	7.2	169	1.4	47.19	CMGV 023/018		192		15		4.8		37.1		33		2.8		9.17		31.4		90		2.0		6.1		200		1.1	56.05	27.5	102	1.7	5.3	229	1.0	64.01	23.2	121	1.5	4.5	272	0.8	76.02	19.5	144	1.2	3.8	323	0.7	90.29	15.4	183	1.0	3.0	409	0.6	114.46												
	155	10	6.5	29.9	21	3.3	5.69					114	14	6.4	22.0	28				3.3	7.72		96.0	17			5.4	18.5		33	2.8			9.17	89.7		18	5.0			17.3	36		2.6	9.81			76.5	21		5.3	14.8			42	2.7		11.50	73.9			22	5.2		14.3	43			2.6	11.90		63.8	25			5.3	12.3		50	2.7			13.80	60.2		27	5.0			11.6	53		2.6	14.62			49.3	33		4.1	9.5			65	2.1		17.86	46.1	35	3.9		8.9	70	2.0	19.07	44.4	36	3.7	8.6	72	1.9	19.83	37.4	43	3.1	7.2	86	1.6	23.56	29.8	54	2.5	5.8	108	1.3	29.56	24.8	65	2.1	4.8	129	1.1	35.47	19.2	84	1.6	3.7	167	0.8	45.89	18.0	89	1.5	3.5	179	0.8	49.00	16.5	97	1.4	3.2	195	0.7	53.33	18.9	83	1.6	3.6	166	0.8	46.61	CMGV 013/018	461	6	8.6	89.0	14	5.0		3.82	CMGV 012/018	15.9	99	1.4	3.1	198		0.7	55.36	13.9	113	1.2	2.7	226	0.6	63.22		18.6	84	2.7		3.6	169	1.4		47.19		CMGV 023/018		380		8		7.1		73.4				17		4.1		4.63		15.7		100		2.2		3.0		200		1.1		56.05		13.7		114		2.0		2.7		229			1.0			64.01		11.6		136		1.6		2.2		272		0.8		76.02		9.7		161		1.4		1.9	323	0.7	90.29	7.7	204	1.1	1.5	409	0.6	114.46	19.5	81	4.2	3.8	161	2.1	45.21	CMGV 033/018	309	9	5.8		59.8	21	3.3	5.69	14.4	110	3.1	2.8	219	1.6	61.32	12.1	130	2.6														2.3	260	1.3	72.83	9.0	174	1.9	1.7	348	1.0	97.45	7.6	207	1.6	1.5	413	0.8	115.74	6.2	251	1.3	1.2	503	0.7	140.81	5.0	311	1.1	1.0	622	0.6	174.26	37.8	74	1.4	7.3	166	0.8	46.61	CMGV 013/018	228	13		5.7	44.0	28	3.3	7.72	31.8	88	1.2	6.1	198	0.7	55.36	27.8														101	1.1	5.4	226	0.6	63.22	37.3	75	2.4	7.2	169	1.4	47.19	CMGV 023/018	192			15		4.8		37.1		33		2.8		9.17		31.4		90		2.0		6.1		200		1.1		56.05	27.5	102	1.7	5.3	229	1.0	64.01	23.2	121	1.5	4.5	272	0.8	76.02	19.5	144	1.2	3.8	323	0.7	90.29	15.4	183	1.0	3.0	409	0.6	114.46													
	114	14	6.4	22.0	28	3.3	7.72					96.0	17	5.4	18.5	33				2.8	9.17		89.7	18			5.0	17.3		36	2.6			9.81	76.5		21	5.3			14.8	42		2.7	11.50			73.9	22		5.2	14.3			43	2.6		11.90	63.8			25	5.3		12.3	50			2.7	13.80		60.2	27			5.0	11.6		53	2.6			14.62	49.3		33	4.1			9.5	65		2.1	17.86			46.1	35		3.9	8.9			70	2.0		19.07	44.4	36	3.7		8.6	72	1.9	19.83	37.4	43	3.1	7.2	86	1.6	23.56	29.8	54	2.5	5.8	108	1.3	29.56	24.8	65	2.1	4.8	129	1.1	35.47	19.2	84	1.6	3.7	167	0.8	45.89	18.0	89	1.5	3.5	179	0.8	49.00	16.5	97	1.4	3.2	195	0.7	53.33	18.9	83	1.6	3.6	166	0.8	46.61	CMGV 013/018	461	6	8.6	89.0	14	5.0		3.82	CMGV 012/018	15.9	99	1.4	3.1		198		0.7	55.36	13.9	113	1.2		2.7	226	0.6	63.22	18.6	84	2.7	3.6	169		1.4	47.19	CMGV 023/018		380	8	7.1		73.4				17		4.1		4.63		15.7				100		2.2		3.0		200		1.1		56.05		13.7		114		2.0		2.7		229		1.0		64.01		11.6		136			1.6			2.2		272		0.8		76.02		9.7		161		1.4		1.9		323		0.7		90.29		7.7	204	1.1	1.5	409	0.6	114.46	19.5	81	4.2	3.8	161	2.1	45.21	CMGV 033/018	309	9	5.8		59.8	21	3.3		5.69	14.4	110	3.1	2.8	219	1.6	61.32	12.1	130	2.6	2.3	260	1.3														72.83	9.0	174	1.9	1.7	348	1.0	97.45	7.6	207	1.6	1.5	413	0.8	115.74	6.2	251	1.3	1.2	503	0.7	140.81	5.0	311	1.1	1.0	622	0.6	174.26	37.8	74	1.4	7.3	166	0.8	46.61	CMGV 013/018	228	13		5.7	44.0		28	3.3	7.72	31.8	88	1.2	6.1	198	0.7	55.36	27.8	101	1.1														5.4	226	0.6	63.22	37.3	75	2.4	7.2	169	1.4	47.19	CMGV 023/018	192		15			4.8		37.1		33		2.8		9.17		31.4		90		2.0		6.1		200		1.1		56.05		27.5	102	1.7	5.3	229	1.0	64.01	23.2	121	1.5	4.5	272	0.8	76.02	19.5	144	1.2	3.8	323	0.7	90.29	15.4	183	1.0	3.0	409	0.6	114.46														
	96.0	17	5.4	18.5	33	2.8	9.17					89.7	18	5.0	17.3	36				2.6	9.81		76.5	21			5.3	14.8		42	2.7			11.50	73.9		22	5.2			14.3	43		2.6	11.90			63.8	25		5.3	12.3			50	2.7		13.80	60.2			27	5.0		11.6	53			2.6	14.62		49.3	33			4.1	9.5		65	2.1			17.86	46.1		35	3.9			8.9	70		2.0	19.07			44.4	36		3.7	8.6			72	1.9		19.83	37.4	43	3.1		7.2	86	1.6	23.56	29.8	54	2.5	5.8	108	1.3	29.56	24.8	65	2.1	4.8	129	1.1	35.47	19.2	84	1.6	3.7	167	0.8	45.89	18.0	89	1.5	3.5	179	0.8	49.00	16.5	97	1.4	3.2	195	0.7	53.33	18.9	83	1.6	3.6	166	0.8	46.61	CMGV 013/018	461	6	8.6	89.0	14	5.0		3.82	CMGV 012/018	15.9	99	1.4	3.1		198		0.7	55.36	13.9	113		1.2		2.7	226	0.6	63.22	18.6		84	2.7	3.6	169	1.4	47.19	CMGV 023/018	380	8		7.1	73.4			17	4.1	4.63		15.7				100		2.2		3.0		200				1.1		56.05		13.7		114		2.0		2.7		229		1.0		64.01		11.6		136		1.6		2.2		272		0.8			76.02			9.7		161		1.4		1.9		323		0.7		90.29		7.7		204		1.1		1.5		409	0.6	114.46	19.5	81	4.2	3.8	161	2.1	45.21	CMGV 033/018	309	9	5.8		59.8	21	3.3		5.69	14.4	110		3.1	2.8	219	1.6	61.32	12.1	130	2.6	2.3	260	1.3	72.83	9.0	174														1.9	1.7	348	1.0	97.45	7.6	207	1.6	1.5	413	0.8	115.74	6.2	251	1.3	1.2	503	0.7	140.81	5.0	311	1.1	1.0	622	0.6	174.26	37.8	74	1.4	7.3	166	0.8	46.61	CMGV 013/018	228	13		5.7	44.0		28	3.3		7.72	31.8	88	1.2	6.1	198	0.7	55.36	27.8	101	1.1	5.4	226														0.6	63.22	37.3	75	2.4	7.2	169	1.4	47.19	CMGV 023/018	192		15		4.8			37.1		33		2.8		9.17		31.4		90		2.0		6.1		200		1.1		56.05		27.5		102	1.7	5.3	229	1.0	64.01	23.2	121	1.5	4.5	272	0.8	76.02	19.5	144	1.2	3.8	323	0.7	90.29	15.4	183	1.0	3.0	409	0.6	114.46															
89.7	18	5.0	17.3	36	2.6	9.81	76.5	21	5.3			14.8	42	2.7	11.50	73.9	22			5.2	14.3		43	2.6			11.90	63.8		25	5.3			12.3	50		2.7	13.80			60.2	27		5.0	11.6			53	2.6		14.62	49.3			33	4.1		9.5	65			2.1	17.86		46.1	35			3.9	8.9		70	2.0			19.07	44.4		36	3.7			8.6	72		1.9	19.83			37.4	43		3.1	7.2			86	1.6		23.56	29.8			54	2.5		5.8	108	1.3	29.56		24.8	65	2.1	4.8	129	1.1	35.47	19.2	84	1.6	3.7	167	0.8	45.89	18.0	89	1.5	3.5	179	0.8	49.00	16.5	97	1.4	3.2	195	0.7	53.33	18.9	83	1.6	3.6	166	0.8	46.61	CMGV 013/018	461	6	8.6	89.0	14	5.0	3.82	CMGV 012/018	15.9	99		1.4	3.1	198	0.7	55.36	13.9		113		1.2	2.7	226	0.6		63.22		18.6	84	2.7	3.6		169		1.4	47.19	CMGV 023/018	380	8		7.1	73.4	17	4.1	4.63	15.7		100	2.2		3.0	200			1.1	56.05	13.7		114				2.0		2.7		229		1.0				64.01		11.6		136		1.6		2.2		272		0.8		76.02		9.7		161		1.4		1.9		323		0.7		90.29			7.7			204		1.1		1.5		409		0.6		114.46		19.5		81		4.2		3.8		161		2.1	45.21	CMGV 033/018	309	9	5.8	59.8	21	3.3	5.69		14.4	110	3.1		2.8	219	1.6		61.32	12.1	130		2.6	2.3	260	1.3	72.83	9.0	174	1.9	1.7	348	1.0	97.45	7.6	207														1.6	1.5	413	0.8	115.74	6.2	251	1.3	1.2	503	0.7	140.81	5.0	311	1.1	1.0	622	0.6	174.26	37.8	74	1.4	7.3	166	0.8	46.61	CMGV 013/018	228	13	5.7	44.0	28	3.3		7.72	31.8		88	1.2		6.1	198		0.7	55.36	27.8	101	1.1	5.4	226	0.6	63.22	37.3	75	2.4	7.2														169	1.4	47.19	CMGV 023/018	192	15	4.8	37.1	33		2.8		9.17		31.4			90		2.0		6.1		200		1.1		56.05		27.5		102		1.7		5.3		229		1.0		64.01	23.2	121	1.5	4.5	272	0.8	76.02	19.5	144	1.2	3.8	323	0.7	90.29	15.4	183	1.0	3.0	409	0.6	114.46																				
76.5	21	5.3	14.8	42	2.7	11.50	73.9	22	5.2			14.3	43	2.6	11.90	63.8	25			5.3	12.3		50	2.7			13.80	60.2		27	5.0			11.6	53		2.6	14.62			49.3	33		4.1	9.5			65	2.1		17.86	46.1			35	3.9		8.9	70			2.0	19.07		44.4	36			3.7	8.6		72	1.9			19.83	37.4		43	3.1			7.2	86		1.6	23.56			29.8	54		2.5	5.8			108	1.3		29.56	24.8	65	2.1	4.8	129		1.1	35.47	19.2	84	1.6	3.7	167	0.8	45.89	18.0	89	1.5	3.5	179	0.8	49.00	16.5	97	1.4	3.2	195	0.7	53.33	18.9	83	1.6	3.6	166	0.8	46.61	CMGV 013/018	461	6	8.6	89.0	14	5.0	3.82	CMGV 012/018	15.9		99	1.4	3.1	198	0.7	55.36	13.9		113	1.2		2.7	226	0.6	63.22	18.6	84		2.7		3.6	169	1.4	47.19		CMGV 023/018		380	8	7.1	73.4		17		4.1	4.63		15.7	100		2.2	3.0	200	1.1	56.05	13.7		114	2.0		2.7	229			1.0	64.01	11.6		136				1.6		2.2		272		0.8				76.02		9.7		161		1.4		1.9		323		0.7		90.29		7.7		204		1.1		1.5		409	0.6	114.46		19.5			81		4.2	3.8		161		2.1		45.21		CMGV 033/018		309		9		5.8		59.8		21		3.3	5.69	14.4	110		3.1	2.8	219	1.6	61.32	12.1	130		2.6	2.3	260		1.3	72.83	9.0		174	1.9	1.7		348	1.0	97.45	7.6	207	1.6	1.5	413	0.8	115.74	6.2	251	1.3	1.2													503	0.7	140.81	5.0	311	1.1	1.0	622	0.6	174.26	37.8	74	1.4	7.3	166	0.8	46.61	CMGV 013/018	228	13	5.7	44.0	28	3.3	7.72	31.8	88		1.2	6.1	198	0.7	55.36	27.8		101	1.1		5.4	226		0.6	63.22		37.3	75	2.4	7.2	169	1.4	47.19	CMGV 023/018	192	15	4.8	37.1	33	2.8													9.17	31.4	90		2.0	6.1	200	1.1	56.05		27.5		102		1.7		5.3	229		1.0		64.01		23.2		121		1.5		4.5		272		0.8		76.02		19.5		144		1.2	3.8	323	0.7	90.29	15.4	183	1.0	3.0	409	0.6	114.46																														
73.9	22	5.2	14.3	43	2.6	11.90	63.8	25	5.3			12.3	50	2.7	13.80	60.2	27			5.0	11.6		53	2.6			14.62	49.3		33	4.1			9.5	65		2.1	17.86			46.1	35		3.9	8.9			70	2.0		19.07	44.4			36	3.7		8.6	72			1.9	19.83		37.4	43			3.1	7.2		86	1.6			23.56	29.8		54	2.5			5.8	108		1.3	29.56			24.8	65		2.1	4.8	129	1.1	35.47	19.2		84	1.6	3.7	167	0.8	45.89	18.0	89	1.5	3.5	179	0.8	49.00	16.5	97	1.4	3.2	195	0.7	53.33	18.9	83	1.6	3.6	166	0.8	46.61	CMGV 013/018	461	6	8.6	89.0	14	5.0	3.82	CMGV 012/018	15.9		99	1.4	3.1	198	0.7	55.36	13.9		113		1.2	2.7	226	0.6	63.22	18.6	84		2.7	3.6		169	1.4	47.19	CMGV 023/018	380	8		7.1		73.4	17	4.1	4.63				15.7	100	2.2	3.0		200		1.1	56.05		13.7	114		2.0	2.7	229	1.0	64.01	11.6		136	1.6		2.2	272			0.8	76.02	9.7		161				1.4		1.9		323		0.7				90.29		7.7		204		1.1		1.5		409		0.6		114.46		19.5		81		4.2	3.8	161		2.1	45.21	CMGV 033/018		309		9	5.8		59.8	21		3.3		5.69		14.4				110		3.1		2.8		219		1.6	61.32	12.1	130	2.6	2.3		260	1.3	72.83	9.0	174	1.9	1.7		348	1.0	97.45		7.6	207	1.6		1.5	413	0.8		115.74	6.2	251	1.3	1.2	503	0.7	140.81	5.0	311	1.1	1.0	622	0.6												174.26	37.8	74	1.4	7.3	166	0.8	46.61	CMGV 013/018	228	13	5.7	44.0	28	3.3	7.72	31.8	88		1.2	6.1	198	0.7	55.36	27.8	101	1.1	5.4		226	0.6	63.22	37.3	75	2.4		7.2	169		1.4	47.19		CMGV 023/018	192		15	4.8	37.1	33	2.8	9.17	31.4		90	2.0	6.1	200	1.1	56.05	27.5												102	1.7	5.3		229	1.0	64.01	23.2	121		1.5		4.5		272		0.8	76.02	19.5	144		1.2		3.8		323		0.7		90.29		15.4		183		1.0		3.0		409		0.6	114.46																																								
63.8	25	5.3	12.3	50	2.7	13.80	60.2	27	5.0			11.6	53	2.6	14.62	49.3	33			4.1	9.5		65	2.1			17.86	46.1		35	3.9			8.9	70		2.0	19.07			44.4	36		3.7	8.6			72	1.9		19.83	37.4			43	3.1		7.2	86			1.6	23.56		29.8	54			2.5	5.8		108	1.3			29.56	24.8		65	2.1			4.8	129		1.1	35.47	19.2	84	1.6	3.7		167	0.8	45.89	18.0	89	1.5	3.5	179	0.8	49.00	16.5	97	1.4	3.2	195	0.7	53.33	18.9	83	1.6	3.6	166	0.8	46.61	CMGV 013/018	461	6	8.6	89.0	14	5.0	3.82	CMGV 012/018	15.9		99	1.4	3.1	198	0.7	55.36	13.9		113		1.2	2.7	226	0.6	63.22	18.6	84		2.7		3.6	169	1.4	47.19	CMGV 023/018	380	8		7.1	73.4		17	4.1	4.63		15.7	100		2.2		3.0	200	1.1	56.05				13.7	114	2.0	2.7		229		1.0	64.01		11.6	136		1.6	2.2	272	0.8	76.02	9.7		161	1.4		1.9	323			0.7	90.29	7.7		204				1.1		1.5		409		0.6				114.46		19.5		81		4.2		3.8		161		2.1		45.21		CMGV 033/018	309	9		5.8	59.8	21		3.3	5.69		14.4	110		3.1	2.8		219	1.6		61.32		12.1		130				2.6		2.3		260		1.3	72.83	9.0	174	1.9	1.7	348	1.0		97.45	7.6	207	1.6	1.5	413	0.8		115.74	6.2	251		1.3	1.2	503		0.7	140.81	5.0		311	1.1	1.0	622	0.6	174.26	37.8	74	1.4	7.3	166	0.8	46.61	CMGV 013/018											228	13	5.7	44.0	28	3.3	7.72	31.8	88		1.2	6.1	198	0.7	55.36	27.8	101	1.1	5.4		226	0.6	63.22	37.3	75	2.4	7.2	169	1.4		47.19	CMGV 023/018	192	15	4.8	37.1		33	2.8		9.17	31.4			90		2.0	6.1	200	1.1	56.05	27.5	102		1.7	5.3	229	1.0	64.01	23.2	121	1.5											4.5	272	0.8		76.02	19.5	144	1.2	3.8		323		0.7		90.29		15.4	183	1.0	3.0	409	0.6		114.46																																																											
60.2	27	5.0	11.6	53	2.6	14.62	49.3	33	4.1			9.5	65	2.1	17.86	46.1	35			3.9	8.9		70	2.0			19.07	44.4		36	3.7			8.6	72		1.9	19.83			37.4	43		3.1	7.2			86	1.6		23.56	29.8			54	2.5		5.8	108			1.3	29.56		24.8	65			2.1	4.8		129	1.1			35.47	19.2		84	1.6	3.7	167	0.8	45.89		18.0	89	1.5	3.5	179	0.8	49.00	16.5	97	1.4	3.2	195	0.7	53.33	18.9	83	1.6	3.6	166	0.8	46.61	CMGV 013/018	461	6	8.6	89.0	14	5.0	3.82	CMGV 012/018	15.9		99	1.4	3.1	198	0.7	55.36	13.9		113		1.2	2.7	226	0.6	63.22	18.6	84		2.7		3.6	169	1.4	47.19	CMGV 023/018	380	8		7.1		73.4	17	4.1	4.63		15.7	100		2.2	3.0		200	1.1	56.05		13.7	114		2.0		2.7	229	1.0	64.01				11.6	136	1.6	2.2		272		0.8	76.02		9.7	161		1.4	1.9	323	0.7	90.29	7.7		204	1.1		1.5	409			0.6	114.46	19.5		81				4.2		3.8		161		2.1				45.21		CMGV 033/018		309		9		5.8		59.8		21	3.3	5.69			14.4	110		3.1	2.8	219	1.6	61.32	12.1		130	2.6		2.3	260		1.3	72.83		9.0		174		1.9				1.7		348		1.0	97.45	7.6	207	1.6	1.5	413	0.8	115.74	6.2		251	1.3	1.2	503	0.7	140.81	5.0		311	1.1	1.0		622	0.6	174.26		37.8	74	1.4		7.3	166	0.8	46.61	CMGV 013/018	228	13	5.7	44.0	28	3.3	7.72	31.8											88	1.2	6.1	198	0.7	55.36	27.8	101	1.1	5.4		226	0.6	63.22	37.3	75	2.4	7.2	169	1.4		47.19	CMGV 023/018	192	15	4.8	37.1	33	2.8	9.17		31.4		90	2.0	6.1	200		1.1	56.05		27.5	102			1.7		5.3	229	1.0	64.01	23.2	121	1.5		4.5	272	0.8	76.02	19.5	144	1.2	3.8	323										0.7	90.29	15.4		183	1.0	3.0	409	0.6		114.46																																																																								
49.3	33	4.1	9.5	65	2.1	17.86	46.1	35	3.9			8.9	70	2.0	19.07	44.4	36			3.7	8.6		72	1.9			19.83	37.4		43	3.1			7.2	86		1.6	23.56			29.8	54		2.5	5.8			108	1.3		29.56	24.8			65	2.1		4.8	129			1.1	35.47		19.2	84			1.6	3.7		167	0.8	45.89	18.0	89	1.5		3.5	179	0.8	49.00	16.5	97	1.4	3.2	195	0.7	53.33	18.9	83	1.6	3.6	166	0.8	46.61	CMGV 013/018	461	6	8.6	89.0	14	5.0	3.82	CMGV 012/018	15.9		99	1.4	3.1	198	0.7	55.36	13.9		113		1.2	2.7	226	0.6	63.22	18.6	84		2.7		3.6	169	1.4	47.19	CMGV 023/018	380	8		7.1		73.4	17	4.1	4.63		15.7	100		2.2		3.0	200	1.1	56.05		13.7	114		2.0	2.7		229	1.0	64.01		11.6	136		1.6		2.2	272	0.8	76.02				9.7	161	1.4	1.9		323		0.7	90.29		7.7	204		1.1	1.5	409	0.6	114.46	19.5		81	4.2		3.8	161			2.1	45.21	CMGV 033/018		309				9		5.8		59.8		21				3.3				5.69		14.4		110	3.1	2.8		219	1.6	61.32			12.1	130	2.6	2.3	260	1.3	72.83	9.0	174		1.9	1.7		348	1.0		97.45	7.6		207		1.6		1.5				413		0.8	115.74	6.2	251	1.3	1.2	503	0.7	140.81	5.0	311	1.1		1.0	622	0.6	174.26	37.8	74	1.4		7.3	166	0.8		46.61	CMGV 013/018	228		13	5.7	44.0		28	3.3	7.72	31.8		88	1.2	6.1	198	0.7	55.36	27.8	101										1.1	5.4	226	0.6	63.22	37.3	75	2.4	7.2	169	1.4		47.19	CMGV 023/018	192	15	4.8	37.1	33	2.8	9.17		31.4		90	2.0	6.1	200	1.1	56.05	27.5		102		1.7	5.3	229	1.0		64.01	23.2		121	1.5			4.5		272	0.8	76.02	19.5	144	1.2	3.8		323	0.7	90.29	15.4	183	1.0	3.0	409	0.6	114.46																																																																																											
46.1	35	3.9	8.9	70	2.0	19.07	44.4	36	3.7			8.6	72	1.9	19.83	37.4	43			3.1	7.2		86	1.6			23.56	29.8		54	2.5			5.8	108		1.3	29.56			24.8	65		2.1	4.8			129	1.1		35.47	19.2			84	1.6		3.7	167			0.8	45.89		18.0	89	1.5	3.5	179	0.8		49.00	16.5	97	1.4	3.2	195	0.7	53.33	18.9	83	1.6	3.6	166	0.8	46.61	CMGV 013/018	461	6	8.6	89.0	14	5.0	3.82	CMGV 012/018	15.9		99	1.4	3.1	198	0.7	55.36	13.9		113		1.2	2.7	226	0.6	63.22	18.6	84		2.7		3.6	169	1.4	47.19	CMGV 023/018	380	8		7.1		73.4	17	4.1	4.63		15.7	100		2.2		3.0	200	1.1	56.05		13.7	114		2.0		2.7	229	1.0	64.01		11.6	136		1.6	2.2		272	0.8	76.02		9.7	161		1.4		1.9	323	0.7	90.29				7.7	204	1.1	1.5		409		0.6	114.46		19.5	81		4.2	3.8	161	2.1	45.21	CMGV 033/018		309	9		5.8	59.8			21	3.3			5.69				14.4		110		3.1		2.8				219				1.6	61.32	12.1		130	2.6	2.3		260	1.3	72.83	9.0		174	1.9	1.7	348	1.0	97.45	7.6	207	1.6		1.5	413		0.8	115.74		6.2	251		1.3		1.2		503				0.7	140.81	5.0	311	1.1	1.0	622	0.6	174.26	37.8	74	1.4	7.3	166		0.8	46.61	CMGV 013/018	228	13	5.7	44.0		28	3.3	7.72		31.8		88		1.2	6.1	198		0.7	55.36	27.8	101		1.1	5.4	226	0.6	63.22	37.3	75	2.4									7.2	169	1.4	47.19	CMGV 023/018	192	15	4.8	37.1	33	2.8	9.17		31.4		90	2.0	6.1	200	1.1	56.05	27.5		102		1.7	5.3	229	1.0	64.01	23.2	121		1.5		4.5	272	0.8	76.02		19.5	144		1.2	3.8			323		0.7	90.29	15.4	183	1.0	3.0	409		0.6	114.46																																																																																																			
44.4	36	3.7	8.6	72	1.9	19.83	37.4	43	3.1			7.2	86	1.6	23.56	29.8	54			2.5	5.8		108	1.3			29.56	24.8		65	2.1			4.8	129		1.1	35.47			19.2	84		1.6	3.7			167	0.8		45.89	18.0			89	1.5		3.5	179	0.8	49.00	16.5	97		1.4	3.2	195	0.7	53.33	18.9	83	1.6	3.6	166	0.8	46.61	CMGV 013/018	461	6	8.6	89.0	14	5.0	3.82	CMGV 012/018	15.9		99	1.4	3.1	198	0.7	55.36	13.9		113		1.2	2.7	226	0.6	63.22	18.6	84		2.7		3.6	169	1.4	47.19	CMGV 023/018	380	8		7.1		73.4	17	4.1	4.63		15.7	100		2.2		3.0	200	1.1	56.05		13.7	114		2.0		2.7	229	1.0	64.01		11.6	136		1.6		2.2	272	0.8	76.02		9.7	161		1.4	1.9		323	0.7	90.29		7.7	204		1.1		1.5	409	0.6	114.46				19.5	81	4.2	3.8		161		2.1	45.21		CMGV 033/018	309		9	5.8	59.8	21	3.3			5.69	14.4		110	3.1			2.8	219			1.6				61.32		12.1		130		2.6				2.3	260			1.3	72.83	9.0		174	1.9	1.7	348	1.0	97.45	7.6	207		1.6	1.5	413	0.8	115.74	6.2	251	1.3	1.2		503	0.7		140.81	5.0		311	1.1		1.0		622		0.6			174.26	37.8	74	1.4	7.3	166	0.8	46.61	CMGV 013/018	228	13	5.7	44.0	28	3.3		7.72	31.8		88	1.2	6.1	198		0.7	55.36	27.8		101		1.1		5.4	226	0.6		63.22	37.3	75	2.4		7.2	169	1.4	47.19	CMGV 023/018	192	15	4.8								37.1	33	2.8	9.17	31.4		90	2.0	6.1	200	1.1	56.05	27.5		102		1.7	5.3	229	1.0	64.01	23.2	121		1.5		4.5	272	0.8	76.02	19.5	144	1.2		3.8		323	0.7	90.29	15.4		183	1.0		3.0	409			0.6		114.46																																																																																																												
37.4	43	3.1	7.2	86	1.6	23.56	29.8	54	2.5			5.8	108	1.3	29.56	24.8	65			2.1	4.8		129	1.1			35.47	19.2		84	1.6			3.7	167		0.8	45.89			18.0	89		1.5	3.5			179	0.8		49.00	16.5	97	1.4	3.2	195		0.7	53.33	18.9	83	1.6	3.6	166	0.8	46.61	CMGV 013/018	461	6	8.6	89.0	14	5.0	3.82	CMGV 012/018	15.9		99	1.4	3.1	198	0.7	55.36	13.9		113		1.2	2.7	226	0.6	63.22	18.6	84		2.7		3.6	169	1.4	47.19	CMGV 023/018	380	8		7.1		73.4	17	4.1	4.63		15.7	100		2.2		3.0	200	1.1	56.05		13.7	114		2.0		2.7	229	1.0	64.01		11.6	136		1.6		2.2	272	0.8	76.02		9.7	161		1.4		1.9	323	0.7	90.29		7.7	204		1.1	1.5		409	0.6	114.46		19.5	81		4.2		3.8	161	2.1	45.21				CMGV 033/018	309	9	5.8		59.8		21	3.3			5.69		14.4	110	3.1	2.8	219			1.6	61.32		12.1	130			2.6	2.3			260				1.3		72.83		9.0		174	1.9			1.7	348			1.0	97.45	7.6	207	1.6	1.5	413	0.8	115.74	6.2	251	1.3		1.2	503	0.7	140.81	5.0	311	1.1	1.0	622		0.6	174.26		37.8	74		1.4	7.3		166		0.8		46.61	CMGV 013/018		228	13	5.7	44.0	28	3.3	7.72	31.8		88	1.2	6.1	198	0.7	55.36		27.8	101		1.1	5.4	226	0.6		63.22	37.3	75		2.4		7.2		169	1.4	47.19		CMGV 023/018	192	15	4.8		37.1	33	2.8	9.17		31.4	90	2.0							6.1	200	1.1	56.05	27.5	102		1.7	5.3	229	1.0	64.01	23.2	121		1.5		4.5	272	0.8	76.02	19.5	144	1.2		3.8		323	0.7	90.29	15.4	183	1.0	3.0		409		0.6	114.46																																																																																																																									
29.8	54	2.5	5.8	108	1.3	29.56	24.8	65	2.1			4.8	129	1.1	35.47	19.2	84			1.6	3.7		167	0.8			45.89	18.0		89	1.5			3.5	179		0.8	49.00			16.5	97		1.4	3.2	195	0.7	53.33	18.9		83	1.6	3.6	166	0.8	46.61	CMGV 013/018	461	6	8.6	89.0	14	5.0	3.82	CMGV 012/018	15.9		99	1.4	3.1	198	0.7	55.36	13.9		113		1.2	2.7	226	0.6	63.22	18.6	84		2.7		3.6	169	1.4	47.19	CMGV 023/018	380	8		7.1		73.4	17	4.1	4.63		15.7	100		2.2		3.0	200	1.1	56.05		13.7	114		2.0		2.7	229	1.0	64.01		11.6	136		1.6		2.2	272	0.8	76.02		9.7	161		1.4		1.9	323	0.7	90.29		7.7	204		1.1		1.5	409	0.6	114.46		19.5	81		4.2	3.8		161	2.1	45.21		CMGV 033/018	309		9		5.8	59.8	21	3.3					5.69	14.4	110		3.1		2.8	219			1.6		61.32	12.1	130	2.6	2.3			260	1.3		72.83	9.0			174	1.9			1.7				348		1.0	97.45	7.6		207	1.6			1.5	413		0.8	115.74	6.2	251	1.3	1.2	503	0.7	140.81	5.0	311	1.1	1.0		622	0.6	174.26	37.8	74	1.4	7.3	166	0.8		46.61	CMGV 013/018		228	13		5.7	44.0		28		3.3	7.72	31.8			88	1.2	6.1	198	0.7	55.36	27.8	101		1.1	5.4	226	0.6	63.22	37.3		75	2.4		7.2	169	1.4	47.19		CMGV 023/018	192	15		4.8		37.1		33	2.8	9.17			31.4	90	2.0		6.1	200	1.1	56.05		27.5	102	1.7						5.3	229	1.0	64.01	23.2	121	1.5		4.5	272	0.8	76.02	19.5	144	1.2		3.8		323	0.7	90.29	15.4	183	1.0	3.0		409		0.6	114.46																																																																																																																																			
24.8	65	2.1	4.8	129	1.1	35.47	19.2	84	1.6			3.7	167	0.8	45.89	18.0	89			1.5	3.5		179	0.8			49.00	16.5		97	1.4			3.2	195		0.7	53.33	18.9	83	1.6	3.6		166	0.8	46.61	CMGV 013/018	461	6	8.6	89.0	14	5.0	3.82	CMGV 012/018	15.9		99	1.4	3.1	198	0.7	55.36	13.9		113		1.2	2.7	226	0.6	63.22	18.6	84		2.7		3.6	169	1.4	47.19	CMGV 023/018	380	8		7.1		73.4	17	4.1	4.63		15.7	100		2.2		3.0	200	1.1	56.05		13.7	114		2.0		2.7	229	1.0	64.01		11.6	136		1.6		2.2	272	0.8	76.02		9.7	161		1.4		1.9	323	0.7	90.29		7.7	204		1.1		1.5	409	0.6	114.46		19.5	81		4.2		3.8	161	2.1	45.21		CMGV 033/018	309		9	5.8		59.8	21	3.3			5.69		14.4		110	3.1	2.8	219					1.6	61.32	12.1		130		2.6	2.3			260		1.3	72.83	9.0	174	1.9			1.7	348		1.0	97.45			7.6	207			1.6			1.5	413		0.8	115.74	6.2		251	1.3		1.2	503	0.7		140.81	5.0	311	1.1	1.0	622	0.6	174.26	37.8	74	1.4	7.3	166		0.8	46.61	CMGV 013/018	228	13	5.7	44.0	28	3.3		7.72			31.8	88		1.2	6.1		198	0.7	55.36	27.8	101			1.1	5.4	226	0.6	63.22	37.3	75	2.4		7.2	169	1.4	47.19	CMGV 023/018	192		15	4.8		37.1	33	2.8	9.17			31.4	90		2.0		6.1		200	1.1	56.05			27.5	102	1.7		5.3	229	1.0	64.01		23.2	121	1.5					4.5	272	0.8	76.02	19.5	144	1.2	3.8		323	0.7	90.29	15.4	183	1.0	3.0		409		0.6	114.46																																																																																																																																													
19.2	84	1.6	3.7	167	0.8	45.89	18.0	89	1.5			3.5	179	0.8	49.00	16.5	97			1.4	3.2		195	0.7			53.33	18.9		83	1.6	3.6	166	0.8	46.61		CMGV 013/018	461	6	8.6	89.0	14	5.0	3.82	CMGV 012/018	15.9		99	1.4	3.1	198	0.7	55.36	13.9		113		1.2	2.7	226	0.6	63.22	18.6	84		2.7		3.6	169	1.4	47.19	CMGV 023/018	380	8		7.1		73.4	17	4.1	4.63		15.7	100		2.2		3.0	200	1.1	56.05		13.7	114		2.0		2.7	229	1.0	64.01		11.6	136		1.6		2.2	272	0.8	76.02		9.7	161		1.4		1.9	323	0.7	90.29		7.7	204		1.1		1.5	409	0.6	114.46		19.5	81		4.2		3.8	161	2.1	45.21		CMGV 033/018	309		9		5.8	59.8	21	3.3			5.69		14.4	110		3.1	2.8	219			1.6		61.32		12.1	130	2.6	2.3					260	1.3	72.83		9.0		174	1.9			1.7		348	1.0	97.45	7.6	207			1.6	1.5		413	0.8			115.74	6.2		251	1.3			1.2	503		0.7	140.81	5.0	311	1.1	1.0		622	0.6	174.26		37.8	74	1.4	7.3	166	0.8	46.61	CMGV 013/018	228	13	5.7	44.0	28		3.3	7.72		31.8	88	1.2	6.1	198	0.7		55.36			27.8	101		1.1	5.4	226	0.6	63.22	37.3	75	2.4			7.2	169	1.4	47.19	CMGV 023/018	192	15	4.8		37.1	33	2.8	9.17		31.4		90	2.0		6.1	200	1.1	56.05			27.5	102		1.7		5.3		229	1.0	64.01			23.2	121	1.5		4.5	272	0.8	76.02		19.5	144	1.2				3.8	323	0.7	90.29	15.4	183	1.0	3.0	409		0.6	114.46																																																																																																																																																							
18.0	89	1.5	3.5	179	0.8	49.00	16.5	97	1.4			3.2	195	0.7	53.33	18.9	83			1.6	3.6		166	0.8	46.61	CMGV 013/018	461	6		8.6	89.0	14	5.0	3.82	CMGV 012/018	15.9		99	1.4	3.1	198	0.7	55.36	13.9		113		1.2	2.7	226	0.6	63.22	18.6	84		2.7		3.6	169	1.4	47.19	CMGV 023/018	380	8		7.1		73.4	17	4.1	4.63		15.7	100		2.2		3.0	200	1.1	56.05		13.7	114		2.0		2.7	229	1.0	64.01		11.6	136		1.6		2.2	272	0.8	76.02		9.7	161		1.4		1.9	323	0.7	90.29		7.7	204		1.1		1.5	409	0.6	114.46		19.5	81		4.2		3.8	161	2.1	45.21		CMGV 033/018	309		9		5.8	59.8	21	3.3			5.69		14.4		110	3.1	2.8	219			1.6		61.32	12.1		130	2.6	2.3			260		1.3		72.83	9.0	174	1.9					1.7	348	1.0		97.45		7.6	207			1.6		1.5	413	0.8	115.74	6.2			251	1.3		1.2	503		0.7	140.81	5.0		311	1.1			1.0	622	0.6	174.26	37.8	74	1.4	7.3	166		0.8	46.61	CMGV 013/018		228	13	5.7	44.0	28	3.3	7.72		31.8	88	1.2	6.1	198		0.7	55.36		27.8	101	1.1	5.4	226	0.6		63.22			37.3	75	2.4	7.2	169	1.4	47.19	CMGV 023/018	192	15	4.8			37.1	33	2.8	9.17		31.4	90	2.0		6.1	200	1.1	56.05		27.5		102	1.7		5.3	229	1.0	64.01			23.2	121		1.5		4.5		272	0.8	76.02			19.5	144	1.2		3.8	323	0.7	90.29		15.4	183	1.0			3.0	409	0.6	114.46																																																																																																																																																																
16.5	97	1.4	3.2	195	0.7	53.33	18.9	83	1.6			3.6	166	0.8	46.61	CMGV 013/018	461	6	8.6	89.0	14		5.0	3.82	CMGV 012/018		15.9	99	1.4	3.1	198	0.7	55.36	13.9		113		1.2	2.7	226	0.6	63.22	18.6	84		2.7		3.6	169	1.4	47.19	CMGV 023/018	380	8		7.1		73.4	17	4.1	4.63		15.7	100		2.2		3.0	200	1.1	56.05		13.7	114		2.0		2.7	229	1.0	64.01		11.6	136		1.6		2.2	272	0.8	76.02		9.7	161		1.4		1.9	323	0.7	90.29		7.7	204		1.1		1.5	409	0.6	114.46		19.5	81		4.2		3.8	161	2.1	45.21		CMGV 033/018	309		9		5.8	59.8	21	3.3			5.69		14.4		110	3.1	2.8	219			1.6		61.32		12.1	130	2.6	2.3			260		1.3	72.83		9.0	174	1.9			1.7		348		1.0	97.45	7.6	207					1.6	1.5	413		0.8		115.74	6.2			251		1.3	1.2	503	0.7	140.81			5.0	311	1.1	1.0	622		0.6	174.26	37.8		74	1.4	7.3		166	0.8	46.61	CMGV 013/018	228	13	5.7	44.0	28		3.3	7.72			31.8	88	1.2	6.1	198	0.7	55.36		27.8	101	1.1	5.4	226		0.6	63.22		37.3	75	2.4	7.2	169	1.4		47.19		CMGV 023/018	192	15	4.8	37.1	33	2.8	9.17		31.4	90	2.0			6.1	200	1.1	56.05		27.5	102	1.7		5.3	229	1.0	64.01		23.2		121	1.5		4.5	272	0.8	76.02			19.5	144		1.2		3.8		323	0.7	90.29			15.4	183	1.0		3.0	409	0.6	114.46																																																																																																																																																																										
18.9	83	1.6	3.6	166	0.8	46.61	CMGV 013/018	461	6	8.6	89.0	14	5.0	3.82	CMGV 012/018																																																																																																																																																																																																																																																																																																																																																																																																																																																																														
15.9	99	1.4	3.1	198	0.7	55.36		13.9	113	1.2	2.7	226	0.6	63.22			18.6	84	2.7	3.6	169	1.4	47.19	CMGV 023/018			380	8	7.1	73.4	17	4.1	4.63	15.7		100		2.2	3.0	200	1.1	56.05	13.7	114		2.0		2.7	229	1.0	64.01		11.6	136		1.6		2.2	272	0.8	76.02		9.7	161		1.4		1.9	323	0.7	90.29		7.7	204		1.1		1.5	409	0.6	114.46		19.5	81		4.2		3.8	161	2.1	45.21		CMGV 033/018	309		9		5.8	59.8	21	3.3		5.69	14.4		110		3.1	2.8	219	1.6		61.32	12.1		130		2.6	2.3	260	1.3			72.83		9.0		174	1.9	1.7	348			1.0		97.45		7.6	207	1.6	1.5			413		0.8		115.74	6.2	251	1.3			1.2		503	0.7		140.81	5.0	311			1.1		1.0		622	0.6	174.26	37.8					74	1.4	7.3	166	0.8		46.61	CMGV 013/018			228	13	5.7	44.0	28	3.3	7.72			31.8	88	1.2	6.1	198		0.7	55.36	27.8		101	1.1	5.4		226	0.6	63.22		37.3	75	2.4	7.2	169	1.4	47.19	CMGV 023/018			192	15	4.8	37.1	33	2.8	9.17		31.4	90	2.0	6.1	200		1.1	56.05		27.5	102	1.7	5.3	229	1.0		64.01			23.2	121	1.5	4.5	272	0.8	76.02		19.5	144	1.2			3.8	323	0.7	90.29		15.4	183	1.0		3.0	409	0.6	114.46																																																																																																																																																																																																										
13.9	113	1.2	2.7	226	0.6	63.22		18.6	84	2.7	3.6	169	1.4	47.19			CMGV 023/018	380	8	7.1	73.4	17	4.1				4.63	15.7	100	2.2	3.0	200	1.1	56.05		13.7		114	2.0	2.7	229	1.0	64.01	11.6		136		1.6	2.2	272	0.8		76.02	9.7		161		1.4	1.9	323	0.7		90.29	7.7		204		1.1	1.5	409	0.6		114.46	19.5		81		4.2	3.8	161	2.1		45.21	CMGV 033/018		309		9	5.8	59.8	21			3.3		5.69		14.4	110	3.1	2.8		219	1.6		61.32		12.1	130	2.6	2.3		260	1.3		72.83		9.0	174	1.9	1.7			348		1.0		97.45	7.6	207	1.6			1.5		413		0.8	115.74	6.2	251			1.3		1.2		503	0.7	140.81	5.0			311		1.1	1.0		622	0.6	174.26			37.8		74		1.4	7.3	166	0.8	46.61				CMGV 013/018	228	13	5.7	44.0	28	3.3				7.72	31.8	88	1.2	6.1	198	0.7			55.36	27.8	101	1.1	5.4		226	0.6	63.22		37.3	75	2.4	7.2	169	1.4	47.19		CMGV 023/018	192	15	4.8	37.1	33	2.8				9.17	31.4	90	2.0	6.1	200	1.1		56.05	27.5	102	1.7	5.3		229	1.0		64.01	23.2	121	1.5	4.5	272		0.8			76.02	19.5	144	1.2	3.8	323	0.7		90.29	15.4	183			1.0	3.0	409	0.6		114.46																																																																																																																																																																																																																	
18.6	84	2.7	3.6	169	1.4	47.19		CMGV 023/018	380	8	7.1	73.4	17	4.1				4.63	15.7	100	2.2	3.0	200				1.1	56.05	13.7	114	2.0	2.7	229	1.0		64.01		11.6	136	1.6	2.2	272	0.8	76.02		9.7		161	1.4	1.9	323		0.7	90.29		7.7		204	1.1	1.5	409		0.6	114.46		19.5		81	4.2	3.8	161		2.1	45.21		CMGV 033/018		309	9	5.8	59.8		21			3.3		5.69	14.4	110	3.1			2.8		219		1.6	61.32	12.1	130		2.6	2.3		260		1.3	72.83	9.0	174		1.9	1.7		348		1.0	97.45	7.6	207			1.6		1.5		413	0.8	115.74	6.2			251		1.3		1.2	503	0.7	140.81			5.0		311		1.1	1.0	622	0.6			174.26		37.8	74		1.4	7.3	166			0.8	46.61	CMGV 013/018		228	13	5.7	44.0	28		3.3			7.72	31.8	88	1.2	6.1	198				0.7	55.36	27.8	101	1.1	5.4	226			0.6	63.22	37.3	75	2.4	7.2	169	1.4	47.19		CMGV 023/018	192	15	4.8	37.1	33	2.8			9.17	31.4	90	2.0	6.1	200				1.1	56.05	27.5	102	1.7	5.3	229		1.0	64.01	23.2	121	1.5		4.5	272		0.8	76.02	19.5	144	1.2	3.8		323			0.7	90.29	15.4	183	1.0	3.0	409		0.6	114.46																																																																																																																																																																																																																										
15.7	100	2.2	3.0	200	1.1	56.05			13.7	114	2.0	2.7	229	1.0				64.01	11.6	136	1.6	2.2	272				0.8	76.02	9.7	161	1.4	1.9	323	0.7		90.29		7.7	204	1.1	1.5	409	0.6	114.46		19.5		81	4.2	3.8	161		2.1	45.21		CMGV 033/018		309	9	5.8	59.8		21	3.3		5.69		14.4	110	3.1	2.8		219	1.6				61.32	12.1	130	2.6		2.3			260		1.3	72.83	9.0	174			1.9		1.7		348	1.0	97.45	7.6		207	1.6		1.5		413	0.8	115.74	6.2		251	1.3		1.2		503	0.7	140.81	5.0			311		1.1		1.0	622	0.6	174.26			37.8		74		1.4	7.3	166	0.8			46.61		CMGV 013/018		228	13	5.7	44.0			28		3.3	7.72	31.8	88	1.2	6.1			198	0.7		55.36	27.8	101	1.1	5.4	226		0.6			63.22	37.3	75	2.4	7.2	169				1.4	47.19	CMGV 023/018	192	15	4.8	37.1		33	2.8	9.17	31.4	90	2.0	6.1	200	1.1	56.05			27.5	102	1.7	5.3	229	1.0			64.01	23.2	121	1.5	4.5	272				0.8	76.02	19.5	144	1.2	3.8	323		0.7	90.29	15.4	183	1.0		3.0	409		0.6	114.46																																																																																																																																																																																																																																												
13.7	114	2.0	2.7	229	1.0	64.01			11.6	136	1.6	2.2	272	0.8				76.02	9.7	161	1.4	1.9	323				0.7	90.29	7.7	204	1.1	1.5	409	0.6		114.46		19.5	81	4.2	3.8	161	2.1	45.21		CMGV 033/018		309	9	5.8	59.8		21	3.3				5.69	14.4	110	3.1		2.8	219		1.6		61.32	12.1	130	2.6		2.3	260				1.3	72.83	9.0	174		1.9			1.7		348	1.0	97.45	7.6			207		1.6		1.5	413	0.8	115.74		6.2	251		1.3		1.2	503	0.7	140.81		5.0	311		1.1		1.0	622	0.6	174.26			37.8		74		1.4	7.3	166	0.8			46.61		CMGV 013/018		228	13	5.7	44.0			28			3.3	7.72	31.8	88	1.2			6.1	198	0.7	55.36	27.8	101	1.1	5.4			226	0.6		63.22	37.3	75	2.4	7.2	169		1.4			47.19	CMGV 023/018	192	15	4.8	37.1		33		2.8	9.17		31.4	90	2.0	6.1		200	1.1	56.05	27.5	102	1.7	5.3	229	1.0	64.01			23.2	121	1.5	4.5	272	0.8			76.02	19.5	144	1.2	3.8	323				0.7	90.29	15.4	183	1.0	3.0	409		0.6	114.46																																																																																																																																																																																																																																																					
11.6	136	1.6	2.2	272	0.8	76.02			9.7	161	1.4	1.9	323	0.7				90.29	7.7	204	1.1	1.5	409				0.6	114.46	19.5	81	4.2	3.8	161	2.1		45.21		CMGV 033/018	309	9	5.8	59.8	21	3.3				5.69	14.4	110	3.1		2.8	219				1.6	61.32	12.1	130		2.6	2.3		260		1.3	72.83	9.0	174		1.9	1.7				348	1.0	97.45	7.6		207			1.6		1.5	413	0.8	115.74			6.2		251		1.3	1.2	503	0.7		140.81	5.0		311		1.1	1.0	622	0.6		174.26	37.8		74		1.4	7.3	166	0.8			46.61		CMGV 013/018		228	13	5.7	44.0			28			3.3	7.72	31.8	88	1.2			6.1	198		0.7	55.36	27.8	101	1.1			5.4	226	0.6	63.22	37.3	75	2.4	7.2			169	1.4		47.19	CMGV 023/018	192	15	4.8	37.1	33	2.8			9.17		31.4	90	2.0	6.1		200		1.1	56.05		27.5	102	1.7	5.3		229	1.0	64.01	23.2	121	1.5	4.5	272	0.8	76.02			19.5	144	1.2	3.8	323	0.7			90.29	15.4	183	1.0	3.0	409				0.6	114.46																																																																																																																																																																																																																																																													
9.7	161	1.4	1.9	323	0.7	90.29			7.7	204	1.1	1.5	409	0.6				114.46	19.5	81	4.2	3.8	161				2.1	45.21	CMGV 033/018	309	9	5.8	59.8	21		3.3			5.69	14.4	110	3.1	2.8	219				1.6	61.32	12.1	130		2.6	2.3				260	1.3	72.83	9.0		174	1.9		1.7		348	1.0	97.45	7.6		207	1.6				1.5	413	0.8	115.74		6.2			251		1.3	1.2	503	0.7			140.81		5.0		311	1.1	1.0	622		0.6	174.26		37.8		74	1.4	7.3	166		0.8	46.61		CMGV 013/018		228	13	5.7	44.0			28			3.3	7.72	31.8	88	1.2			6.1	198		0.7	55.36	27.8	101	1.1			5.4	226		0.6	63.22	37.3	75	2.4			7.2	169	1.4	47.19	CMGV 023/018	192	15	4.8	37.1		33	2.8		9.17		31.4	90	2.0	6.1	200	1.1			56.05		27.5	102	1.7	5.3		229		1.0	64.01		23.2	121	1.5	4.5		272	0.8	76.02	19.5	144	1.2	3.8	323	0.7	90.29			15.4	183	1.0	3.0	409	0.6			114.46																																																																																																																																																																																																																																																																							
7.7	204	1.1	1.5	409	0.6	114.46			19.5	81	4.2	3.8	161	2.1				45.21	CMGV 033/018	309	9	5.8	59.8				21	3.3		5.69	14.4	110	3.1	2.8		219			1.6	61.32	12.1	130	2.6	2.3				260	1.3	72.83	9.0		174	1.9				1.7	348	1.0	97.45		7.6	207		1.6		1.5	413	0.8	115.74		6.2	251				1.3	1.2	503	0.7		140.81			5.0		311	1.1	1.0	622			0.6		174.26		37.8	74	1.4	7.3		166	0.8		46.61		CMGV 013/018	228	13	5.7		44.0	28			3.3	7.72	31.8	88	1.2			6.1	198		0.7	55.36	27.8	101	1.1			5.4	226		0.6	63.22	37.3	75	2.4			7.2	169		1.4	47.19	CMGV 023/018	192	15	4.8		37.1	33	2.8	9.17		31.4	90	2.0	6.1		200	1.1		56.05		27.5	102	1.7	5.3	229	1.0			64.01		23.2	121	1.5	4.5		272		0.8	76.02		19.5	144	1.2	3.8		323	0.7	90.29	15.4	183	1.0	3.0	409	0.6	114.46																																																																																																																																																																																																																																																																																		
19.5	81	4.2	3.8	161	2.1	45.21			CMGV 033/018	309	9	5.8	59.8	21				3.3		5.69	14.4	110	3.1				2.8	219		1.6	61.32	12.1	130	2.6		2.3			260	1.3	72.83	9.0	174	1.9				1.7	348	1.0	97.45		7.6	207				1.6	1.5	413	0.8		115.74	6.2		251		1.3	1.2	503	0.7		140.81	5.0				311	1.1	1.0	622		0.6			174.26		37.8	74	1.4	7.3			166		0.8		46.61	CMGV 013/018	228	13		5.7	44.0		28	3.3		7.72	31.8	88		1.2	6.1	198		0.7	55.36	27.8	101	1.1			5.4	226		0.6	63.22	37.3	75	2.4			7.2	169		1.4	47.19	CMGV 023/018	192	15	4.8		37.1	33		2.8	9.17		31.4	90	2.0		6.1	200	1.1	56.05		27.5	102	1.7	5.3		229	1.0		64.01		23.2	121	1.5	4.5	272	0.8			76.02		19.5	144	1.2	3.8		323		0.7	90.29		15.4	183	1.0	3.0		409	0.6	114.46																																																																																																																																																																																																																																																																																									
14.4	110	3.1	2.8	219	1.6	61.32				12.1	130	2.6	2.3	260				1.3		72.83	9.0	174	1.9				1.7	348		1.0	97.45	7.6	207	1.6		1.5			413	0.8	115.74	6.2	251	1.3				1.2	503	0.7	140.81		5.0	311				1.1	1.0	622	0.6		174.26	37.8		74		1.4	7.3	166	0.8		46.61	CMGV 013/018				228	13	5.7	44.0		28			3.3		7.72	31.8	88	1.2			6.1		198	0.7	55.36		27.8	101		1.1	5.4	226	0.6	63.22		37.3	75	2.4		7.2	169	1.4		47.19	CMGV 023/018	192	15	4.8			37.1	33		2.8	9.17	31.4	90	2.0	6.1		200	1.1		56.05	27.5		102	1.7	5.3		229	1.0		64.01	23.2		121	1.5	4.5		272	0.8	76.02	19.5		144	1.2	3.8	323		0.7	90.29		15.4		183	1.0	3.0	409	0.6	114.46																																																																																																																																																																																																																																																																																																															
12.1	130	2.6	2.3	260	1.3	72.83				9.0	174	1.9	1.7	348				1.0		97.45	7.6	207	1.6				1.5	413		0.8	115.74	6.2	251	1.3		1.2			503	0.7	140.81	5.0	311	1.1				1.0	622	0.6	174.26		37.8	74				1.4	7.3	166	0.8		46.61	CMGV 013/018		228		13	5.7	44.0	28		3.3					7.72	31.8	88	1.2		6.1			198	0.7	55.36	27.8	101	1.1			5.4	226	0.6	63.22	37.3		75	2.4		7.2	169	1.4	47.19	CMGV 023/018		192	15	4.8		37.1	33	2.8		9.17		31.4	90	2.0	6.1		200	1.1		56.05	27.5	102	1.7	5.3	229		1.0	64.01		23.2	121		1.5	4.5	272		0.8	76.02		19.5	144		1.2	3.8	323		0.7	90.29	15.4	183		1.0	3.0	409	0.6		114.46																																																																																																																																																																																																																																																																																																																									
9.0	174	1.9	1.7	348	1.0	97.45				7.6	207	1.6	1.5	413				0.8		115.74	6.2	251	1.3				1.2	503		0.7	140.81	5.0	311	1.1		1.0			622	0.6	174.26	37.8	74	1.4				7.3	166	0.8	46.61		CMGV 013/018	228				13	5.7	44.0	28		3.3			7.72		31.8	88	1.2	6.1		198				0.7	55.36	27.8	101	1.1		5.4		226	0.6	63.22	37.3	75	2.4	7.2			169	1.4	47.19	CMGV 023/018	192		15	4.8		37.1	33	2.8	9.17			31.4	90	2.0	6.1	200	1.1	56.05		27.5		102	1.7	5.3	229		1.0	64.01		23.2	121	1.5	4.5	272	0.8		76.02	19.5		144	1.2		3.8	323	0.7		90.29	15.4		183	1.0		3.0	409	0.6		114.46																																																																																																																																																																																																																																																																																																																																			
7.6	207	1.6	1.5	413	0.8	115.74				6.2	251	1.3	1.2	503				0.7		140.81	5.0	311	1.1				1.0	622		0.6	174.26	37.8	74	1.4		7.3			166	0.8	46.61	CMGV 013/018	228	13				5.7	44.0	28	3.3			7.72				31.8	88	1.2	6.1		198			0.7	55.36	27.8	101	1.1	5.4		226		0.6		63.22	37.3	75	2.4	7.2		169		1.4	47.19	CMGV 023/018	192	15	4.8	37.1			33	2.8	9.17		31.4		90	2.0	6.1	200	1.1	56.05	27.5			102	1.7	5.3	229	1.0	64.01	23.2		121		1.5	4.5	272	0.8		76.02	19.5		144	1.2	3.8	323	0.7	90.29		15.4	183		1.0	3.0		409	0.6	114.46																																																																																																																																																																																																																																																																																																																																															
6.2	251	1.3	1.2	503	0.7	140.81				5.0	311	1.1	1.0	622				0.6		174.26	37.8	74	1.4				7.3	166		0.8	46.61	CMGV 013/018	228	13		5.7			44.0	28	3.3		7.72	31.8				88	1.2	6.1	198			0.7			55.36	27.8	101	1.1	5.4		226		0.6	63.22	37.3	75	2.4	7.2	169		1.4		47.19		CMGV 023/018	192	15	4.8	37.1		33		2.8	9.17		31.4	90	2.0	6.1	200		1.1	56.05	27.5		102		1.7	5.3	229	1.0	64.01	23.2	121			1.5	4.5	272	0.8	76.02	19.5	144		1.2		3.8	323	0.7	90.29		15.4	183		1.0	3.0	409	0.6	114.46																																																																																																																																																																																																																																																																																																																																																										
5.0	311	1.1	1.0	622	0.6	174.26				37.8	74	1.4	7.3	166				0.8		46.61	CMGV 013/018	228	13				5.7	44.0		28	3.3		7.72	31.8		88			1.2	6.1	198		0.7	55.36			27.8	101	1.1	5.4	226			0.6	63.22		37.3	75	2.4	7.2	169		1.4		47.19	CMGV 023/018	192	15	4.8	37.1	33		2.8		9.17			31.4	90	2.0	6.1	200	1.1		56.05	27.5		102	1.7	5.3	229	1.0		64.01	23.2	121		1.5		4.5	272	0.8	76.02	19.5	144	1.2			3.8	323	0.7	90.29	15.4	183	1.0		3.0		409	0.6	114.46																																																																																																																																																																																																																																																																																																																																																																				
37.8	74	1.4	7.3	166	0.8	46.61				CMGV 013/018	228	13	5.7	44.0				28		3.3		7.72	31.8				88	1.2		6.1	198		0.7	55.36		27.8	101		1.1	5.4	226		0.6	63.22	37.3		75	2.4	7.2	169	1.4			47.19	CMGV 023/018		192	15	4.8	37.1	33		2.8		9.17		31.4	90	2.0	6.1	200	1.1	56.05		27.5			102	1.7	5.3	229	1.0	64.01		23.2	121		1.5	4.5	272	0.8	76.02		19.5	144	1.2		3.8		323	0.7	90.29	15.4	183	1.0	3.0			409	0.6	114.46																																																																																																																																																																																																																																																																																																																																																																														
31.8	88	1.2	6.1	198	0.7	55.36					27.8	101	1.1	5.4				226		0.6		63.22	37.3			75	2.4	7.2		169	1.4		47.19	CMGV 023/018	192	15	4.8		37.1	33	2.8		9.17	31.4	90		2.0	6.1	200	1.1	56.05			27.5			102	1.7	5.3	229	1.0	64.01	23.2		121		1.5	4.5	272	0.8	76.02	19.5	144		1.2			3.8	323	0.7	90.29	15.4	183		1.0	3.0		409	0.6	114.46																																																																																																																																																																																																																																																																																																																																																																																																			
27.8	101	1.1	5.4	226	0.6	63.22					37.3	75	2.4	7.2		169		1.4		47.19		CMGV 023/018	192		15	4.8	37.1	33		2.8	9.17		31.4		90	2.0	6.1		200	1.1	56.05		27.5	102	1.7		5.3	229	1.0	64.01	23.2	121		1.5			4.5	272	0.8	76.02	19.5	144	1.2		3.8		323	0.7	90.29	15.4	183	1.0	3.0		409			0.6	114.46																																																																																																																																																																																																																																																																																																																																																																																																														
37.3	75	2.4	7.2	169	1.4	47.19	CMGV 023/018				192	15	4.8	37.1	33	2.8		9.17		31.4			90		2.0	6.1	200	1.1		56.05	27.5		102		1.7	5.3	229		1.0	64.01	23.2		121	1.5	4.5		272	0.8	76.02	19.5	144	1.2		3.8			323	0.7	90.29	15.4	183	1.0	3.0		409		0.6	114.46																																																																																																																																																																																																																																																																																																																																																																																																																									
31.4	90	2.0	6.1	200	1.1	56.05					27.5	102	1.7	5.3	229	1.0		64.01		23.2			121	1.5	4.5	272	0.8	76.02		19.5	144		1.2		3.8	323	0.7		90.29	15.4	183		1.0	3.0	409		0.6	114.46																																																																																																																																																																																																																																																																																																																																																																																																																																													
27.5	102	1.7	5.3	229	1.0	64.01					23.2	121	1.5	4.5	272	0.8	76.02	19.5		144			1.2	3.8	323	0.7	90.29	15.4		183	1.0		3.0		409	0.6	114.46																																																																																																																																																																																																																																																																																																																																																																																																																																																								
23.2	121	1.5	4.5	272	0.8	76.02		19.5			144	1.2	3.8	323	0.7	90.29	15.4	183		1.0			3.0	409	0.6	114.46																																																																																																																																																																																																																																																																																																																																																																																																																																																																			
19.5	144	1.2	3.8	323	0.7	90.29		15.4			183	1.0	3.0	409	0.6	114.46																																																																																																																																																																																																																																																																																																																																																																																																																																																																													
15.4	183	1.0	3.0	409	0.6	114.46																																																																																																																																																																																																																																																																																																																																																																																																																																																																																							

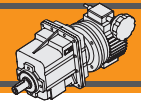

Dati tecnici

Technical data

P ₁ [kW]	velocità massima max speed			velocità minima min speed			i	
	n ₂ [min ⁻¹]	M ₂ [Nm]	sf	n ₂ [min ⁻¹]	M ₂ [Nm]	sf		

P ₁ [kW]	velocità massima max speed			velocità minima min speed			i	
	n ₂ [min ⁻¹]	M ₂ [Nm]	sf	n ₂ [min ⁻¹]	M ₂ [Nm]	sf		

0.55

71B2 n ₁ =2800 [min ⁻¹]	44.2	93	2.9	8.8	255	1.4	45.21	CMGV 033/037
	32.6	127	2.1	6.5	346	1.0	61.32	
	27.5	151	1.8	5.5	411	0.8	72.83	
	20.5	202	1.3	4.1	550	0.6	97.45	CMGV 043/037
	32.6	127	3.5	6.5	346	1.7	61.32	
	27.5	151	3.0	5.5	411	1.4	72.83	
	20.5	202	2.2	4.1	550	1.0	97.45	
	17.3	239	1.9	3.5	653	0.9	115.74	
	14.2	291	1.5	2.8	794	0.7	140.81	
	11.5	360	1.2	2.3	983	0.6	174.26	
18.4	224	3.6	3.7	612	1.7	108.43	CMGV 053/037	
15.5	266	3.0	3.1	727	1.4	128.84		
11.6	356	2.2	2.3	972	1.1	172.32		
10.7	385	2.1	2.1	1050	1.0	186.17		
9.3	447	1.8	1.9	1219	0.8	216.19		
8.0	515	1.6	1.6	1404	0.7	248.99		
6.9	598	1.3	1.4	1631	0.6	289.15		

0.75

80B4 n ₁ =1400 [min ⁻¹]	22.1	255	2.2	4.4	510	1.1	45.21	CMGV 043/075
	16.3	346	1.6	3.3	692	0.8	61.32	
	13.7	411	1.4	2.7	821	0.7	72.83	
	17.8	316	3.2	3.6	632	1.6	56.05	CMGV 053/075
	15.5	364	2.8	3.1	727	1.4	64.48	
	13.3	423	2.4	2.7	846	1.2	74.96	
	12.3	457	2.2	2.5	914	1.1	81.07	
	11.6	486	2.1	2.3	973	1.1	86.24	
	9.2	612	1.6	1.8	1223	0.8	108.43	
	7.8	727	1.4	1.6	1453	0.7	128.84	

1.1

80B2 n ₁ =2800 [min ⁻¹]	547	15	5.8	109	42	2.7	3.66	CMGV 022/075	
	451	19	4.8	90.3	51	2.3	4.43		
	367	23	3.9	73.4	63	1.8	5.45		
	271	31	3.4	54.1	85	1.6	7.39		
	228	37	2.9	45.6	101	1.4	8.78		
	201	42	2.5	40.3	114	1.2	9.93		
	182	47	3.8	36.3	127	1.8	11.01		
	166	51	3.5	33.2	139	1.7	12.05		
	151	56	3.2	30.3	152	1.5	13.21		
	135	63	2.8	27.0	171	1.3	14.81		
	117	72	2.0	23.4	197	0.9	17.10	CMGV 032/075	
	110	77	1.8	21.9	210	0.9	18.26		
	99.6	85	2.1	19.9	231	1.0	20.08		
	83.9	101	1.8	16.8	275	0.8	23.85		
	66.8	126	1.4	13.4	345	0.7	29.93		
	55.7	152	1.2	11.1	414	0.6	35.91		
	131	65	3.9	26.1	176	1.8	15.30		
	110	77	3.2	22.0	210	1.5	18.21		
	104	81	3.1	20.8	222	1.5	19.24		
	94.6	89	2.8	18.9	244	1.3	21.15		
	65.4	129	2.1	13.1	352	1.0	30.57	CMGV 043/075	
	45.3	187	1.4	9.1	509	0.7	44.18		
	39.0	217	1.2	7.8	591	0.6	51.30		
	44.2	187	2.4	8.8	510	1.1	45.21		
	32.6	254	1.8	6.5	692	0.8	61.32		
	27.5	301	1.5	5.5	821	0.7	72.83		
	31.0	267	3.0	6.2	727	1.4	64.48		CMGV 053/075
	26.7	310	2.6	5.3	846	1.2	74.96		
	24.7	335	2.4	4.9	914	1.1	81.07		
	23.2	357	2.2	4.6	973	1.1	86.24		
	18.4	448	1.8	3.7	1223	0.8	108.43		
	15.5	533	1.5	3.1	1453	0.7	128.84		

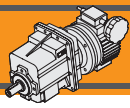

0.75

80B4 n ₁ =1400 [min ⁻¹]	274	21	5.3	54.6	42	2.7	3.66	CMGV 022/075	
	225	26	4.4	45.1	51	2.3	4.43		
	184	31	3.6	36.7	63	1.8	5.45		
	135	43	3.2	27.1	85	1.6	7.39		
	114	51	2.7	22.8	101	1.4	8.78		
	101	57	2.3	20.1	114	1.2	9.93		
	90.8	63	3.5	18.2	127	1.8	11.01		
	83.0	69	3.2	16.6	139	1.7	12.05		
	75.7	76	2.9	15.1	152	1.5	13.21		
	67.5	85	2.6	13.5	171	1.3	14.81		
	58.5	98	1.8	11.7	197	0.9	17.10	CMGV 032/075	
	54.8	105	1.7	11.0	210	0.9	18.26		
	49.8	116	1.9	10.0	231	1.0	20.08		
	41.9	137	1.6	8.4	275	0.8	23.85		
	33.4	172	1.3	6.7	345	0.7	29.93		
	27.8	207	1.1	5.6	414	0.6	35.91		
	91.5	63	3.2	18.3	126	1.6	10.93		CMGV 032/075
	79.3	73	3.9	15.9	145	2.0	12.60		
	75.2	77	3.7	15.0	153	1.9	13.30		
	65.4	88	3.6	13.1	176	1.8	15.30		
54.9	105	3.0	11.0	210	1.5	18.21			
52.0	111	2.8	10.4	222	1.5	19.24			
47.3	122	2.6	9.5	244	1.3	21.15			
32.7	176	1.9	6.5	352	1.0	30.57			
22.6	254	1.3	4.5	509	0.7	44.18			
19.5	295	1.1	3.9	591	0.6	51.30			



Dati tecnici

Technical data

P ₁ [kW]	velocità massima max speed			velocità minima min speed			i		P ₁ [kW]	velocità massima max speed			velocità minima min speed			i																																																																																																																																																																																																																																																																																																																																																																																																																																																																																																																																																																																																																																																																																																																																																																																																																																																										
	n ₂ [min ⁻¹]	M ₂ [Nm]	sf	n ₂ [min ⁻¹]	M ₂ [Nm]	sf				n ₂ [min ⁻¹]	M ₂ [Nm]	sf	n ₂ [min ⁻¹]	M ₂ [Nm]	sf																																																																																																																																																																																																																																																																																																																																																																																																																																																																																																																																																																																																																																																																																																																																																																																																																																																											
1.1									1.5																																																																																																																																																																																																																																																																																																																																																																																																																																																																																																																																																																																																																																																																																																																																																																																																																																																																	
90S4 n ₁ =1400 [min ⁻¹]	267	32	5.2	53.4	65	2.7	3.74	CMGV 032/15	90L4 n ₁ =1400 [min ⁻¹]	126	91	3.2	25.2	183	1.6	7.93	CMGV 042/15																																																																																																																																																																																																																																																																																																																																																																																																																																																																																																																																																																																																																																																																																																																																																																																																																																																									
	222	39	4.3	44.4	78	2.2	4.50			182	47	3.5	36.5	95	1.8	5.48			159	55	3.7	31.7	109	1.9	6.31		126	69	2.9	25.2	137	1.5	7.93		110	78	2.6	22.0	157	1.3	9.08		91.5	94	2.1	18.3	189	1.1	10.93		79.3	109	2.6	15.9	218	1.3	12.60		75.2	115	2.4	15.0	230	1.3	13.30		65.4	132	2.4	13.1	264	1.2	15.30		54.9	157	2.0	11.0	315	1.0	18.21		52.0	166	1.9	10.4	332	1.0	19.24		47.3	183	1.7	9.5	365	0.9	21.15		32.7	264	1.3	6.5	528	0.7	30.57		91.5	94	3.3	18.3	189	1.7	10.93	CMGV 042/15	31.1	370	2.7	6.2	740	1.4	32.13	CMGV 052/15		79.3	109	3.6	15.9	218	1.8	12.60		75.2	115	3.4	15.0	230	1.8	13.30		65.4	132	3.6	13.1	264	1.8	15.30		54.9	157	3.0	11.0	315	1.5	18.21		52.0	166	2.8	10.4	332	1.5	19.24		32.7	264	2.1	6.5	528	1.1	30.57		22.6	382	1.5	4.5	763	0.8	44.18		19.5	443	1.3	3.9	886	0.6	51.30		31.1	278	3.6	6.2	555	1.9	32.13	CMGV 052/15	21.6	534	1.9	4.3	1067	1.0	46.31		21.6	400	2.5	4.3	800	1.3	46.31		22.1	382	1.5	4.4	765	0.8	45.21	CMGV 043/15	17.8	632	1.6	3.6	1264	0.8	56.05	CMGV 053/15		16.3	519	1.1	3.3	1038	0.6	61.32		17.8	474	2.1	3.6	948	1.1	56.05		15.5	545	1.8	3.1	1091	0.9	64.48		13.3	634	1.6	2.7	1268	0.8	74.96		12.3	686	1.5	2.5	1372	0.8	81.07		11.6	730	1.4	2.3	1459	0.7	86.24		9.2	917	1.1	1.8	1835	0.6	108.43		11.6	730	1.4	2.3	1459	0.7	86.24		9.2	917	1.1	1.8	1835	0.6	108.43	2.2									2.2																		90L2 n ₁ =2800 [min ⁻¹]	534	32	4.1	107	86	2.0	3.74	CMGV 032/15											444	39	3.4	88.8	104	1.7	4.50											365	47	2.8	72.9	126	1.4	5.48											317	55	2.9	63.4	145	1.4	6.31											252	69	2.3	50.4	183	1.1	7.93											220	78	2.0	44.1	209	1.0	9.08											183	94	1.7	36.6	252	0.8	10.93											159	109	2.0	31.7	290	1.0	12.60											150	115	1.9	30.1	306	0.9	13.30											131	132	1.9	26.1	353	0.9	15.30											110	157	1.6	22.0	420	0.8	18.21											104	166	1.5	20.8	443	0.7	19.24											94.6	183	1.4	18.9	487	0.7	21.15											252	69	3.4	50.4	183	1.6	7.93	CMGV 042/15											220	78	3.2	44.1	209	1.5	9.08											183	94	2.6	36.6	252	1.3	10.93											159	109	2.9	31.7	290	1.4	12.60											150	115	2.7	30.1	306	1.3	13.30											131	132	2.8	26.1	353	1.4	15.30											110	157	2.4	22.0	420	1.2	18.21											104	166	2.2	20.8	443	1.1	19.24											65.4	264	1.7	13.1	704	0.8	30.57											45.3	382	1.2	9.1	1018	0.6	44.18	1.5									1.5									90L4 n ₁ =1400 [min ⁻¹]	267	43	3.9	53.4	86	2.0	3.74	CMGV 032/15											222	52	3.2	44.4	104	1.7	4.50		182	63	2.7	36.5	126	1.4	5.48		159	73	2.8	31.7	145	1.4	6.31		126	91	2.2	25.2	183	1.1	7.93		110	105	1.9	22.0	209	1.0	9.08		91.5	126	1.6	18.3	252	0.8	10.93		79.3	145	1.9	15.9	290	1.0	12.60		75.2	153	1.8	15.0	306	0.9	13.30		65.4	176	1.8	13.1	353	0.9	15.30		54.9	210	1.5	11.0	420	0.8	18.21		52.0	222	1.4	10.4	443	0.7	19.24		47.3	244	1.3	9.5	487	0.7	21.15
	182	47	3.5	36.5	95	1.8	5.48			159	55	3.7	31.7	109	1.9	6.31			126	69	2.9	25.2	137	1.5	7.93		110	78	2.6	22.0	157	1.3	9.08		91.5	94	2.1	18.3	189	1.1	10.93		79.3	109	2.6	15.9	218	1.3	12.60		75.2	115	2.4	15.0	230	1.3	13.30		65.4	132	2.4	13.1	264	1.2	15.30		54.9	157	2.0	11.0	315	1.0	18.21		52.0	166	1.9	10.4	332	1.0	19.24		47.3	183	1.7	9.5	365	0.9	21.15		32.7	264	1.3	6.5	528	0.7	30.57		91.5	94	3.3	18.3	189	1.7	10.93	CMGV 042/15	31.1	370	2.7	6.2	740	1.4	32.13		CMGV 052/15		79.3	109	3.6	15.9	218		1.8	12.60		75.2	115	3.4	15.0	230	1.8	13.30		65.4	132	3.6	13.1	264	1.8	15.30		54.9	157	3.0	11.0	315	1.5	18.21		52.0	166	2.8	10.4	332	1.5	19.24		32.7	264	2.1	6.5	528	1.1	30.57		22.6	382	1.5	4.5	763	0.8	44.18		19.5	443	1.3	3.9	886	0.6	51.30		31.1	278	3.6	6.2	555	1.9	32.13	CMGV 052/15	21.6	534	1.9	4.3	1067		1.0	46.31		21.6	400	2.5	4.3	800	1.3	46.31		22.1	382	1.5	4.4	765	0.8	45.21	CMGV 043/15	17.8	632	1.6	3.6		1264	0.8	56.05	CMGV 053/15		16.3	519		1.1	3.3	1038	0.6	61.32		17.8	474	2.1	3.6	948	1.1	56.05		15.5	545	1.8	3.1	1091	0.9	64.48		13.3	634	1.6	2.7	1268	0.8	74.96		12.3	686	1.5	2.5	1372	0.8	81.07		11.6	730	1.4	2.3	1459	0.7	86.24		9.2	917	1.1	1.8	1835	0.6	108.43		11.6	730	1.4	2.3	1459	0.7	86.24		9.2	917	1.1	1.8	1835	0.6	108.43	2.2									2.2																		90L2 n ₁ =2800 [min ⁻¹]	534	32	4.1	107	86	2.0	3.74	CMGV 032/15												444	39	3.4	88.8	104	1.7	4.50											365	47	2.8	72.9	126	1.4	5.48											317	55	2.9	63.4	145	1.4	6.31											252	69	2.3	50.4	183	1.1	7.93											220	78	2.0	44.1	209	1.0	9.08											183	94	1.7	36.6	252	0.8	10.93											159	109	2.0	31.7	290	1.0	12.60											150	115	1.9	30.1	306	0.9	13.30											131	132	1.9	26.1	353	0.9	15.30											110	157	1.6	22.0	420	0.8	18.21											104	166	1.5	20.8	443	0.7	19.24											94.6	183	1.4	18.9	487	0.7	21.15											252	69	3.4	50.4	183	1.6	7.93	CMGV 042/15												220	78	3.2	44.1	209	1.5	9.08											183	94	2.6	36.6	252	1.3	10.93											159	109	2.9	31.7	290	1.4	12.60											150	115	2.7	30.1	306	1.3	13.30											131	132	2.8	26.1	353	1.4	15.30											110	157	2.4	22.0	420	1.2	18.21											104	166	2.2	20.8	443	1.1	19.24											65.4	264	1.7	13.1	704	0.8	30.57											45.3	382	1.2	9.1	1018	0.6	44.18	1.5									1.5									90L4 n ₁ =1400 [min ⁻¹]	267	43	3.9	53.4	86	2.0	3.74	CMGV 032/15												222	52	3.2	44.4	104	1.7	4.50		182	63	2.7	36.5	126	1.4	5.48		159	73	2.8	31.7	145	1.4	6.31		126	91	2.2	25.2	183	1.1	7.93		110	105	1.9	22.0	209	1.0	9.08		91.5	126	1.6	18.3	252	0.8	10.93		79.3	145	1.9	15.9	290	1.0	12.60		75.2	153	1.8	15.0	306	0.9	13.30		65.4	176	1.8	13.1	353	0.9	15.30		54.9	210	1.5	11.0	420	0.8	18.21		52.0	222	1.4	10.4	443	0.7	19.24		47.3	244	1.3	9.5	487	0.7	21.15
	159	55	3.7	31.7	109	1.9	6.31			126	69	2.9	25.2	137	1.5	7.93			110	78	2.6	22.0	157	1.3	9.08		91.5	94	2.1	18.3	189	1.1	10.93		79.3	109	2.6	15.9	218	1.3	12.60		75.2	115	2.4	15.0	230	1.3	13.30		65.4	132	2.4	13.1	264	1.2	15.30		54.9	157	2.0	11.0	315	1.0	18.21		52.0	166	1.9	10.4	332	1.0	19.24		47.3	183	1.7	9.5	365	0.9	21.15		32.7	264	1.3	6.5	528	0.7	30.57		91.5	94	3.3	18.3	189	1.7	10.93	CMGV 042/15	31.1	370	2.7	6.2	740	1.4	32.13		CMGV 052/15		79.3	109	3.6	15.9	218			1.8	12.60		75.2	115	3.4		15.0	230	1.8	13.30		65.4	132	3.6	13.1	264	1.8	15.30		54.9	157	3.0	11.0	315	1.5	18.21		52.0	166	2.8	10.4	332	1.5	19.24		32.7	264	2.1	6.5	528	1.1	30.57		22.6	382	1.5	4.5	763	0.8	44.18		19.5	443	1.3	3.9	886	0.6	51.30		31.1	278	3.6	6.2	555	1.9	32.13	CMGV 052/15	21.6	534	1.9	4.3	1067		1.0	46.31		21.6	400		2.5	4.3	800	1.3	46.31		22.1	382	1.5	4.4	765	0.8	45.21	CMGV 043/15	17.8	632	1.6	3.6		1264	0.8	56.05	CMGV 053/15			16.3	519		1.1	3.3	1038		0.6	61.32		17.8	474	2.1	3.6	948	1.1	56.05		15.5	545	1.8	3.1	1091	0.9	64.48		13.3	634	1.6	2.7	1268	0.8	74.96		12.3	686	1.5	2.5	1372	0.8	81.07		11.6	730	1.4	2.3	1459	0.7	86.24		9.2	917	1.1	1.8	1835	0.6	108.43		11.6	730	1.4	2.3	1459	0.7	86.24		9.2	917	1.1	1.8	1835	0.6	108.43	2.2									2.2																		90L2 n ₁ =2800 [min ⁻¹]	534	32	4.1	107	86	2.0	3.74	CMGV 032/15													444	39	3.4	88.8	104	1.7	4.50											365	47	2.8	72.9	126	1.4	5.48											317	55	2.9	63.4	145	1.4	6.31											252	69	2.3	50.4	183	1.1	7.93											220	78	2.0	44.1	209	1.0	9.08											183	94	1.7	36.6	252	0.8	10.93											159	109	2.0	31.7	290	1.0	12.60											150	115	1.9	30.1	306	0.9	13.30											131	132	1.9	26.1	353	0.9	15.30											110	157	1.6	22.0	420	0.8	18.21											104	166	1.5	20.8	443	0.7	19.24											94.6	183	1.4	18.9	487	0.7	21.15											252	69	3.4	50.4	183	1.6	7.93	CMGV 042/15													220	78	3.2	44.1	209	1.5	9.08											183	94	2.6	36.6	252	1.3	10.93											159	109	2.9	31.7	290	1.4	12.60											150	115	2.7	30.1	306	1.3	13.30											131	132	2.8	26.1	353	1.4	15.30											110	157	2.4	22.0	420	1.2	18.21											104	166	2.2	20.8	443	1.1	19.24											65.4	264	1.7	13.1	704	0.8	30.57											45.3	382	1.2	9.1	1018	0.6	44.18	1.5									1.5									90L4 n ₁ =1400 [min ⁻¹]	267	43	3.9	53.4	86	2.0	3.74	CMGV 032/15													222	52	3.2	44.4	104	1.7	4.50		182	63	2.7	36.5	126	1.4	5.48		159	73	2.8	31.7	145	1.4	6.31		126	91	2.2	25.2	183	1.1	7.93		110	105	1.9	22.0	209	1.0	9.08		91.5	126	1.6	18.3	252	0.8	10.93		79.3	145	1.9	15.9	290	1.0	12.60		75.2	153	1.8	15.0	306	0.9	13.30		65.4	176	1.8	13.1	353	0.9	15.30		54.9	210	1.5	11.0	420	0.8	18.21		52.0	222	1.4	10.4	443	0.7	19.24		47.3	244	1.3	9.5	487	0.7	21.15
	126	69	2.9	25.2	137	1.5	7.93			110	78	2.6	22.0	157	1.3	9.08			91.5	94	2.1	18.3	189	1.1	10.93		79.3	109	2.6	15.9	218	1.3	12.60		75.2	115	2.4	15.0	230	1.3	13.30		65.4	132	2.4	13.1	264	1.2	15.30		54.9	157	2.0	11.0	315	1.0	18.21		52.0	166	1.9	10.4	332	1.0	19.24		47.3	183	1.7	9.5	365	0.9	21.15		32.7	264	1.3	6.5	528	0.7	30.57		91.5	94	3.3	18.3	189	1.7	10.93	CMGV 042/15	31.1	370	2.7	6.2	740	1.4	32.13		CMGV 052/15		79.3	109	3.6	15.9	218			1.8	12.60		75.2	115	3.4			15.0	230	1.8	13.30		65.4		132	3.6	13.1	264	1.8	15.30		54.9	157	3.0	11.0	315	1.5	18.21		52.0	166	2.8	10.4	332	1.5	19.24		32.7	264	2.1	6.5	528	1.1	30.57		22.6	382	1.5	4.5	763	0.8	44.18		19.5	443	1.3	3.9	886	0.6	51.30		31.1	278	3.6	6.2	555	1.9	32.13	CMGV 052/15	21.6	534	1.9	4.3	1067		1.0	46.31		21.6	400		2.5	4.3	800	1.3	46.31			22.1	382	1.5	4.4	765	0.8	45.21	CMGV 043/15	17.8	632	1.6	3.6		1264	0.8	56.05	CMGV 053/15			16.3	519			1.1	3.3	1038		0.6	61.32			17.8	474	2.1	3.6	948	1.1	56.05		15.5	545	1.8	3.1	1091	0.9	64.48		13.3	634	1.6	2.7	1268	0.8	74.96		12.3	686	1.5	2.5	1372	0.8	81.07		11.6	730	1.4	2.3	1459	0.7	86.24		9.2	917	1.1	1.8	1835	0.6	108.43		11.6	730	1.4	2.3	1459	0.7	86.24		9.2	917	1.1	1.8	1835	0.6	108.43	2.2									2.2																		90L2 n ₁ =2800 [min ⁻¹]	534	32	4.1	107	86	2.0	3.74	CMGV 032/15														444	39	3.4	88.8	104	1.7	4.50											365	47	2.8	72.9	126	1.4	5.48											317	55	2.9	63.4	145	1.4	6.31											252	69	2.3	50.4	183	1.1	7.93											220	78	2.0	44.1	209	1.0	9.08											183	94	1.7	36.6	252	0.8	10.93											159	109	2.0	31.7	290	1.0	12.60											150	115	1.9	30.1	306	0.9	13.30											131	132	1.9	26.1	353	0.9	15.30											110	157	1.6	22.0	420	0.8	18.21											104	166	1.5	20.8	443	0.7	19.24											94.6	183	1.4	18.9	487	0.7	21.15											252	69	3.4	50.4	183	1.6	7.93	CMGV 042/15														220	78	3.2	44.1	209	1.5	9.08											183	94	2.6	36.6	252	1.3	10.93											159	109	2.9	31.7	290	1.4	12.60											150	115	2.7	30.1	306	1.3	13.30											131	132	2.8	26.1	353	1.4	15.30											110	157	2.4	22.0	420	1.2	18.21											104	166	2.2	20.8	443	1.1	19.24											65.4	264	1.7	13.1	704	0.8	30.57											45.3	382	1.2	9.1	1018	0.6	44.18	1.5									1.5									90L4 n ₁ =1400 [min ⁻¹]	267	43	3.9	53.4	86	2.0	3.74	CMGV 032/15														222	52	3.2	44.4	104	1.7	4.50		182	63	2.7	36.5	126	1.4	5.48		159	73	2.8	31.7	145	1.4	6.31		126	91	2.2	25.2	183	1.1	7.93		110	105	1.9	22.0	209	1.0	9.08		91.5	126	1.6	18.3	252	0.8	10.93		79.3	145	1.9	15.9	290	1.0	12.60		75.2	153	1.8	15.0	306	0.9	13.30		65.4	176	1.8	13.1	353	0.9	15.30		54.9	210	1.5	11.0	420	0.8	18.21		52.0	222	1.4	10.4	443	0.7	19.24		47.3	244	1.3	9.5	487	0.7	21.15
	110	78	2.6	22.0	157	1.3	9.08			91.5	94	2.1	18.3	189	1.1	10.93			79.3	109	2.6	15.9	218	1.3	12.60		75.2	115	2.4	15.0	230	1.3	13.30		65.4	132	2.4	13.1	264	1.2	15.30		54.9	157	2.0	11.0	315	1.0	18.21		52.0	166	1.9	10.4	332	1.0	19.24		47.3	183	1.7	9.5	365	0.9	21.15		32.7	264	1.3	6.5	528	0.7	30.57		91.5	94	3.3	18.3	189	1.7	10.93	CMGV 042/15	31.1	370	2.7	6.2	740	1.4	32.13		CMGV 052/15		79.3	109	3.6	15.9	218			1.8	12.60		75.2	115	3.4			15.0	230	1.8	13.30		65.4			132	3.6	13.1	264	1.8	15.30			54.9	157	3.0	11.0	315	1.5	18.21		52.0	166	2.8	10.4	332	1.5	19.24		32.7	264	2.1	6.5	528	1.1	30.57		22.6	382	1.5	4.5	763	0.8	44.18		19.5	443	1.3	3.9	886	0.6	51.30		31.1	278	3.6	6.2	555	1.9	32.13	CMGV 052/15	21.6	534	1.9	4.3	1067		1.0	46.31		21.6	400		2.5	4.3	800	1.3	46.31			22.1	382	1.5	4.4		765	0.8	45.21	CMGV 043/15	17.8	632	1.6	3.6		1264	0.8	56.05	CMGV 053/15			16.3	519			1.1	3.3	1038			0.6	61.32			17.8	474	2.1		3.6	948	1.1	56.05		15.5	545	1.8	3.1	1091	0.9	64.48		13.3	634	1.6	2.7	1268	0.8	74.96		12.3	686	1.5	2.5	1372	0.8	81.07		11.6	730	1.4	2.3	1459	0.7	86.24		9.2	917	1.1	1.8	1835	0.6	108.43		11.6	730	1.4	2.3	1459	0.7	86.24		9.2	917	1.1	1.8	1835	0.6	108.43	2.2									2.2																		90L2 n ₁ =2800 [min ⁻¹]	534	32	4.1	107	86	2.0	3.74	CMGV 032/15															444	39	3.4	88.8	104	1.7	4.50											365	47	2.8	72.9	126	1.4	5.48											317	55	2.9	63.4	145	1.4	6.31											252	69	2.3	50.4	183	1.1	7.93											220	78	2.0	44.1	209	1.0	9.08											183	94	1.7	36.6	252	0.8	10.93											159	109	2.0	31.7	290	1.0	12.60											150	115	1.9	30.1	306	0.9	13.30											131	132	1.9	26.1	353	0.9	15.30											110	157	1.6	22.0	420	0.8	18.21											104	166	1.5	20.8	443	0.7	19.24											94.6	183	1.4	18.9	487	0.7	21.15											252	69	3.4	50.4	183	1.6	7.93	CMGV 042/15															220	78	3.2	44.1	209	1.5	9.08											183	94	2.6	36.6	252	1.3	10.93											159	109	2.9	31.7	290	1.4	12.60											150	115	2.7	30.1	306	1.3	13.30											131	132	2.8	26.1	353	1.4	15.30											110	157	2.4	22.0	420	1.2	18.21											104	166	2.2	20.8	443	1.1	19.24											65.4	264	1.7	13.1	704	0.8	30.57											45.3	382	1.2	9.1	1018	0.6	44.18	1.5									1.5									90L4 n ₁ =1400 [min ⁻¹]	267	43	3.9	53.4	86	2.0	3.74	CMGV 032/15															222	52	3.2	44.4	104	1.7	4.50		182	63	2.7	36.5	126	1.4	5.48		159	73	2.8	31.7	145	1.4	6.31		126	91	2.2	25.2	183	1.1	7.93		110	105	1.9	22.0	209	1.0	9.08		91.5	126	1.6	18.3	252	0.8	10.93		79.3	145	1.9	15.9	290	1.0	12.60		75.2	153	1.8	15.0	306	0.9	13.30		65.4	176	1.8	13.1	353	0.9	15.30		54.9	210	1.5	11.0	420	0.8	18.21		52.0	222	1.4	10.4	443	0.7	19.24		47.3	244	1.3	9.5	487	0.7	21.15
	91.5	94	2.1	18.3	189	1.1	10.93			79.3	109	2.6	15.9	218	1.3	12.60			75.2	115	2.4	15.0	230	1.3	13.30		65.4	132	2.4	13.1	264	1.2	15.30		54.9	157	2.0	11.0	315	1.0	18.21		52.0	166	1.9	10.4	332	1.0	19.24		47.3	183	1.7	9.5	365	0.9	21.15		32.7	264	1.3	6.5	528	0.7	30.57		91.5	94	3.3	18.3	189	1.7	10.93	CMGV 042/15	31.1	370	2.7	6.2	740	1.4	32.13		CMGV 052/15		79.3	109	3.6	15.9	218			1.8	12.60		75.2	115	3.4			15.0	230	1.8	13.30		65.4			132	3.6	13.1	264	1.8	15.30				54.9	157	3.0	11.0	315		1.5	18.21		52.0	166	2.8	10.4	332	1.5	19.24		32.7	264	2.1	6.5	528	1.1	30.57		22.6	382	1.5	4.5	763	0.8	44.18		19.5	443	1.3	3.9	886	0.6	51.30		31.1	278	3.6	6.2	555	1.9	32.13	CMGV 052/15	21.6	534	1.9	4.3	1067		1.0	46.31		21.6	400		2.5	4.3	800	1.3	46.31			22.1	382	1.5	4.4		765	0.8	45.21	CMGV 043/15	17.8		632	1.6	3.6		1264	0.8	56.05	CMGV 053/15			16.3	519			1.1	3.3	1038			0.6	61.32				17.8	474	2.1		3.6	948	1.1		56.05		15.5	545	1.8	3.1	1091	0.9	64.48		13.3	634	1.6	2.7	1268	0.8	74.96		12.3	686	1.5	2.5	1372	0.8	81.07		11.6	730	1.4	2.3	1459	0.7	86.24		9.2	917	1.1	1.8	1835	0.6	108.43		11.6	730	1.4	2.3	1459	0.7	86.24		9.2	917	1.1	1.8	1835	0.6	108.43	2.2									2.2																		90L2 n ₁ =2800 [min ⁻¹]	534	32	4.1	107	86	2.0	3.74	CMGV 032/15																444	39	3.4	88.8	104	1.7	4.50											365	47	2.8	72.9	126	1.4	5.48											317	55	2.9	63.4	145	1.4	6.31											252	69	2.3	50.4	183	1.1	7.93											220	78	2.0	44.1	209	1.0	9.08											183	94	1.7	36.6	252	0.8	10.93											159	109	2.0	31.7	290	1.0	12.60											150	115	1.9	30.1	306	0.9	13.30											131	132	1.9	26.1	353	0.9	15.30											110	157	1.6	22.0	420	0.8	18.21											104	166	1.5	20.8	443	0.7	19.24											94.6	183	1.4	18.9	487	0.7	21.15											252	69	3.4	50.4	183	1.6	7.93	CMGV 042/15																220	78	3.2	44.1	209	1.5	9.08											183	94	2.6	36.6	252	1.3	10.93											159	109	2.9	31.7	290	1.4	12.60											150	115	2.7	30.1	306	1.3	13.30											131	132	2.8	26.1	353	1.4	15.30											110	157	2.4	22.0	420	1.2	18.21											104	166	2.2	20.8	443	1.1	19.24											65.4	264	1.7	13.1	704	0.8	30.57											45.3	382	1.2	9.1	1018	0.6	44.18	1.5									1.5									90L4 n ₁ =1400 [min ⁻¹]	267	43	3.9	53.4	86	2.0	3.74	CMGV 032/15																222	52	3.2	44.4	104	1.7	4.50		182	63	2.7	36.5	126	1.4	5.48		159	73	2.8	31.7	145	1.4	6.31		126	91	2.2	25.2	183	1.1	7.93		110	105	1.9	22.0	209	1.0	9.08		91.5	126	1.6	18.3	252	0.8	10.93		79.3	145	1.9	15.9	290	1.0	12.60		75.2	153	1.8	15.0	306	0.9	13.30		65.4	176	1.8	13.1	353	0.9	15.30		54.9	210	1.5	11.0	420	0.8	18.21		52.0	222	1.4	10.4	443	0.7	19.24		47.3	244	1.3	9.5	487	0.7	21.15
	79.3	109	2.6	15.9	218	1.3	12.60			75.2	115	2.4	15.0	230	1.3	13.30			65.4	132	2.4	13.1	264	1.2	15.30		54.9	157	2.0	11.0	315	1.0	18.21		52.0	166	1.9	10.4	332	1.0	19.24		47.3	183	1.7	9.5	365	0.9	21.15		32.7	264	1.3	6.5	528	0.7	30.57		91.5	94	3.3	18.3	189	1.7	10.93	CMGV 042/15	31.1	370	2.7	6.2	740	1.4	32.13		CMGV 052/15		79.3	109	3.6	15.9	218			1.8	12.60		75.2	115	3.4			15.0	230	1.8	13.30		65.4			132	3.6	13.1	264	1.8	15.30				54.9	157	3.0	11.0	315			1.5	18.21		52.0	166	2.8		10.4	332	1.5	19.24		32.7	264	2.1	6.5	528	1.1	30.57		22.6	382	1.5	4.5	763	0.8	44.18		19.5	443	1.3	3.9	886	0.6	51.30		31.1	278	3.6	6.2	555	1.9	32.13	CMGV 052/15	21.6	534	1.9	4.3	1067		1.0	46.31		21.6	400		2.5	4.3	800	1.3	46.31			22.1	382	1.5	4.4		765	0.8	45.21	CMGV 043/15	17.8		632	1.6	3.6		1264		0.8	56.05	CMGV 053/15			16.3	519			1.1	3.3	1038			0.6	61.32				17.8	474	2.1			3.6	948	1.1		56.05		15.5		545	1.8	3.1	1091	0.9	64.48		13.3	634	1.6	2.7	1268	0.8	74.96		12.3	686	1.5	2.5	1372	0.8	81.07		11.6	730	1.4	2.3	1459	0.7	86.24		9.2	917	1.1	1.8	1835	0.6	108.43		11.6	730	1.4	2.3	1459	0.7	86.24		9.2	917	1.1	1.8	1835	0.6	108.43	2.2									2.2																		90L2 n ₁ =2800 [min ⁻¹]	534	32	4.1	107	86	2.0	3.74	CMGV 032/15																444	39		3.4	88.8	104	1.7	4.50											365	47	2.8	72.9	126	1.4	5.48											317	55	2.9	63.4	145	1.4	6.31											252	69	2.3	50.4	183	1.1	7.93											220	78	2.0	44.1	209	1.0	9.08											183	94	1.7	36.6	252	0.8	10.93											159	109	2.0	31.7	290	1.0	12.60											150	115	1.9	30.1	306	0.9	13.30											131	132	1.9	26.1	353	0.9	15.30											110	157	1.6	22.0	420	0.8	18.21											104	166	1.5	20.8	443	0.7	19.24											94.6	183	1.4	18.9	487	0.7	21.15											252	69	3.4	50.4	183	1.6	7.93	CMGV 042/15																	220	78	3.2	44.1	209	1.5	9.08											183	94	2.6	36.6	252	1.3	10.93											159	109	2.9	31.7	290	1.4	12.60											150	115	2.7	30.1	306	1.3	13.30											131	132	2.8	26.1	353	1.4	15.30											110	157	2.4	22.0	420	1.2	18.21											104	166	2.2	20.8	443	1.1	19.24											65.4	264	1.7	13.1	704	0.8	30.57											45.3	382	1.2	9.1	1018	0.6	44.18	1.5									1.5									90L4 n ₁ =1400 [min ⁻¹]	267	43	3.9	53.4	86	2.0	3.74	CMGV 032/15																	222	52	3.2	44.4	104	1.7	4.50		182	63	2.7	36.5	126	1.4	5.48		159	73	2.8	31.7	145	1.4	6.31		126	91	2.2	25.2	183	1.1	7.93		110	105	1.9	22.0	209	1.0	9.08		91.5	126	1.6	18.3	252	0.8	10.93		79.3	145	1.9	15.9	290	1.0	12.60		75.2	153	1.8	15.0	306	0.9	13.30		65.4	176	1.8	13.1	353	0.9	15.30		54.9	210	1.5	11.0	420	0.8	18.21		52.0	222	1.4	10.4	443	0.7	19.24		47.3	244	1.3	9.5	487	0.7	21.15
	75.2	115	2.4	15.0	230	1.3	13.30			65.4	132	2.4	13.1	264	1.2	15.30			54.9	157	2.0	11.0	315	1.0	18.21		52.0	166	1.9	10.4	332	1.0	19.24		47.3	183	1.7	9.5	365	0.9	21.15		32.7	264	1.3	6.5	528	0.7	30.57		91.5	94	3.3	18.3	189	1.7	10.93	CMGV 042/15	31.1	370	2.7	6.2	740	1.4	32.13		CMGV 052/15		79.3	109	3.6	15.9	218			1.8	12.60		75.2	115	3.4			15.0	230	1.8	13.30		65.4			132	3.6	13.1	264	1.8	15.30				54.9	157	3.0	11.0	315			1.5	18.21		52.0	166	2.8			10.4	332	1.5	19.24		32.7		264	2.1	6.5	528	1.1	30.57		22.6	382	1.5	4.5	763	0.8	44.18		19.5	443	1.3	3.9	886	0.6	51.30		31.1	278	3.6	6.2	555	1.9	32.13	CMGV 052/15	21.6	534	1.9	4.3	1067		1.0	46.31		21.6	400		2.5	4.3	800	1.3	46.31			22.1	382	1.5	4.4		765	0.8	45.21	CMGV 043/15	17.8		632	1.6	3.6		1264		0.8	56.05	CMGV 053/15				16.3	519			1.1	3.3	1038			0.6	61.32				17.8	474	2.1			3.6	948	1.1			56.05		15.5		545	1.8	3.1		1091	0.9	64.48		13.3	634	1.6	2.7	1268	0.8	74.96		12.3	686	1.5	2.5	1372	0.8	81.07		11.6	730	1.4	2.3	1459	0.7	86.24		9.2	917	1.1	1.8	1835	0.6	108.43		11.6	730	1.4	2.3	1459	0.7	86.24		9.2	917	1.1	1.8	1835	0.6	108.43	2.2									2.2																		90L2 n ₁ =2800 [min ⁻¹]	534	32	4.1	107	86	2.0	3.74	CMGV 032/15																444	39		3.4	88.8		104	1.7	4.50											365	47	2.8	72.9	126	1.4	5.48											317	55	2.9	63.4	145	1.4	6.31											252	69	2.3	50.4	183	1.1	7.93											220	78	2.0	44.1	209	1.0	9.08											183	94	1.7	36.6	252	0.8	10.93											159	109	2.0	31.7	290	1.0	12.60											150	115	1.9	30.1	306	0.9	13.30											131	132	1.9	26.1	353	0.9	15.30											110	157	1.6	22.0	420	0.8	18.21											104	166	1.5	20.8	443	0.7	19.24											94.6	183	1.4	18.9	487	0.7	21.15											252	69	3.4	50.4	183	1.6	7.93	CMGV 042/15																		220	78	3.2	44.1	209	1.5	9.08											183	94	2.6	36.6	252	1.3	10.93											159	109	2.9	31.7	290	1.4	12.60											150	115	2.7	30.1	306	1.3	13.30											131	132	2.8	26.1	353	1.4	15.30											110	157	2.4	22.0	420	1.2	18.21											104	166	2.2	20.8	443	1.1	19.24											65.4	264	1.7	13.1	704	0.8	30.57											45.3	382	1.2	9.1	1018	0.6	44.18	1.5									1.5									90L4 n ₁ =1400 [min ⁻¹]	267	43	3.9	53.4	86	2.0	3.74	CMGV 032/15																		222	52	3.2	44.4	104	1.7	4.50		182	63	2.7	36.5	126	1.4	5.48		159	73	2.8	31.7	145	1.4	6.31		126	91	2.2	25.2	183	1.1	7.93		110	105	1.9	22.0	209	1.0	9.08		91.5	126	1.6	18.3	252	0.8	10.93		79.3	145	1.9	15.9	290	1.0	12.60		75.2	153	1.8	15.0	306	0.9	13.30		65.4	176	1.8	13.1	353	0.9	15.30		54.9	210	1.5	11.0	420	0.8	18.21		52.0	222	1.4	10.4	443	0.7	19.24		47.3	244	1.3	9.5	487	0.7	21.15
	65.4	132	2.4	13.1	264	1.2	15.30			54.9	157	2.0	11.0	315	1.0	18.21			52.0	166	1.9	10.4	332	1.0	19.24		47.3	183	1.7	9.5	365	0.9	21.15		32.7	264	1.3	6.5	528	0.7	30.57		91.5	94	3.3	18.3	189	1.7	10.93	CMGV 042/15	31.1	370	2.7	6.2	740	1.4	32.13		CMGV 052/15		79.3	109	3.6	15.9	218			1.8	12.60		75.2	115	3.4			15.0	230	1.8	13.30		65.4			132	3.6	13.1	264	1.8	15.30				54.9	157	3.0	11.0	315			1.5	18.21		52.0	166	2.8			10.4	332	1.5	19.24		32.7			264	2.1	6.5	528	1.1	30.57			22.6	382	1.5	4.5	763	0.8	44.18		19.5	443	1.3	3.9	886	0.6	51.30		31.1	278	3.6	6.2	555	1.9	32.13	CMGV 052/15	21.6	534	1.9	4.3	1067		1.0	46.31		21.6	400		2.5	4.3	800	1.3	46.31			22.1	382	1.5	4.4		765	0.8	45.21	CMGV 043/15	17.8		632	1.6	3.6		1264		0.8	56.05	CMGV 053/15				16.3	519			1.1		3.3	1038			0.6	61.32				17.8	474	2.1			3.6	948	1.1			56.05		15.5			545	1.8	3.1		1091	0.9	64.48			13.3	634	1.6	2.7	1268	0.8	74.96		12.3	686	1.5	2.5	1372	0.8	81.07		11.6	730	1.4	2.3	1459	0.7	86.24		9.2	917	1.1	1.8	1835	0.6	108.43		11.6	730	1.4	2.3	1459	0.7	86.24		9.2	917	1.1	1.8	1835	0.6	108.43	2.2									2.2																		90L2 n ₁ =2800 [min ⁻¹]	534	32	4.1	107	86	2.0	3.74	CMGV 032/15																444	39		3.4	88.8		104	1.7		4.50											365	47	2.8	72.9	126	1.4	5.48											317	55	2.9	63.4	145	1.4	6.31											252	69	2.3	50.4	183	1.1	7.93											220	78	2.0	44.1	209	1.0	9.08											183	94	1.7	36.6	252	0.8	10.93											159	109	2.0	31.7	290	1.0	12.60											150	115	1.9	30.1	306	0.9	13.30											131	132	1.9	26.1	353	0.9	15.30											110	157	1.6	22.0	420	0.8	18.21											104	166	1.5	20.8	443	0.7	19.24											94.6	183	1.4	18.9	487	0.7	21.15											252	69	3.4	50.4	183	1.6	7.93	CMGV 042/15																			220	78	3.2	44.1	209	1.5	9.08											183	94	2.6	36.6	252	1.3	10.93											159	109	2.9	31.7	290	1.4	12.60											150	115	2.7	30.1	306	1.3	13.30											131	132	2.8	26.1	353	1.4	15.30											110	157	2.4	22.0	420	1.2	18.21											104	166	2.2	20.8	443	1.1	19.24											65.4	264	1.7	13.1	704	0.8	30.57											45.3	382	1.2	9.1	1018	0.6	44.18	1.5									1.5									90L4 n ₁ =1400 [min ⁻¹]	267	43	3.9	53.4	86	2.0	3.74	CMGV 032/15																			222	52	3.2	44.4	104	1.7	4.50		182	63	2.7	36.5	126	1.4	5.48		159	73	2.8	31.7	145	1.4	6.31		126	91	2.2	25.2	183	1.1	7.93		110	105	1.9	22.0	209	1.0	9.08		91.5	126	1.6	18.3	252	0.8	10.93		79.3	145	1.9	15.9	290	1.0	12.60		75.2	153	1.8	15.0	306	0.9	13.30		65.4	176	1.8	13.1	353	0.9	15.30		54.9	210	1.5	11.0	420	0.8	18.21		52.0	222	1.4	10.4	443	0.7	19.24		47.3	244	1.3	9.5	487	0.7	21.15
	54.9	157	2.0	11.0	315	1.0	18.21		52.0	166	1.9	10.4	332	1.0	19.24		47.3	183	1.7	9.5	365	0.9	21.15		32.7	264	1.3	6.5	528	0.7	30.57		91.5	94	3.3	18.3	189	1.7	10.93	CMGV 042/15	31.1	370	2.7	6.2	740	1.4	32.13	CMGV 052/15			79.3	109	3.6	15.9	218	1.8	12.60				75.2	115	3.4	15.0	230			1.8	13.30		65.4	132	3.6			13.1	264	1.8	15.30		54.9			157	3.0	11.0	315	1.5	18.21				52.0	166	2.8	10.4	332			1.5	19.24		32.7	264	2.1			6.5	528	1.1	30.57		22.6			382	1.5	4.5	763	0.8	44.18			19.5	443	1.3	3.9	886	0.6	51.30		31.1	278	3.6	6.2	555	1.9	32.13	CMGV 052/15	21.6	534	1.9	4.3	1067	1.0	46.31			21.6	400	2.5	4.3		800	1.3	46.31		22.1		382	1.5	4.4	765	0.8		45.21	CMGV 043/15	17.8	632	1.6		3.6	1264	0.8		56.05		CMGV 053/15		16.3		519		1.1	3.3			1038		0.6	61.32					17.8	474			2.1	3.6	948			1.1	56.05				15.5	545	1.8			3.1	1091	0.9			64.48		13.3		634	1.6	2.7		1268	0.8	74.96		12.3	686	1.5	2.5	1372	0.8	81.07		11.6	730	1.4	2.3	1459	0.7	86.24		9.2	917	1.1	1.8	1835	0.6	108.43		11.6	730	1.4	2.3	1459	0.7	86.24		9.2	917	1.1	1.8	1835	0.6	108.43	2.2									2.2																		90L2 n ₁ =2800 [min ⁻¹]	534	32	4.1	107	86	2.0	3.74	CMGV 032/15															444	39		3.4	88.8		104	1.7		4.50													365	47	2.8	72.9	126	1.4	5.48											317	55	2.9	63.4	145	1.4	6.31											252	69	2.3	50.4	183	1.1	7.93											220	78	2.0	44.1	209	1.0	9.08											183	94	1.7	36.6	252	0.8	10.93											159	109	2.0	31.7	290	1.0	12.60											150	115	1.9	30.1	306	0.9	13.30											131	132	1.9	26.1	353	0.9	15.30											110	157	1.6	22.0	420	0.8	18.21											104	166	1.5	20.8	443	0.7	19.24											94.6	183	1.4	18.9	487	0.7	21.15											252	69	3.4	50.4	183	1.6	7.93	CMGV 042/15																			220		78	3.2	44.1	209	1.5	9.08											183	94	2.6	36.6	252	1.3	10.93											159	109	2.9	31.7	290	1.4	12.60											150	115	2.7	30.1	306	1.3	13.30											131	132	2.8	26.1	353	1.4	15.30											110	157	2.4	22.0	420	1.2	18.21											104	166	2.2	20.8	443	1.1	19.24											65.4	264	1.7	13.1	704	0.8	30.57											45.3	382	1.2	9.1	1018	0.6	44.18	1.5									1.5									90L4 n ₁ =1400 [min ⁻¹]	267	43	3.9	53.4	86	2.0	3.74	CMGV 032/15																				222	52	3.2	44.4	104	1.7	4.50		182	63	2.7	36.5	126	1.4	5.48		159	73	2.8	31.7	145	1.4	6.31		126	91	2.2	25.2	183	1.1	7.93		110	105	1.9	22.0	209	1.0	9.08		91.5	126	1.6	18.3	252	0.8	10.93		79.3	145	1.9	15.9	290	1.0	12.60		75.2	153	1.8	15.0	306	0.9	13.30		65.4	176	1.8	13.1	353	0.9	15.30		54.9	210	1.5	11.0	420	0.8	18.21		52.0	222	1.4	10.4	443	0.7	19.24		47.3	244	1.3	9.5	487	0.7	21.15		
	52.0	166	1.9	10.4	332	1.0	19.24		47.3	183	1.7	9.5	365	0.9	21.15		32.7	264	1.3	6.5	528	0.7	30.57		91.5	94	3.3	18.3	189	1.7	10.93	CMGV 042/15	31.1	370	2.7	6.2	740	1.4	32.13		CMGV 052/15		79.3	109	3.6	15.9	218		1.8		12.60		75.2	115	3.4	15.0	230			1.8	13.30		65.4	132	3.6			13.1	264	1.8	15.30		54.9			157	3.0	11.0	315	1.5	18.21				52.0	166	2.8	10.4	332			1.5	19.24		32.7	264	2.1			6.5	528	1.1	30.57		22.6			382	1.5	4.5	763	0.8	44.18			19.5	443	1.3	3.9	886	0.6	51.30		31.1	278	3.6	6.2	555	1.9	32.13	CMGV 052/15	21.6	534	1.9	4.3	1067	1.0	46.31			21.6	400	2.5	4.3	800	1.3		46.31		22.1	382	1.5		4.4	765	0.8	45.21	CMGV 043/15		17.8	632	1.6	3.6	1264		0.8		56.05	CMGV 053/15			16.3	519	1.1		3.3			1038	0.6		61.32			17.8			474		2.1	3.6			948	1.1	56.05				15.5	545	1.8			3.1	1091	0.9			64.48		13.3			634	1.6	2.7		1268	0.8	74.96			12.3	686	1.5	2.5	1372	0.8	81.07		11.6	730	1.4	2.3	1459	0.7	86.24		9.2	917	1.1	1.8	1835	0.6	108.43		11.6	730	1.4	2.3	1459	0.7	86.24		9.2	917	1.1	1.8	1835	0.6	108.43	2.2									2.2																		90L2 n ₁ =2800 [min ⁻¹]	534	32	4.1	107	86	2.0	3.74	CMGV 032/15												444		39	3.4		88.8	104		1.7	4.50																365	47	2.8	72.9	126	1.4	5.48											317	55	2.9	63.4	145	1.4	6.31											252	69	2.3	50.4	183	1.1	7.93											220	78	2.0	44.1	209	1.0	9.08											183	94	1.7	36.6	252	0.8	10.93											159	109	2.0	31.7	290	1.0	12.60											150	115	1.9	30.1	306	0.9	13.30											131	132	1.9	26.1	353	0.9	15.30											110	157	1.6	22.0	420	0.8	18.21											104	166	1.5	20.8	443	0.7	19.24											94.6	183	1.4	18.9	487	0.7	21.15											252	69	3.4	50.4	183	1.6	7.93	CMGV 042/15													220		78		3.2		44.1		209		1.5		9.08												183	94	2.6	36.6	252	1.3	10.93											159	109	2.9	31.7	290	1.4	12.60											150	115	2.7	30.1	306	1.3	13.30											131	132	2.8	26.1	353	1.4	15.30											110	157	2.4	22.0	420	1.2	18.21											104	166	2.2	20.8	443	1.1	19.24											65.4	264	1.7	13.1	704	0.8	30.57											45.3	382	1.2	9.1	1018	0.6	44.18	1.5									1.5									90L4 n ₁ =1400 [min ⁻¹]	267	43	3.9	53.4	86	2.0	3.74	CMGV 032/15																				222	52	3.2	44.4	104	1.7	4.50		182	63	2.7	36.5	126	1.4	5.48		159	73	2.8	31.7	145	1.4	6.31		126	91	2.2	25.2	183	1.1	7.93		110	105	1.9	22.0	209	1.0	9.08		91.5	126	1.6	18.3	252	0.8	10.93		79.3	145	1.9	15.9	290	1.0	12.60		75.2	153	1.8	15.0	306	0.9	13.30		65.4	176	1.8	13.1	353	0.9	15.30		54.9	210	1.5	11.0	420	0.8	18.21		52.0	222	1.4	10.4	443	0.7	19.24		47.3	244	1.3	9.5	487	0.7	21.15										
	47.3	183	1.7	9.5	365	0.9	21.15		32.7	264	1.3	6.5	528	0.7	30.57		91.5	94	3.3	18.3	189	1.7	10.93	CMGV 042/15	31.1	370	2.7	6.2	740	1.4	32.13		CMGV 052/15		79.3	109	3.6	15.9	218			1.8	12.60		75.2	115	3.4		15.0		230	1.8	13.30		65.4	132	3.6			13.1	264	1.8	15.30		54.9			157	3.0	11.0	315	1.5	18.21				52.0	166	2.8	10.4	332			1.5	19.24		32.7	264	2.1			6.5	528	1.1	30.57		22.6			382	1.5	4.5	763	0.8	44.18			19.5	443	1.3	3.9	886	0.6	51.30		31.1	278	3.6	6.2	555	1.9	32.13	CMGV 052/15	21.6	534	1.9	4.3	1067	1.0	46.31			21.6	400	2.5	4.3	800	1.3		46.31		22.1	382	1.5	4.4	765		0.8	45.21	CMGV 043/15	17.8	632		1.6	3.6	1264	0.8			56.05	CMGV 053/15		16.3	519		1.1		3.3		1038		0.6	61.32			17.8			474	2.1		3.6		948	1.1			56.05		15.5	545			1.8	3.1	1091	0.9			64.48		13.3			634	1.6	2.7			1268	0.8	74.96			12.3	686	1.5		2.5	1372	0.8	81.07		11.6	730	1.4	2.3	1459	0.7	86.24		9.2	917	1.1	1.8	1835	0.6	108.43		11.6	730	1.4	2.3	1459	0.7	86.24		9.2	917	1.1	1.8	1835	0.6	108.43	2.2									2.2																		90L2 n ₁ =2800 [min ⁻¹]	534	32	4.1	107	86	2.0	3.74	CMGV 032/15												444	39	3.4	88.8		104	1.7	4.50																365		47	2.8		72.9	126	1.4	5.48											317	55	2.9	63.4	145	1.4	6.31											252	69	2.3	50.4	183	1.1	7.93											220	78	2.0	44.1	209	1.0	9.08											183	94	1.7	36.6	252	0.8	10.93											159	109	2.0	31.7	290	1.0	12.60											150	115	1.9	30.1	306	0.9	13.30											131	132	1.9	26.1	353	0.9	15.30											110	157	1.6	22.0	420	0.8	18.21											104	166	1.5	20.8	443	0.7	19.24											94.6	183	1.4	18.9	487	0.7	21.15											252	69	3.4	50.4	183	1.6	7.93	CMGV 042/15												220	78	3.2	44.1		209	1.5	9.08																		183	94	2.6	36.6	252	1.3	10.93											159	109	2.9	31.7	290	1.4	12.60											150	115	2.7	30.1	306	1.3	13.30											131	132	2.8	26.1	353	1.4	15.30											110	157	2.4	22.0	420	1.2	18.21											104	166	2.2	20.8	443	1.1	19.24											65.4	264	1.7	13.1	704	0.8	30.57											45.3	382	1.2	9.1	1018	0.6	44.18	1.5									1.5									90L4 n ₁ =1400 [min ⁻¹]	267	43	3.9	53.4	86	2.0	3.74	CMGV 032/15												222	52	3.2	44.4		104	1.7								4.50		182	63	2.7	36.5	126	1.4	5.48		159	73	2.8	31.7	145	1.4	6.31		126	91	2.2	25.2	183	1.1	7.93		110	105	1.9	22.0	209	1.0	9.08		91.5	126	1.6	18.3	252	0.8	10.93		79.3	145	1.9	15.9	290	1.0	12.60		75.2	153	1.8	15.0	306	0.9	13.30		65.4	176	1.8	13.1	353	0.9	15.30		54.9	210	1.5	11.0	420	0.8	18.21		52.0	222	1.4	10.4	443	0.7	19.24		47.3	244	1.3	9.5	487	0.7	21.15																		
	32.7	264	1.3	6.5	528	0.7	30.57		91.5	94	3.3	18.3	189	1.7	10.93	CMGV 042/15	31.1	370	2.7	6.2	740	1.4	32.13		CMGV 052/15		79.3	109	3.6	15.9	218			1.8	12.60		75.2	115	3.4			15.0	230	1.8	13.30		65.4		132		3.6	13.1	264	1.8	15.30		54.9			157	3.0	11.0	315	1.5	18.21				52.0	166	2.8	10.4	332			1.5	19.24		32.7	264	2.1			6.5	528	1.1	30.57		22.6			382	1.5	4.5	763	0.8	44.18			19.5	443	1.3	3.9	886	0.6	51.30		31.1	278	3.6	6.2	555	1.9	32.13	CMGV 052/15	21.6	534	1.9	4.3	1067	1.0	46.31			21.6	400	2.5	4.3	800	1.3		46.31		22.1	382	1.5	4.4	765		0.8	45.21	CMGV 043/15	17.8	632	1.6	3.6		1264	0.8		56.05	CMGV 053/15			16.3	519	1.1			3.3		1038	0.6	61.32				17.8		474		2.1	3.6	948		1.1			56.05			15.5	545	1.8	3.1			1091	0.9	64.48				13.3	634	1.6	2.7			1268	0.8	74.96				12.3	686		1.5	2.5	1372	0.8		81.07		11.6	730	1.4	2.3	1459	0.7	86.24		9.2	917	1.1	1.8	1835	0.6	108.43		11.6	730	1.4	2.3	1459	0.7	86.24		9.2	917	1.1	1.8	1835	0.6	108.43	2.2									2.2																		90L2 n ₁ =2800 [min ⁻¹]	534	32	4.1	107	86	2.0	3.74	CMGV 032/15												444	39	3.4	88.8		104	1.7	4.50														365	47		2.8	72.9		126	1.4		5.48												317	55	2.9	63.4	145	1.4	6.31											252	69	2.3	50.4	183	1.1	7.93											220	78	2.0	44.1	209	1.0	9.08											183	94	1.7	36.6	252	0.8	10.93											159	109	2.0	31.7	290	1.0	12.60											150	115	1.9	30.1	306	0.9	13.30											131	132	1.9	26.1	353	0.9	15.30											110	157	1.6	22.0	420	0.8	18.21											104	166	1.5	20.8	443	0.7	19.24											94.6	183	1.4	18.9	487	0.7	21.15											252	69	3.4	50.4	183	1.6	7.93	CMGV 042/15												220	78	3.2	44.1		209	1.5	9.08																183		94		2.6	36.6	252	1.3	10.93											159	109	2.9	31.7	290	1.4	12.60											150	115	2.7	30.1	306	1.3	13.30											131	132	2.8	26.1	353	1.4	15.30											110	157	2.4	22.0	420	1.2	18.21											104	166	2.2	20.8	443	1.1	19.24											65.4	264	1.7	13.1	704	0.8	30.57											45.3	382	1.2	9.1	1018	0.6	44.18	1.5									1.5									90L4 n ₁ =1400 [min ⁻¹]	267	43	3.9	53.4	86	2.0	3.74	CMGV 032/15												222	52	3.2	44.4		104	1.7	4.50		182	63	2.7		36.5	126							1.4	5.48		159	73	2.8	31.7	145	1.4	6.31		126	91	2.2	25.2	183	1.1	7.93		110	105	1.9	22.0	209	1.0	9.08		91.5	126	1.6	18.3	252	0.8	10.93		79.3	145	1.9	15.9	290	1.0	12.60		75.2	153	1.8	15.0	306	0.9	13.30		65.4	176	1.8	13.1	353	0.9	15.30		54.9	210	1.5	11.0	420	0.8	18.21		52.0	222	1.4	10.4	443	0.7	19.24		47.3	244	1.3	9.5	487	0.7	21.15																										
	91.5	94	3.3	18.3	189	1.7	10.93	CMGV 042/15	31.1	370	2.7	6.2	740	1.4	32.13		CMGV 052/15																																																																																																																																																																																																																																																																																																																																																																																																																																																																																																																																																																																																																																																																																																																																																																																																																																																									
	79.3	109	3.6	15.9	218	1.8	12.60			75.2	115	3.4	15.0	230	1.8			13.30		65.4	132	3.6	13.1			264	1.8	15.30		54.9	157			3.0	11.0	315	1.5	18.21				52.0	166	2.8	10.4	332	1.5		19.24			32.7	264	2.1	6.5	528	1.1			30.57		22.6	382	1.5	4.5			763	0.8	44.18		19.5	443			1.3	3.9	886	0.6	51.30		31.1		278	3.6	6.2	555	1.9	32.13	CMGV 052/15	21.6	534	1.9	4.3	1067	1.0	46.31		21.6	400	2.5	4.3	800	1.3	46.31		22.1	382	1.5	4.4	765	0.8	45.21	CMGV 043/15		17.8	632	1.6	3.6	1264	0.8	56.05		CMGV 053/15		16.3	519	1.1	3.3	1038		0.6	61.32		17.8	474	2.1	3.6		948	1.1		56.05		15.5	545		1.8	3.1		1091			0.9	64.48		13.3			634		1.6	2.7	1268		0.8		74.96			12.3	686	1.5	2.5		1372	0.8		81.07			11.6	730	1.4	2.3			1459	0.7	86.24				9.2	917	1.1	1.8		1835	0.6	108.43			11.6	730	1.4	2.3	1459	0.7	86.24		9.2	917	1.1	1.8	1835	0.6	108.43	2.2									2.2																		90L2 n ₁ =2800 [min ⁻¹]	534	32	4.1	107	86	2.0	3.74	CMGV 032/15											444	39	3.4	88.8	104	1.7	4.50												365	47	2.8	72.9	126	1.4	5.48													317	55	2.9	63.4		145	1.4	6.31															252	69	2.3	50.4	183	1.1	7.93											220	78	2.0	44.1	209	1.0	9.08											183	94	1.7	36.6	252	0.8	10.93											159	109	2.0	31.7	290	1.0	12.60											150	115	1.9	30.1	306	0.9	13.30											131	132	1.9	26.1	353	0.9	15.30											110	157	1.6	22.0	420	0.8	18.21											104	166	1.5	20.8	443	0.7	19.24											94.6	183	1.4	18.9	487	0.7	21.15											252	69	3.4	50.4	183	1.6	7.93	CMGV 042/15											220	78	3.2	44.1	209	1.5	9.08											183		94	2.6	36.6	252	1.3	10.93													159	109	2.9	31.7	290		1.4	12.60															150	115	2.7	30.1	306	1.3	13.30											131	132	2.8	26.1	353	1.4	15.30											110	157	2.4	22.0	420	1.2	18.21											104	166	2.2	20.8	443	1.1	19.24											65.4	264	1.7	13.1	704	0.8	30.57											45.3	382	1.2	9.1	1018	0.6	44.18	1.5									1.5									90L4 n ₁ =1400 [min ⁻¹]	267	43	3.9	53.4	86	2.0	3.74	CMGV 032/15											222	52	3.2	44.4	104	1.7	4.50		182	63	2.7	36.5	126	1.4	5.48		159	73	2.8		31.7	145	1.4	6.31		126	91		2.2	25.2	183	1.1	7.93		110		105	1.9	22.0	209	1.0	9.08			91.5	126					1.6	18.3	252	0.8	10.93		79.3	145	1.9	15.9	290	1.0	12.60		75.2	153	1.8	15.0	306	0.9	13.30		65.4	176	1.8	13.1	353	0.9	15.30		54.9	210	1.5	11.0	420	0.8	18.21		52.0	222	1.4	10.4	443	0.7	19.24		47.3	244	1.3	9.5	487	0.7	21.15																																																									
	75.2	115	3.4	15.0	230	1.8	13.30			65.4	132	3.6	13.1	264	1.8			15.30		54.9	157	3.0	11.0			315	1.5	18.21		52.0	166			2.8	10.4	332	1.5	19.24				32.7	264	2.1	6.5	528	1.1		30.57			22.6	382	1.5	4.5	763	0.8			44.18		19.5	443	1.3	3.9			886	0.6	51.30		31.1	278	3.6		6.2	555	1.9	32.13	CMGV 052/15	21.6	534	1.9	4.3	1067	1.0	46.31		21.6		400	2.5	4.3	800	1.3	46.31		22.1	382	1.5	4.4	765	0.8	45.21	CMGV 043/15	17.8	632	1.6	3.6	1264	0.8	56.05	CMGV 053/15				16.3	519	1.1	3.3	1038	0.6			61.32		17.8	474	2.1	3.6		948	1.1	56.05		15.5	545	1.8		3.1	1091		0.9	64.48		13.3		634	1.6		2.7			1268	0.8	74.96				12.3		686	1.5	2.5	1372	0.8		81.07			11.6	730	1.4	2.3		1459	0.7		86.24			9.2	917	1.1	1.8			1835	0.6	108.43			11.6	730	1.4	2.3	1459		0.7	86.24		9.2	917	1.1	1.8	1835	0.6	108.43	2.2									2.2																		90L2 n ₁ =2800 [min ⁻¹]	534	32	4.1	107	86	2.0	3.74	CMGV 032/15												444	39	3.4	88.8	104	1.7	4.50											365	47	2.8	72.9	126	1.4	5.48													317	55	2.9	63.4	145	1.4		6.31													252	69		2.3	50.4		183	1.1	7.93											220	78	2.0	44.1	209	1.0	9.08											183	94	1.7	36.6	252	0.8	10.93											159	109	2.0	31.7	290	1.0	12.60											150	115	1.9	30.1	306	0.9	13.30											131	132	1.9	26.1	353	0.9	15.30											110	157	1.6	22.0	420	0.8	18.21											104	166	1.5	20.8	443	0.7	19.24											94.6	183	1.4	18.9	487	0.7	21.15											252	69	3.4	50.4	183	1.6	7.93	CMGV 042/15												220	78	3.2	44.1	209	1.5	9.08											183	94	2.6	36.6	252	1.3	10.93													159	109	2.9	31.7	290	1.4	12.60														150		115		2.7	30.1	306	1.3	13.30											131	132	2.8	26.1	353	1.4	15.30											110	157	2.4	22.0	420	1.2	18.21											104	166	2.2	20.8	443	1.1	19.24											65.4	264	1.7	13.1	704	0.8	30.57											45.3	382	1.2	9.1	1018	0.6	44.18	1.5									1.5									90L4 n ₁ =1400 [min ⁻¹]	267	43	3.9	53.4	86	2.0	3.74	CMGV 032/15												222	52	3.2	44.4	104	1.7	4.50		182	63	2.7	36.5	126	1.4	5.48		159	73	2.8	31.7	145	1.4	6.31		126	91	2.2	25.2		183	1.1	7.93		110	105	1.9		22.0	209	1.0	9.08		91.5	126		1.6	18.3	252	0.8	10.93		79.3		145	1.9				15.9	290	1.0	12.60		75.2	153	1.8	15.0	306	0.9	13.30		65.4	176	1.8	13.1	353	0.9	15.30		54.9	210	1.5	11.0	420	0.8	18.21		52.0	222	1.4	10.4	443	0.7	19.24		47.3	244	1.3	9.5	487	0.7	21.15																																																																			
	65.4	132	3.6	13.1	264	1.8	15.30			54.9	157	3.0	11.0	315	1.5			18.21		52.0	166	2.8	10.4			332	1.5	19.24		32.7	264			2.1	6.5	528	1.1	30.57				22.6	382	1.5	4.5	763	0.8		44.18			19.5	443	1.3	3.9	886	0.6			51.30		31.1	278	3.6	6.2	555		1.9	32.13	CMGV 052/15	21.6	534	1.9	4.3	1067	1.0	46.31		21.6		400	2.5	4.3	800	1.3	46.31		22.1	382		1.5	4.4	765	0.8	45.21	CMGV 043/15	17.8	632	1.6	3.6	1264	0.8	56.05	CMGV 053/15			16.3	519	1.1	3.3	1038	0.6				61.32		17.8	474	2.1	3.6	948			1.1	56.05		15.5	545	1.8		3.1	1091	0.9	64.48		13.3	634		1.6	2.7		1268	0.8	74.96			12.3	686		1.5			2.5	1372	0.8	81.07			11.6		730	1.4	2.3	1459	0.7		86.24			9.2	917	1.1	1.8		1835	0.6		108.43			11.6	730	1.4	2.3		1459	0.7	86.24		9.2		917	1.1	1.8	1835	0.6	108.43	2.2									2.2																		90L2 n ₁ =2800 [min ⁻¹]	534	32	4.1	107	86	2.0	3.74	CMGV 032/15												444	39	3.4	88.8	104	1.7	4.50												365	47	2.8	72.9	126	1.4	5.48											317		55	2.9	63.4	145	1.4	6.31													252	69	2.3	50.4	183		1.1	7.93													220	78	2.0	44.1	209	1.0	9.08											183	94	1.7	36.6	252	0.8	10.93											159	109	2.0	31.7	290	1.0	12.60											150	115	1.9	30.1	306	0.9	13.30											131	132	1.9	26.1	353	0.9	15.30											110	157	1.6	22.0	420	0.8	18.21											104	166	1.5	20.8	443	0.7	19.24											94.6	183	1.4	18.9	487	0.7	21.15											252	69	3.4	50.4	183	1.6	7.93	CMGV 042/15												220	78	3.2	44.1	209	1.5	9.08												183	94	2.6	36.6	252	1.3	10.93											159	109		2.9	31.7	290	1.4	12.60													150	115	2.7	30.1	306	1.3		13.30													131	132	2.8	26.1	353	1.4	15.30											110	157	2.4	22.0	420	1.2	18.21											104	166	2.2	20.8	443	1.1	19.24											65.4	264	1.7	13.1	704	0.8	30.57											45.3	382	1.2	9.1	1018	0.6	44.18	1.5									1.5									90L4 n ₁ =1400 [min ⁻¹]	267	43	3.9	53.4	86	2.0	3.74	CMGV 032/15												222	52	3.2	44.4	104	1.7	4.50			182	63	2.7	36.5	126	1.4	5.48		159	73	2.8	31.7	145	1.4	6.31		126	91	2.2	25.2	183	1.1	7.93		110	105	1.9	22.0	209		1.0	9.08		91.5	126	1.6	18.3		252	0.8	10.93		79.3	145	1.9		15.9	290	1.0	12.60		75.2	153		1.8	15.0			306	0.9	13.30		65.4	176	1.8	13.1	353	0.9	15.30		54.9	210	1.5	11.0	420	0.8	18.21		52.0	222	1.4	10.4	443	0.7	19.24		47.3	244	1.3	9.5	487	0.7	21.15																																																																													
	54.9	157	3.0	11.0	315	1.5	18.21			52.0	166	2.8	10.4	332	1.5			19.24		32.7	264	2.1	6.5			528	1.1	30.57		22.6	382			1.5	4.5	763	0.8	44.18				19.5	443	1.3	3.9	886	0.6		51.30			31.1	278	3.6	6.2	555	1.9	32.13		CMGV 052/15	21.6	534	1.9	4.3	1067	1.0	46.31		21.6		400	2.5	4.3	800	1.3	46.31		22.1	382		1.5	4.4	765	0.8	45.21	CMGV 043/15	17.8	632	1.6		3.6	1264	0.8	56.05	CMGV 053/15			16.3	519	1.1	3.3	1038	0.6			61.32		17.8	474	2.1	3.6	948				1.1	56.05		15.5	545	1.8	3.1			1091	0.9	64.48		13.3	634		1.6	2.7	1268	0.8	74.96		12.3		686	1.5		2.5	1372	0.8	81.07			11.6		730		1.4	2.3	1459	0.7	86.24			9.2		917	1.1	1.8	1835	0.6		108.43			11.6	730	1.4	2.3		1459	0.7		86.24		9.2	917	1.1	1.8	1835		0.6	108.43	2.2									2.2																		90L2 n ₁ =2800 [min ⁻¹]	534	32	4.1	107	86	2.0	3.74	CMGV 032/15												444	39	3.4	88.8	104	1.7	4.50													365	47	2.8	72.9	126	1.4	5.48											317	55	2.9	63.4	145	1.4	6.31													252	69	2.3	50.4	183	1.1	7.93													220		78	2.0	44.1	209	1.0	9.08											183	94	1.7	36.6	252	0.8	10.93											159	109	2.0	31.7	290	1.0	12.60											150	115	1.9	30.1	306	0.9	13.30											131	132	1.9	26.1	353	0.9	15.30											110	157	1.6	22.0	420	0.8	18.21											104	166	1.5	20.8	443	0.7	19.24											94.6	183	1.4	18.9	487	0.7	21.15											252	69	3.4	50.4	183	1.6	7.93	CMGV 042/15												220	78	3.2	44.1	209	1.5	9.08													183	94	2.6	36.6	252	1.3	10.93											159	109	2.9	31.7	290	1.4	12.60												150		115	2.7	30.1	306	1.3	13.30													131		132	2.8	26.1	353	1.4	15.30											110	157	2.4	22.0	420	1.2	18.21											104	166	2.2	20.8	443	1.1	19.24											65.4	264	1.7	13.1	704	0.8	30.57											45.3	382	1.2	9.1	1018	0.6	44.18	1.5									1.5									90L4 n ₁ =1400 [min ⁻¹]	267	43	3.9	53.4	86	2.0	3.74	CMGV 032/15												222	52	3.2	44.4	104	1.7	4.50			182	63	2.7	36.5	126	1.4	5.48		159		73	2.8	31.7	145	1.4	6.31		126	91	2.2	25.2	183	1.1	7.93		110	105	1.9	22.0	209	1.0	9.08		91.5	126	1.6	18.3	252	0.8		10.93		79.3	145	1.9	15.9	290		1.0	12.60		75.2	153	1.8	15.0		306	0.9	13.30		65.4	176	1.8		13.1	353		0.9	15.30		54.9	210	1.5	11.0	420	0.8	18.21		52.0	222	1.4	10.4	443	0.7	19.24		47.3	244	1.3	9.5	487	0.7	21.15																																																																																							
	52.0	166	2.8	10.4	332	1.5	19.24			32.7	264	2.1	6.5	528	1.1			30.57		22.6	382	1.5	4.5			763	0.8	44.18		19.5	443			1.3	3.9	886	0.6	51.30				31.1	278	3.6	6.2	555	1.9		32.13	CMGV 052/15	21.6	534	1.9	4.3	1067	1.0	46.31		21.6		400	2.5	4.3	800	1.3	46.31		22.1	382		1.5	4.4	765	0.8	45.21	CMGV 043/15	17.8	632	1.6		3.6	1264	0.8	56.05	CMGV 053/15			16.3	519		1.1	3.3	1038	0.6			61.32		17.8	474	2.1	3.6	948			1.1	56.05		15.5	545	1.8	3.1				1091	0.9	64.48		13.3	634	1.6			2.7	1268	0.8	74.96		12.3		686	1.5	2.5	1372	0.8	81.07			11.6	730		1.4	2.3	1459	0.7	86.24		9.2		917		1.1	1.8	1835	0.6	108.43			11.6		730	1.4	2.3	1459	0.7		86.24			9.2	917	1.1	1.8	1835	0.6	108.43		2.2									2.2																		90L2 n ₁ =2800 [min ⁻¹]	534	32	4.1	107	86	2.0	3.74	CMGV 032/15												444	39	3.4	88.8	104	1.7	4.50													365	47	2.8	72.9	126	1.4	5.48												317	55	2.9	63.4	145	1.4	6.31											252	69		2.3	50.4	183	1.1	7.93													220	78	2.0	44.1	209	1.0		9.08											183	94	1.7	36.6	252	0.8	10.93											159	109	2.0	31.7	290	1.0	12.60											150	115	1.9	30.1	306	0.9	13.30											131	132	1.9	26.1	353	0.9	15.30											110	157	1.6	22.0	420	0.8	18.21											104	166	1.5	20.8	443	0.7	19.24											94.6	183	1.4	18.9	487	0.7	21.15											252	69	3.4	50.4	183	1.6	7.93	CMGV 042/15												220	78	3.2	44.1	209	1.5	9.08													183	94	2.6	36.6	252	1.3	10.93												159	109	2.9	31.7	290	1.4	12.60											150	115	2.7		30.1	306	1.3	13.30													131	132	2.8	26.1	353	1.4	15.30												110	157	2.4	22.0	420	1.2	18.21											104	166	2.2	20.8	443	1.1	19.24											65.4	264	1.7	13.1	704	0.8	30.57											45.3	382	1.2	9.1	1018	0.6	44.18	1.5									1.5									90L4 n ₁ =1400 [min ⁻¹]	267	43	3.9	53.4	86	2.0	3.74	CMGV 032/15												222	52	3.2	44.4	104	1.7	4.50			182	63	2.7	36.5	126	1.4	5.48		159		73	2.8	31.7	145	1.4	6.31		126	91		2.2	25.2	183	1.1	7.93		110	105	1.9	22.0	209	1.0	9.08		91.5	126	1.6	18.3	252	0.8	10.93		79.3	145	1.9	15.9	290	1.0	12.60			75.2	153	1.8	15.0	306	0.9		13.30		65.4	176	1.8	13.1	353		0.9	15.30		54.9	210	1.5	11.0		420	0.8	18.21		52.0	222	1.4	10.4	443	0.7	19.24		47.3	244	1.3	9.5	487	0.7	21.15																																																																																																	
	32.7	264	2.1	6.5	528	1.1	30.57			22.6	382	1.5	4.5	763	0.8			44.18		19.5	443	1.3	3.9			886	0.6	51.30		31.1	278			3.6	6.2	555	1.9	32.13	CMGV 052/15	21.6		534	1.9	4.3	1067	1.0	46.31		21.6		400	2.5	4.3	800	1.3	46.31		22.1	382		1.5	4.4	765	0.8	45.21	CMGV 043/15	17.8	632	1.6		3.6	1264	0.8	56.05	CMGV 053/15			16.3	519		1.1	3.3	1038	0.6			61.32		17.8		474	2.1	3.6	948			1.1	56.05		15.5	545	1.8	3.1			1091	0.9	64.48		13.3	634	1.6				2.7	1268	0.8	74.96		12.3	686			1.5	2.5	1372	0.8	81.07			11.6	730	1.4	2.3	1459	0.7	86.24		9.2	917		1.1	1.8	1835	0.6	108.43		11.6		730		1.4	2.3	1459	0.7	86.24			9.2		917	1.1	1.8	1835	0.6	108.43	2.2									2.2																		90L2 n ₁ =2800 [min ⁻¹]	534	32	4.1	107	86	2.0	3.74	CMGV 032/15												444	39	3.4	88.8	104	1.7	4.50												365		47	2.8	72.9	126	1.4	5.48												317	55		2.9	63.4	145	1.4	6.31											252	69	2.3	50.4	183	1.1	7.93												220	78		2.0	44.1	209	1.0	9.08												183	94	1.7	36.6	252	0.8	10.93											159	109	2.0	31.7	290	1.0	12.60											150	115	1.9	30.1	306	0.9	13.30											131	132	1.9	26.1	353	0.9	15.30											110	157	1.6	22.0	420	0.8	18.21											104	166	1.5	20.8	443	0.7	19.24											94.6	183	1.4	18.9	487	0.7	21.15											252	69	3.4	50.4	183	1.6	7.93	CMGV 042/15												220	78	3.2	44.1	209	1.5	9.08												183		94	2.6	36.6	252	1.3	10.93												159	109		2.9	31.7	290	1.4	12.60											150	115	2.7	30.1	306	1.3	13.30												131	132	2.8		26.1	353	1.4	15.30												110	157	2.4	22.0	420	1.2	18.21											104	166	2.2	20.8	443	1.1	19.24											65.4	264	1.7	13.1	704	0.8	30.57											45.3	382	1.2	9.1	1018	0.6	44.18	1.5									1.5									90L4 n ₁ =1400 [min ⁻¹]	267	43	3.9	53.4	86	2.0	3.74	CMGV 032/15												222	52	3.2	44.4	104	1.7	4.50		182		63	2.7	36.5	126	1.4	5.48		159	73		2.8	31.7	145	1.4	6.31		126	91	2.2		25.2	183	1.1	7.93		110	105	1.9	22.0		209	1.0	9.08		91.5	126	1.6	18.3	252	0.8	10.93		79.3	145	1.9	15.9	290	1.0	12.60		75.2	153	1.8	15.0	306	0.9	13.30		65.4		176	1.8	13.1	353	0.9	15.30			54.9	210	1.5	11.0	420	0.8	18.21			52.0	222	1.4	10.4	443	0.7	19.24		47.3	244	1.3	9.5	487	0.7	21.15																																																																																																												
	22.6	382	1.5	4.5	763	0.8	44.18			19.5	443	1.3	3.9	886	0.6			51.30		31.1	278	3.6	6.2			555	1.9	32.13	CMGV 052/15	21.6	534	1.9		4.3	1067	1.0	46.31			21.6	400	2.5	4.3	800	1.3	46.31		22.1	382		1.5	4.4	765	0.8	45.21	CMGV 043/15	17.8	632	1.6		3.6	1264	0.8	56.05	CMGV 053/15			16.3	519		1.1	3.3	1038	0.6			61.32		17.8		474	2.1	3.6	948			1.1	56.05			15.5	545	1.8	3.1			1091	0.9	64.48		13.3	634	1.6			2.7	1268	0.8	74.96		12.3	686				1.5	2.5	1372	0.8	81.07		11.6			730	1.4	2.3	1459	0.7	86.24		9.2	917	1.1	1.8	1835	0.6	108.43		11.6	730		1.4	2.3	1459	0.7	86.24		9.2		917		1.1	1.8	1835	0.6	108.43	2.2									2.2																		90L2 n ₁ =2800 [min ⁻¹]	534	32	4.1	107	86	2.0	3.74	CMGV 032/15												444	39	3.4	88.8	104	1.7	4.50												365		47	2.8	72.9	126	1.4	5.48												317	55		2.9	63.4	145	1.4	6.31												252	69	2.3	50.4	183	1.1	7.93											220	78	2.0	44.1		209	1.0	9.08												183	94	1.7	36.6	252	0.8	10.93											159	109	2.0	31.7	290	1.0	12.60											150	115	1.9	30.1	306	0.9	13.30											131	132	1.9	26.1	353	0.9	15.30											110	157	1.6	22.0	420	0.8	18.21											104	166	1.5	20.8	443	0.7	19.24											94.6	183	1.4	18.9	487	0.7	21.15											252	69	3.4	50.4	183	1.6	7.93	CMGV 042/15												220	78	3.2	44.1	209	1.5	9.08												183		94	2.6	36.6	252	1.3	10.93												159	109		2.9	31.7	290	1.4	12.60												150	115	2.7	30.1	306	1.3	13.30											131	132	2.8	26.1	353		1.4	15.30												110	157	2.4	22.0	420	1.2	18.21											104	166	2.2	20.8	443	1.1	19.24											65.4	264	1.7	13.1	704	0.8	30.57											45.3	382	1.2	9.1	1018	0.6	44.18	1.5									1.5									90L4 n ₁ =1400 [min ⁻¹]	267	43	3.9	53.4	86	2.0	3.74	CMGV 032/15												222	52	3.2	44.4	104	1.7	4.50		182		63	2.7	36.5	126	1.4	5.48		159	73		2.8	31.7	145	1.4	6.31		126	91	2.2		25.2	183	1.1	7.93		110	105	1.9	22.0		209	1.0	9.08		91.5	126	1.6	18.3	252		0.8	10.93		79.3	145	1.9	15.9	290	1.0	12.60		75.2	153	1.8	15.0	306	0.9	13.30		65.4	176	1.8	13.1	353	0.9	15.30		54.9	210		1.5	11.0	420	0.8	18.21		52.0		222	1.4	10.4	443	0.7	19.24		47.3	244	1.3	9.5	487	0.7	21.15																																																																																																																						
	19.5	443	1.3	3.9	886	0.6	51.30			31.1	278	3.6	6.2	555	1.9			32.13	CMGV 052/15	21.6	534	1.9	4.3	1067		1.0	46.31			21.6	400	2.5	4.3	800	1.3	46.31		22.1		382	1.5	4.4	765	0.8	45.21	CMGV 043/15	17.8	632	1.6		3.6	1264	0.8	56.05	CMGV 053/15			16.3	519		1.1	3.3	1038	0.6			61.32		17.8		474	2.1	3.6	948			1.1	56.05			15.5	545	1.8	3.1			1091	0.9	64.48			13.3	634	1.6			2.7	1268	0.8	74.96		12.3	686			1.5	2.5	1372	0.8	81.07		11.6				730	1.4	2.3	1459	0.7	86.24		9.2		917	1.1	1.8	1835	0.6	108.43		11.6	730	1.4	2.3	1459	0.7	86.24		9.2	917		1.1	1.8	1835	0.6	108.43	2.2									2.2																		90L2 n ₁ =2800 [min ⁻¹]	534	32	4.1	107	86	2.0	3.74	CMGV 032/15												444	39	3.4	88.8	104	1.7	4.50												365		47	2.8	72.9	126	1.4	5.48												317	55		2.9	63.4	145	1.4	6.31												252	69	2.3		50.4	183	1.1	7.93											220	78	2.0	44.1	209	1.0	9.08												183	94	1.7	36.6	252	0.8	10.93											159	109	2.0	31.7	290	1.0	12.60											150	115	1.9	30.1	306	0.9	13.30											131	132	1.9	26.1	353	0.9	15.30											110	157	1.6	22.0	420	0.8	18.21											104	166	1.5	20.8	443	0.7	19.24											94.6	183	1.4	18.9	487	0.7	21.15											252	69	3.4	50.4	183	1.6	7.93	CMGV 042/15												220	78	3.2	44.1	209	1.5	9.08												183		94	2.6	36.6	252	1.3	10.93												159	109		2.9	31.7	290	1.4	12.60												150	115	2.7		30.1	306	1.3	13.30											131	132	2.8	26.1	353	1.4	15.30												110	157	2.4	22.0	420	1.2	18.21											104	166	2.2	20.8	443	1.1	19.24											65.4	264	1.7	13.1	704	0.8	30.57											45.3	382	1.2	9.1	1018	0.6	44.18	1.5									1.5									90L4 n ₁ =1400 [min ⁻¹]	267	43	3.9	53.4	86	2.0	3.74	CMGV 032/15												222	52	3.2	44.4	104	1.7	4.50			182	63	2.7	36.5	126	1.4	5.48		159	73		2.8	31.7	145	1.4	6.31		126	91	2.2		25.2	183	1.1	7.93		110	105	1.9	22.0		209	1.0	9.08		91.5	126	1.6	18.3	252		0.8	10.93		79.3	145	1.9	15.9	290	1.0		12.60		75.2	153	1.8	15.0	306	0.9	13.30		65.4	176	1.8	13.1	353	0.9	15.30		54.9	210	1.5	11.0	420	0.8	18.21		52.0	222	1.4		10.4	443	0.7	19.24		47.3	244	1.3	9.5	487	0.7	21.15																																																																																																																																
	31.1	278	3.6	6.2	555	1.9	32.13		CMGV 052/15	21.6	534	1.9	4.3	1067	1.0	46.31																																																																																																																																																																																																																																																																																																																																																																																																																																																																																																																																																																																																																																																																																																																																																																																																																																																										
	21.6	400	2.5	4.3	800	1.3	46.31			22.1	382	1.5	4.4	765	0.8	45.21	CMGV 043/15	17.8		632	1.6	3.6	1264	0.8	56.05	CMGV 053/15		16.3		519	1.1	3.3	1038	0.6	61.32		17.8	474		2.1	3.6	948	1.1	56.05			15.5	545	1.8		3.1	1091	0.9	64.48				13.3	634		1.6	2.7	1268	0.8			74.96		12.3		686	1.5	2.5	1372			0.8	81.07			11.6	730	1.4	2.3			1459	0.7	86.24			9.2	917	1.1			1.8	1835	0.6	108.43		11.6	730			1.4	2.3	1459	0.7	86.24		9.2			917	1.1	1.8	1835	0.6	108.43	2.2									2.2																		90L2 n ₁ =2800 [min ⁻¹]	534	32	4.1	107	86	2.0	3.74	CMGV 032/15											444	39	3.4	88.8	104	1.7	4.50												365	47	2.8	72.9	126	1.4	5.48													317	55	2.9	63.4	145	1.4	6.31												252	69		2.3	50.4	183	1.1	7.93												220	78	2.0		44.1	209	1.0	9.08												183	94	1.7	36.6	252	0.8	10.93											159	109	2.0	31.7	290	1.0	12.60											150	115	1.9	30.1	306	0.9	13.30											131	132	1.9	26.1	353	0.9	15.30											110	157	1.6	22.0	420	0.8	18.21											104	166	1.5	20.8	443	0.7	19.24											94.6	183	1.4	18.9	487	0.7	21.15											252	69	3.4	50.4	183	1.6	7.93	CMGV 042/15											220	78	3.2	44.1	209	1.5	9.08												183	94	2.6	36.6	252	1.3	10.93													159	109	2.9	31.7	290	1.4	12.60												150	115		2.7	30.1	306	1.3	13.30												131	132	2.8		26.1	353	1.4	15.30												110	157	2.4	22.0	420	1.2	18.21											104	166	2.2	20.8	443	1.1	19.24											65.4	264	1.7	13.1	704	0.8	30.57											45.3	382	1.2	9.1	1018	0.6	44.18	1.5									1.5									90L4 n ₁ =1400 [min ⁻¹]	267	43	3.9	53.4	86	2.0	3.74	CMGV 032/15											222	52	3.2	44.4	104	1.7	4.50		182	63	2.7	36.5	126	1.4	5.48			159	73	2.8	31.7	145	1.4	6.31		126		91	2.2	25.2	183	1.1	7.93		110	105		1.9	22.0	209	1.0	9.08		91.5	126	1.6	18.3		252	0.8	10.93		79.3	145	1.9	15.9	290		1.0	12.60		75.2	153	1.8	15.0	306	0.9		13.30		65.4	176	1.8	13.1	353	0.9	15.30			54.9	210	1.5	11.0	420	0.8	18.21			52.0	222	1.4	10.4	443	0.7	19.24		47.3	244	1.3	9.5	487	0.7	21.15																																																																																																																																																											
	22.1	382	1.5	4.4	765	0.8	45.21	CMGV 043/15		17.8	632	1.6	3.6	1264	0.8	56.05		CMGV 053/15																																																																																																																																																																																																																																																																																																																																																																																																																																																																																																																																																																																																																																																																																																																																																																																																																																																								
	16.3	519	1.1	3.3	1038	0.6	61.32				17.8	474	2.1	3.6	948	1.1				56.05		15.5	545	1.8	3.1		1091	0.9		64.48		13.3	634	1.6	2.7	1268	0.8	74.96			12.3	686	1.5	2.5	1372		0.8	81.07			11.6	730	1.4	2.3			1459	0.7	86.24			9.2	917	1.1			1.8	1835	0.6		108.43		11.6	730			1.4	2.3	1459	0.7	86.24		9.2	917			1.1	1.8	1835	0.6	108.43	2.2									2.2																		90L2 n ₁ =2800 [min ⁻¹]	534	32	4.1	107	86	2.0	3.74	CMGV 032/15											444	39	3.4	88.8	104	1.7	4.50											365		47	2.8	72.9	126	1.4	5.48											317	55	2.9	63.4	145	1.4	6.31												252	69		2.3	50.4	183	1.1	7.93												220	78	2.0	44.1		209	1.0	9.08												183	94	1.7	36.6	252		0.8	10.93											159	109	2.0	31.7	290	1.0	12.60											150	115	1.9	30.1	306	0.9	13.30											131	132	1.9	26.1	353	0.9	15.30											110	157	1.6	22.0	420	0.8	18.21											104	166	1.5	20.8	443	0.7	19.24											94.6	183	1.4	18.9	487	0.7	21.15											252	69	3.4	50.4	183	1.6	7.93	CMGV 042/15											220	78	3.2	44.1	209	1.5	9.08											183	94		2.6	36.6	252	1.3	10.93											159	109	2.9	31.7	290	1.4	12.60												150	115	2.7		30.1	306	1.3	13.30												131	132	2.8	26.1	353		1.4	15.30												110	157	2.4	22.0	420	1.2		18.21											104	166	2.2	20.8	443	1.1	19.24											65.4	264	1.7	13.1	704	0.8	30.57											45.3	382	1.2	9.1	1018	0.6	44.18	1.5									1.5									90L4 n ₁ =1400 [min ⁻¹]	267	43	3.9	53.4	86	2.0	3.74	CMGV 032/15											222	52	3.2	44.4	104	1.7	4.50		182	63	2.7	36.5	126	1.4	5.48		159	73	2.8	31.7		145	1.4	6.31		126	91	2.2	25.2	183	1.1	7.93		110	105	1.9	22.0	209	1.0	9.08		91.5	126	1.6	18.3	252	0.8		10.93		79.3	145	1.9	15.9	290	1.0	12.60			75.2	153	1.8	15.0	306	0.9	13.30			65.4	176	1.8	13.1	353	0.9	15.30		54.9	210		1.5	11.0	420	0.8	18.21		52.0	222	1.4		10.4	443	0.7	19.24		47.3	244	1.3	9.5		487	0.7	21.15																																																																																																																																																																																											
	17.8	474	2.1	3.6	948	1.1	56.05				15.5	545	1.8	3.1	1091	0.9				64.48		13.3	634	1.6	2.7		1268	0.8		74.96		12.3	686	1.5	2.5	1372	0.8	81.07			11.6	730	1.4	2.3	1459		0.7	86.24			9.2	917	1.1	1.8			1835	0.6	108.43			11.6	730	1.4			2.3	1459	0.7	86.24		9.2	917	1.1			1.8	1835	0.6	108.43	2.2									2.2																		90L2 n ₁ =2800 [min ⁻¹]	534	32	4.1	107	86	2.0	3.74	CMGV 032/15												444	39	3.4	88.8	104	1.7	4.50											365	47	2.8	72.9	126	1.4	5.48												317	55	2.9	63.4	145	1.4	6.31											252	69	2.3		50.4	183	1.1	7.93												220	78	2.0	44.1		209	1.0	9.08												183	94	1.7	36.6	252	0.8		10.93											159	109	2.0	31.7	290	1.0	12.60											150	115	1.9	30.1	306	0.9	13.30											131	132	1.9	26.1	353	0.9	15.30											110	157	1.6	22.0	420	0.8	18.21											104	166	1.5	20.8	443	0.7	19.24											94.6	183	1.4	18.9	487	0.7	21.15											252	69	3.4	50.4	183	1.6	7.93	CMGV 042/15												220	78	3.2	44.1	209	1.5	9.08											183	94	2.6	36.6	252	1.3	10.93												159	109	2.9	31.7	290	1.4	12.60											150	115	2.7	30.1		306	1.3	13.30												131	132	2.8	26.1	353		1.4	15.30												110	157	2.4	22.0	420	1.2	18.21												104	166	2.2	20.8	443	1.1	19.24											65.4	264	1.7	13.1	704	0.8	30.57											45.3	382	1.2	9.1	1018	0.6	44.18	1.5									1.5									90L4 n ₁ =1400 [min ⁻¹]	267	43	3.9	53.4	86	2.0	3.74	CMGV 032/15												222	52	3.2	44.4	104	1.7	4.50		182	63	2.7	36.5	126	1.4	5.48		159	73	2.8	31.7	145	1.4	6.31		126	91	2.2	25.2	183	1.1		7.93		110	105	1.9	22.0	209	1.0	9.08		91.5	126	1.6	18.3	252	0.8	10.93		79.3	145	1.9	15.9	290	1.0	12.60			75.2	153	1.8	15.0	306	0.9	13.30		65.4		176	1.8	13.1	353	0.9	15.30		54.9	210		1.5	11.0	420	0.8	18.21		52.0	222	1.4	10.4		443	0.7	19.24		47.3	244	1.3	9.5	487		0.7	21.15																																																																																																																																																																																																						
	15.5	545	1.8	3.1	1091	0.9	64.48				13.3	634	1.6	2.7	1268	0.8				74.96		12.3	686	1.5	2.5		1372	0.8		81.07		11.6	730	1.4	2.3	1459	0.7	86.24			9.2	917	1.1	1.8	1835		0.6	108.43			11.6	730	1.4	2.3			1459	0.7	86.24		9.2	917	1.1	1.8			1835	0.6	108.43	2.2									2.2																		90L2 n ₁ =2800 [min ⁻¹]	534	32	4.1	107	86	2.0	3.74	CMGV 032/15												444	39	3.4	88.8	104	1.7	4.50												365	47	2.8	72.9	126	1.4	5.48											317	55	2.9	63.4		145	1.4	6.31											252	69	2.3	50.4	183	1.1	7.93												220	78	2.0	44.1	209		1.0	9.08												183	94	1.7	36.6	252	0.8	10.93												159	109	2.0	31.7	290	1.0	12.60											150	115	1.9	30.1	306	0.9	13.30											131	132	1.9	26.1	353	0.9	15.30											110	157	1.6	22.0	420	0.8	18.21											104	166	1.5	20.8	443	0.7	19.24											94.6	183	1.4	18.9	487	0.7	21.15											252	69	3.4	50.4	183	1.6	7.93	CMGV 042/15												220	78	3.2	44.1	209	1.5	9.08												183	94	2.6	36.6	252	1.3	10.93											159	109	2.9	31.7	290		1.4	12.60											150	115	2.7	30.1	306	1.3	13.30												131	132	2.8	26.1	353	1.4		15.30												110	157	2.4	22.0	420	1.2	18.21												104	166	2.2	20.8	443	1.1	19.24											65.4	264	1.7	13.1	704	0.8	30.57											45.3	382	1.2	9.1	1018	0.6	44.18	1.5									1.5									90L4 n ₁ =1400 [min ⁻¹]	267	43	3.9	53.4	86	2.0	3.74	CMGV 032/15												222	52	3.2	44.4	104	1.7	4.50		182	63		2.7	36.5	126	1.4	5.48		159	73	2.8	31.7	145	1.4	6.31		126	91	2.2	25.2	183	1.1	7.93		110	105	1.9	22.0	209	1.0	9.08			91.5	126	1.6	18.3	252	0.8	10.93		79.3	145	1.9	15.9	290	1.0	12.60		75.2	153	1.8	15.0	306	0.9	13.30		65.4	176		1.8	13.1	353	0.9	15.30		54.9	210	1.5		11.0	420	0.8	18.21		52.0	222	1.4	10.4		443	0.7	19.24		47.3	244	1.3	9.5	487	0.7		21.15																																																																																																																																																																																																																	
	13.3	634	1.6	2.7	1268	0.8	74.96				12.3	686	1.5	2.5	1372	0.8				81.07		11.6	730	1.4	2.3		1459	0.7		86.24		9.2	917	1.1	1.8	1835	0.6	108.43			11.6	730	1.4	2.3	1459		0.7	86.24		9.2	917	1.1	1.8	1835			0.6	108.43	2.2									2.2																		90L2 n ₁ =2800 [min ⁻¹]	534	32	4.1	107	86	2.0	3.74	CMGV 032/15												444	39	3.4	88.8	104	1.7	4.50												365	47	2.8		72.9	126	1.4	5.48											317	55	2.9	63.4	145	1.4	6.31												252	69	2.3	50.4	183	1.1	7.93											220	78	2.0	44.1	209	1.0		9.08												183	94	1.7	36.6	252	0.8	10.93												159	109	2.0	31.7	290	1.0	12.60											150	115	1.9	30.1	306	0.9	13.30											131	132	1.9	26.1	353	0.9	15.30											110	157	1.6	22.0	420	0.8	18.21											104	166	1.5	20.8	443	0.7	19.24											94.6	183	1.4	18.9	487	0.7	21.15											252	69	3.4	50.4	183	1.6	7.93	CMGV 042/15												220	78	3.2	44.1	209	1.5	9.08												183	94	2.6		36.6	252	1.3	10.93											159	109	2.9	31.7	290	1.4	12.60												150	115	2.7	30.1	306	1.3	13.30											131	132	2.8	26.1	353	1.4	15.30													110	157	2.4	22.0	420	1.2	18.21												104	166	2.2	20.8	443	1.1	19.24											65.4	264	1.7	13.1	704	0.8	30.57											45.3	382	1.2	9.1	1018	0.6	44.18	1.5									1.5									90L4 n ₁ =1400 [min ⁻¹]	267	43	3.9	53.4	86	2.0	3.74	CMGV 032/15												222	52	3.2	44.4	104	1.7	4.50		182	63		2.7	36.5	126	1.4	5.48		159	73	2.8	31.7		145	1.4	6.31		126	91	2.2	25.2	183	1.1	7.93		110	105	1.9	22.0	209	1.0	9.08		91.5	126	1.6	18.3	252	0.8	10.93		79.3	145		1.9	15.9	290	1.0	12.60		75.2	153	1.8	15.0	306	0.9	13.30		65.4	176	1.8	13.1	353	0.9	15.30		54.9	210	1.5	11.0		420	0.8	18.21		52.0	222	1.4	10.4	443		0.7	19.24		47.3	244	1.3	9.5	487	0.7		21.15																																																																																																																																																																																																																												
	12.3	686	1.5	2.5	1372	0.8	81.07				11.6	730	1.4	2.3	1459	0.7				86.24		9.2	917	1.1	1.8		1835	0.6		108.43		11.6	730	1.4	2.3	1459	0.7	86.24		9.2	917	1.1	1.8	1835	0.6		108.43	2.2									2.2																		90L2 n ₁ =2800 [min ⁻¹]	534	32	4.1	107	86	2.0	3.74	CMGV 032/15												444	39	3.4	88.8	104	1.7	4.50												365	47	2.8		72.9	126	1.4	5.48												317	55	2.9	63.4	145	1.4	6.31											252	69	2.3	50.4	183	1.1	7.93												220	78	2.0	44.1	209	1.0	9.08												183	94	1.7	36.6	252	0.8	10.93												159	109	2.0	31.7	290	1.0	12.60											150	115	1.9	30.1	306	0.9	13.30											131	132	1.9	26.1	353	0.9	15.30											110	157	1.6	22.0	420	0.8	18.21											104	166	1.5	20.8	443	0.7	19.24											94.6	183	1.4	18.9	487	0.7	21.15											252	69	3.4	50.4	183	1.6	7.93	CMGV 042/15												220	78	3.2	44.1	209	1.5	9.08												183	94	2.6		36.6	252	1.3	10.93												159	109	2.9	31.7	290	1.4	12.60											150	115	2.7	30.1	306	1.3	13.30												131	132	2.8	26.1	353	1.4	15.30												110	157	2.4	22.0	420	1.2	18.21												104	166	2.2	20.8	443	1.1	19.24											65.4	264	1.7	13.1	704	0.8	30.57											45.3	382	1.2	9.1	1018	0.6	44.18	1.5									1.5									90L4 n ₁ =1400 [min ⁻¹]	267	43	3.9	53.4	86	2.0	3.74	CMGV 032/15												222	52	3.2	44.4	104	1.7	4.50		182	63		2.7	36.5	126	1.4	5.48		159	73	2.8	31.7		145	1.4	6.31		126	91	2.2	25.2	183	1.1		7.93		110	105	1.9	22.0	209	1.0	9.08		91.5	126	1.6	18.3	252	0.8	10.93		79.3	145	1.9	15.9	290	1.0	12.60		75.2	153	1.8	15.0		306	0.9	13.30		65.4	176	1.8	13.1	353	0.9	15.30		54.9	210	1.5	11.0	420	0.8	18.21		52.0	222	1.4	10.4	443	0.7		19.24		47.3	244	1.3	9.5	487	0.7	21.15																																																																																																																																																																																																																																								
	11.6	730	1.4	2.3	1459	0.7	86.24				9.2	917	1.1	1.8	1835	0.6				108.43		11.6	730	1.4	2.3		1459	0.7	86.24		9.2	917	1.1	1.8	1835	0.6	108.43	2.2									2.2																		90L2 n ₁ =2800 [min ⁻¹]	534	32	4.1	107	86	2.0	3.74	CMGV 032/15												444	39	3.4	88.8	104	1.7	4.50												365	47		2.8	72.9	126	1.4	5.48												317	55	2.9	63.4	145		1.4	6.31											252	69	2.3	50.4	183	1.1	7.93												220	78	2.0	44.1	209	1.0	9.08											183	94	1.7	36.6	252	0.8	10.93												159	109	2.0	31.7	290	1.0	12.60											150	115	1.9	30.1	306	0.9	13.30											131	132	1.9	26.1	353	0.9	15.30											110	157	1.6	22.0	420	0.8	18.21											104	166	1.5	20.8	443	0.7	19.24											94.6	183	1.4	18.9	487	0.7	21.15											252	69	3.4	50.4	183	1.6	7.93	CMGV 042/15												220	78	3.2	44.1	209	1.5	9.08												183	94		2.6	36.6	252	1.3	10.93												159	109	2.9	31.7	290		1.4	12.60											150	115	2.7	30.1	306	1.3	13.30												131	132	2.8	26.1	353	1.4	15.30											110	157	2.4	22.0	420	1.2	18.21												104	166	2.2	20.8	443	1.1	19.24											65.4	264	1.7	13.1	704	0.8	30.57											45.3	382	1.2	9.1	1018	0.6	44.18	1.5									1.5									90L4 n ₁ =1400 [min ⁻¹]	267	43	3.9	53.4	86	2.0	3.74	CMGV 032/15												222	52	3.2	44.4	104	1.7	4.50		182		63	2.7	36.5	126	1.4	5.48		159	73	2.8		31.7	145	1.4	6.31		126	91	2.2	25.2	183		1.1	7.93		110	105	1.9	22.0	209	1.0	9.08			91.5	126	1.6	18.3	252	0.8	10.93		79.3	145	1.9	15.9	290	1.0	12.60		75.2	153	1.8	15.0	306	0.9	13.30		65.4	176	1.8	13.1	353		0.9	15.30		54.9	210	1.5	11.0	420	0.8	18.21		52.0	222	1.4	10.4	443	0.7	19.24		47.3	244	1.3	9.5	487	0.7	21.15																																																																																																																																																																																																																																																		
	9.2	917	1.1	1.8	1835	0.6	108.43				11.6	730	1.4	2.3	1459	0.7			86.24		9.2	917	1.1	1.8	1835		0.6	108.43	2.2									2.2																		90L2 n ₁ =2800 [min ⁻¹]	534	32	4.1	107	86	2.0	3.74	CMGV 032/15												444	39	3.4	88.8	104	1.7	4.50													365	47	2.8	72.9	126	1.4	5.48												317	55	2.9		63.4	145	1.4	6.31												252	69	2.3	50.4	183	1.1	7.93											220	78	2.0	44.1	209	1.0	9.08												183	94	1.7	36.6	252	0.8	10.93											159	109	2.0	31.7	290	1.0	12.60											150	115	1.9	30.1	306	0.9	13.30											131	132	1.9	26.1	353	0.9	15.30											110	157	1.6	22.0	420	0.8	18.21											104	166	1.5	20.8	443	0.7	19.24											94.6	183	1.4	18.9	487	0.7	21.15											252	69	3.4	50.4	183	1.6	7.93	CMGV 042/15												220	78	3.2	44.1	209	1.5	9.08													183	94	2.6	36.6	252	1.3	10.93												159	109	2.9		31.7	290	1.4	12.60												150	115	2.7	30.1	306	1.3	13.30											131	132	2.8	26.1	353	1.4	15.30												110	157	2.4	22.0	420	1.2	18.21											104	166	2.2	20.8	443	1.1	19.24											65.4	264	1.7	13.1	704	0.8	30.57											45.3	382	1.2	9.1	1018	0.6	44.18	1.5									1.5									90L4 n ₁ =1400 [min ⁻¹]	267	43	3.9	53.4	86	2.0	3.74	CMGV 032/15												222	52	3.2	44.4	104	1.7	4.50			182	63	2.7	36.5	126	1.4	5.48		159		73	2.8	31.7	145	1.4	6.31		126	91	2.2		25.2	183	1.1	7.93		110	105	1.9	22.0	209		1.0	9.08		91.5	126	1.6	18.3	252	0.8	10.93			79.3	145	1.9	15.9	290	1.0	12.60		75.2	153	1.8	15.0	306	0.9	13.30		65.4	176	1.8	13.1	353	0.9	15.30		54.9	210	1.5	11.0	420		0.8	18.21		52.0	222	1.4	10.4	443	0.7	19.24		47.3	244	1.3	9.5	487	0.7	21.15																																																																																																																																																																																																																																																										
	11.6	730	1.4	2.3	1459	0.7	86.24			9.2	917	1.1	1.8	1835	0.6	108.43			2.2									2.2																		90L2 n ₁ =2800 [min ⁻¹]	534	32	4.1	107	86	2.0	3.74	CMGV 032/15												444	39	3.4	88.8	104	1.7	4.50													365	47	2.8	72.9	126	1.4	5.48												317	55		2.9	63.4	145	1.4	6.31												252	69	2.3	50.4	183		1.1	7.93											220	78	2.0	44.1	209	1.0	9.08												183	94	1.7	36.6	252	0.8	10.93											159	109	2.0	31.7	290	1.0	12.60											150	115	1.9	30.1	306	0.9	13.30											131	132	1.9	26.1	353	0.9	15.30											110	157	1.6	22.0	420	0.8	18.21											104	166	1.5	20.8	443	0.7	19.24											94.6	183	1.4	18.9	487	0.7	21.15											252	69	3.4	50.4	183	1.6	7.93	CMGV 042/15												220	78	3.2	44.1	209	1.5		9.08												183	94	2.6	36.6	252	1.3	10.93												159		109	2.9	31.7	290	1.4	12.60												150	115	2.7	30.1		306	1.3	13.30											131	132	2.8	26.1	353	1.4	15.30												110	157	2.4	22.0	420	1.2	18.21											104	166	2.2	20.8	443	1.1	19.24											65.4	264	1.7	13.1	704	0.8	30.57											45.3	382	1.2	9.1	1018	0.6	44.18	1.5									1.5									90L4 n ₁ =1400 [min ⁻¹]	267	43	3.9	53.4	86	2.0	3.74	CMGV 032/15												222	52	3.2	44.4	104		1.7	4.50		182	63	2.7	36.5	126	1.4		5.48		159	73	2.8	31.7	145	1.4	6.31			126	91	2.2	25.2	183	1.1	7.93		110	105		1.9	22.0	209	1.0	9.08		91.5	126	1.6	18.3		252	0.8	10.93		79.3	145	1.9	15.9	290	1.0		12.60		75.2	153	1.8	15.0	306	0.9	13.30		65.4	176	1.8	13.1	353	0.9	15.30		54.9	210	1.5	11.0	420	0.8	18.21		52.0	222	1.4	10.4		443	0.7	19.24		47.3	244	1.3	9.5	487	0.7	21.15																																																																																																																																																																																																																																																																	
	9.2	917	1.1	1.8	1835	0.6	108.43																																																																																																																																																																																																																																																																																																																																																																																																																																																																																																																																																																																																																																																																																																																																																																																																																																																																			
2.2									2.2																																																																																																																																																																																																																																																																																																																																																																																																																																																																																																																																																																																																																																																																																																																																																																																																																																																																	
									90L2 n ₁ =2800 [min ⁻¹]	534	32	4.1	107	86	2.0	3.74	CMGV 032/15																																																																																																																																																																																																																																																																																																																																																																																																																																																																																																																																																																																																																																																																																																																																																																																																																																																									
										444	39	3.4	88.8	104	1.7	4.50												365	47	2.8	72.9	126	1.4	5.48											317	55	2.9	63.4	145	1.4	6.31												252		69	2.3	50.4	183	1.1	7.93												220		78	2.0	44.1	209	1.0	9.08												183	94	1.7	36.6		252	0.8	10.93											159	109	2.0	31.7	290	1.0	12.60											150	115	1.9	30.1	306	0.9	13.30											131	132	1.9	26.1	353	0.9	15.30											110	157	1.6	22.0	420	0.8	18.21											104	166	1.5	20.8	443	0.7	19.24											94.6	183	1.4	18.9	487	0.7	21.15											252	69	3.4	50.4	183	1.6	7.93	CMGV 042/15											220	78	3.2	44.1	209	1.5	9.08											183	94	2.6	36.6	252	1.3	10.93											159	109	2.9	31.7	290	1.4	12.60												150	115		2.7	30.1	306	1.3	13.30												131	132		2.8	26.1	353	1.4	15.30												110	157	2.4	22.0	420		1.2	18.21											104	166	2.2	20.8	443	1.1	19.24											65.4	264	1.7	13.1	704	0.8	30.57											45.3	382	1.2	9.1	1018	0.6	44.18	1.5									1.5									90L4 n ₁ =1400 [min ⁻¹]	267	43	3.9	53.4	86	2.0	3.74	CMGV 032/15											222	52	3.2	44.4	104	1.7	4.50		182	63	2.7	36.5	126	1.4	5.48		159	73	2.8	31.7	145	1.4	6.31		126	91	2.2	25.2	183	1.1	7.93		110	105	1.9	22.0	209	1.0	9.08		91.5	126	1.6	18.3	252	0.8	10.93			79.3	145	1.9	15.9	290	1.0		12.60		75.2	153	1.8	15.0	306	0.9		13.30		65.4	176	1.8	13.1	353	0.9	15.30			54.9	210	1.5	11.0	420	0.8	18.21		52.0		222	1.4	10.4	443	0.7	19.24		47.3	244	1.3		9.5	487	0.7	21.15																																																																																																																																																																																																																																																																																																																													
										365	47	2.8	72.9	126	1.4	5.48												317	55	2.9	63.4	145	1.4	6.31											252	69	2.3	50.4	183	1.1	7.93												220		78	2.0	44.1	209	1.0	9.08												183		94	1.7	36.6	252	0.8	10.93												159	109	2.0	31.7	290	1.0	12.60											150	115	1.9	30.1	306	0.9	13.30											131	132	1.9	26.1	353	0.9	15.30											110	157	1.6	22.0	420	0.8	18.21											104	166	1.5	20.8	443	0.7	19.24											94.6	183	1.4	18.9	487	0.7	21.15											252	69	3.4	50.4	183	1.6	7.93	CMGV 042/15											220	78	3.2	44.1	209	1.5	9.08												183	94	2.6	36.6	252	1.3	10.93											159	109	2.9	31.7	290	1.4	12.60											150	115	2.7	30.1	306	1.3	13.30												131	132		2.8	26.1	353	1.4	15.30												110	157		2.4	22.0	420	1.2	18.21												104	166	2.2	20.8	443	1.1	19.24											65.4	264	1.7	13.1	704	0.8	30.57											45.3	382	1.2	9.1	1018	0.6	44.18	1.5									1.5									90L4 n ₁ =1400 [min ⁻¹]	267	43	3.9	53.4	86	2.0	3.74	CMGV 032/15											222	52	3.2	44.4	104	1.7	4.50			182	63	2.7	36.5	126	1.4	5.48		159	73	2.8	31.7	145	1.4	6.31		126	91	2.2	25.2	183	1.1	7.93		110	105	1.9	22.0	209	1.0	9.08		91.5	126	1.6	18.3	252	0.8	10.93		79.3	145	1.9	15.9	290	1.0	12.60		75.2	153	1.8	15.0	306	0.9	13.30			65.4	176	1.8	13.1	353	0.9	15.30			54.9	210	1.5	11.0	420	0.8	18.21			52.0	222	1.4	10.4	443	0.7	19.24			47.3	244	1.3	9.5	487	0.7	21.15																																																																																																																																																																																																																																																																																																																																																
										317	55	2.9	63.4	145	1.4	6.31												252	69	2.3	50.4	183	1.1	7.93											220	78	2.0	44.1	209	1.0	9.08												183		94	1.7	36.6	252	0.8	10.93												159		109	2.0	31.7	290	1.0	12.60											150	115	1.9	30.1	306	0.9	13.30											131	132	1.9	26.1	353	0.9	15.30											110	157	1.6	22.0	420	0.8	18.21											104	166	1.5	20.8	443	0.7	19.24											94.6	183	1.4	18.9	487	0.7	21.15											252	69	3.4	50.4	183	1.6	7.93	CMGV 042/15											220	78	3.2	44.1	209	1.5	9.08												183	94	2.6	36.6	252	1.3	10.93												159	109	2.9	31.7	290	1.4	12.60											150	115	2.7	30.1	306	1.3	13.30											131	132	2.8	26.1	353	1.4	15.30												110	157		2.4	22.0	420	1.2	18.21												104	166		2.2	20.8	443	1.1	19.24											65.4	264	1.7	13.1	704	0.8	30.57											45.3	382	1.2	9.1	1018	0.6	44.18	1.5									1.5									90L4 n ₁ =1400 [min ⁻¹]	267	43	3.9	53.4	86	2.0	3.74	CMGV 032/15											222	52	3.2	44.4	104	1.7	4.50			182	63	2.7	36.5	126	1.4	5.48		159	73	2.8	31.7	145	1.4	6.31			126	91	2.2	25.2	183	1.1	7.93		110	105	1.9	22.0	209	1.0	9.08		91.5	126	1.6	18.3	252	0.8	10.93		79.3	145	1.9	15.9	290	1.0	12.60		75.2	153	1.8	15.0	306	0.9	13.30		65.4	176	1.8	13.1	353	0.9	15.30		54.9	210	1.5	11.0	420	0.8	18.21		52.0		222	1.4	10.4	443	0.7	19.24			47.3	244	1.3	9.5	487	0.7	21.15																																																																																																																																																																																																																																																																																																																																																																			
										252	69	2.3	50.4	183	1.1	7.93												220	78	2.0	44.1	209	1.0	9.08											183	94	1.7	36.6	252	0.8	10.93												159		109	2.0	31.7	290	1.0	12.60												150	115	1.9	30.1	306	0.9	13.30											131	132	1.9	26.1	353	0.9	15.30											110	157	1.6	22.0	420	0.8	18.21											104	166	1.5	20.8	443	0.7	19.24											94.6	183	1.4	18.9	487	0.7	21.15											252	69	3.4	50.4	183	1.6	7.93	CMGV 042/15											220	78	3.2	44.1	209	1.5	9.08												183	94	2.6	36.6	252	1.3	10.93												159	109	2.9	31.7	290	1.4	12.60												150	115	2.7	30.1	306	1.3	13.30											131	132	2.8	26.1	353	1.4	15.30											110	157	2.4	22.0	420	1.2	18.21												104	166		2.2	20.8	443	1.1	19.24												65.4	264	1.7	13.1	704	0.8	30.57											45.3	382	1.2	9.1	1018	0.6	44.18	1.5									1.5									90L4 n ₁ =1400 [min ⁻¹]	267	43	3.9	53.4	86	2.0	3.74	CMGV 032/15											222	52	3.2	44.4	104	1.7	4.50			182	63	2.7	36.5	126	1.4	5.48		159	73	2.8	31.7	145	1.4	6.31			126	91	2.2	25.2	183	1.1	7.93		110	105	1.9	22.0	209	1.0	9.08		91.5		126	1.6	18.3	252	0.8	10.93		79.3	145	1.9	15.9	290	1.0	12.60		75.2	153	1.8	15.0	306	0.9	13.30		65.4	176	1.8	13.1	353	0.9	15.30		54.9	210	1.5	11.0	420	0.8	18.21		52.0	222	1.4	10.4	443	0.7	19.24		47.3	244	1.3	9.5	487	0.7	21.15																																																																																																																																																																																																																																																																																																																																																																																						
										220	78	2.0	44.1	209	1.0	9.08												183	94	1.7	36.6	252	0.8	10.93											159	109	2.0	31.7	290	1.0	12.60												150		115	1.9	30.1	306	0.9	13.30											131	132	1.9	26.1	353	0.9	15.30											110	157	1.6	22.0	420	0.8	18.21											104	166	1.5	20.8	443	0.7	19.24											94.6	183	1.4	18.9	487	0.7	21.15											252	69	3.4	50.4	183	1.6	7.93	CMGV 042/15											220	78	3.2	44.1	209	1.5	9.08												183	94	2.6	36.6	252	1.3	10.93												159	109	2.9	31.7	290	1.4	12.60												150	115	2.7	30.1	306	1.3	13.30												131	132	2.8	26.1	353	1.4	15.30											110	157	2.4	22.0	420	1.2	18.21											104	166	2.2	20.8	443	1.1	19.24												65.4	264		1.7	13.1	704	0.8	30.57											45.3	382	1.2	9.1	1018	0.6	44.18	1.5									1.5									90L4 n ₁ =1400 [min ⁻¹]	267	43	3.9	53.4	86	2.0	3.74	CMGV 032/15											222	52	3.2	44.4	104	1.7	4.50			182	63	2.7	36.5	126	1.4	5.48		159	73	2.8	31.7	145	1.4	6.31			126	91	2.2	25.2	183	1.1	7.93		110	105	1.9	22.0	209	1.0	9.08		91.5		126	1.6	18.3	252	0.8	10.93		79.3	145	1.9	15.9	290	1.0	12.60		75.2	153		1.8	15.0	306	0.9	13.30		65.4	176	1.8	13.1	353	0.9	15.30		54.9	210	1.5	11.0	420	0.8	18.21		52.0	222	1.4	10.4	443	0.7	19.24		47.3	244	1.3	9.5	487	0.7	21.15																																																																																																																																																																																																																																																																																																																																																																																																							
										183	94	1.7	36.6	252	0.8	10.93												159	109	2.0	31.7	290	1.0	12.60											150	115	1.9	30.1	306	0.9	13.30												131	132	1.9	26.1	353	0.9	15.30											110	157	1.6	22.0	420	0.8	18.21											104	166	1.5	20.8	443	0.7	19.24											94.6	183	1.4	18.9	487	0.7	21.15											252	69	3.4	50.4	183	1.6	7.93	CMGV 042/15											220	78	3.2	44.1	209	1.5	9.08												183	94	2.6	36.6	252	1.3	10.93												159	109	2.9	31.7	290	1.4	12.60												150	115	2.7	30.1	306	1.3	13.30												131	132	2.8	26.1	353	1.4	15.30												110	157	2.4	22.0	420	1.2	18.21											104	166	2.2	20.8	443	1.1	19.24											65.4	264	1.7	13.1	704	0.8	30.57												45.3	382	1.2	9.1	1018	0.6	44.18	1.5									1.5									90L4 n ₁ =1400 [min ⁻¹]	267	43	3.9	53.4	86	2.0	3.74	CMGV 032/15											222	52	3.2	44.4	104	1.7	4.50			182	63	2.7	36.5	126	1.4	5.48		159	73	2.8	31.7	145	1.4	6.31			126	91	2.2	25.2	183	1.1	7.93		110	105	1.9	22.0	209	1.0	9.08		91.5		126	1.6	18.3	252	0.8	10.93		79.3	145	1.9	15.9	290	1.0	12.60		75.2	153		1.8	15.0	306	0.9	13.30		65.4	176	1.8	13.1	353	0.9	15.30		54.9	210	1.5		11.0	420	0.8	18.21		52.0	222	1.4	10.4	443	0.7	19.24		47.3	244	1.3	9.5	487	0.7	21.15																																																																																																																																																																																																																																																																																																																																																																																																																								
										159	109	2.0	31.7	290	1.0	12.60												150	115	1.9	30.1	306	0.9	13.30											131	132	1.9	26.1	353	0.9	15.30											110	157	1.6	22.0	420	0.8	18.21											104	166	1.5	20.8	443	0.7	19.24											94.6	183	1.4	18.9	487	0.7	21.15											252	69	3.4	50.4	183	1.6	7.93	CMGV 042/15											220	78	3.2	44.1	209	1.5	9.08												183	94	2.6	36.6	252	1.3	10.93												159	109	2.9	31.7	290	1.4	12.60												150	115	2.7	30.1	306	1.3	13.30												131	132	2.8	26.1	353	1.4	15.30												110	157	2.4	22.0	420	1.2	18.21												104	166	2.2	20.8	443	1.1	19.24											65.4	264	1.7	13.1	704	0.8	30.57											45.3	382	1.2	9.1	1018	0.6	44.18	1.5									1.5									90L4 n ₁ =1400 [min ⁻¹]	267	43	3.9	53.4	86	2.0	3.74	CMGV 032/15											222	52	3.2	44.4	104	1.7	4.50			182	63	2.7	36.5	126	1.4	5.48		159	73	2.8	31.7	145	1.4	6.31			126	91	2.2	25.2	183	1.1	7.93		110	105	1.9	22.0	209	1.0	9.08		91.5		126	1.6	18.3	252	0.8	10.93		79.3	145	1.9	15.9	290	1.0	12.60		75.2	153		1.8	15.0	306	0.9	13.30		65.4	176	1.8	13.1	353	0.9	15.30		54.9	210	1.5		11.0	420	0.8	18.21		52.0	222	1.4	10.4	443	0.7	19.24		47.3	244	1.3	9.5		487	0.7	21.15																																																																																																																																																																																																																																																																																																																																																																																																																																									
										150	115	1.9	30.1	306	0.9	13.30												131	132	1.9	26.1	353	0.9	15.30											110	157	1.6	22.0	420	0.8	18.21											104	166	1.5	20.8	443	0.7	19.24											94.6	183	1.4	18.9	487	0.7	21.15											252	69	3.4	50.4	183	1.6	7.93	CMGV 042/15											220	78	3.2	44.1	209	1.5		9.08											183	94	2.6	36.6	252	1.3		10.93											159	109	2.9	31.7	290	1.4		12.60											150	115	2.7	30.1	306	1.3		13.30											131	132	2.8	26.1	353	1.4		15.30											110	157	2.4	22.0	420	1.2		18.21											104	166	2.2	20.8	443	1.1		19.24											65.4	264	1.7	13.1	704	0.8	30.57											45.3	382	1.2	9.1	1018	0.6	44.18	1.5									1.5									90L4 n ₁ =1400 [min ⁻¹]	267	43	3.9	53.4	86	2.0	3.74	CMGV 032/15											222	52	3.2	44.4	104		1.7	4.50		182	63	2.7	36.5	126	1.4	5.48		159	73	2.8	31.7	145	1.4		6.31		126	91	2.2	25.2	183	1.1	7.93		110	105	1.9	22.0	209	1.0	9.08			91.5	126	1.6	18.3	252	0.8	10.93		79.3	145	1.9	15.9	290	1.0	12.60			75.2	153	1.8	15.0	306	0.9	13.30		65.4	176	1.8	13.1	353	0.9	15.30		54.9		210	1.5	11.0	420	0.8	18.21		52.0	222	1.4	10.4	443	0.7	19.24		47.3	244		1.3	9.5	487	0.7	21.15																																																																																																																																																																																																																																																																																																																																																																																																																																																									
										131	132	1.9	26.1	353	0.9	15.30																																																																																																																																																																																																																																																																																																																																																																																																																																																																																																																																																																																																																																																																																																																																																																																																																																																										
										110	157	1.6	22.0	420	0.8	18.21											104	166	1.5	20.8	443	0.7	19.24											94.6	183	1.4	18.9	487	0.7	21.15											252	69	3.4	50.4	183	1.6	7.93	CMGV 042/15											220	78	3.2	44.1	209	1.5	9.08											183	94	2.6	36.6	252	1.3	10.93												159	109	2.9	31.7	290	1.4		12.60											150	115	2.7	30.1	306	1.3		13.30											131	132	2.8	26.1	353	1.4		15.30											110	157	2.4	22.0	420	1.2		18.21											104	166	2.2	20.8	443	1.1		19.24											65.4	264	1.7	13.1	704	0.8		30.57											45.3	382	1.2	9.1	1018	0.6		44.18	1.5									1.5									90L4 n ₁ =1400 [min ⁻¹]	267	43	3.9	53.4	86	2.0	3.74	CMGV 032/15											222	52	3.2	44.4	104	1.7	4.50		182	63	2.7	36.5	126	1.4	5.48		159	73	2.8	31.7	145	1.4	6.31			126	91	2.2	25.2	183	1.1	7.93		110	105	1.9	22.0	209	1.0		9.08		91.5	126	1.6	18.3	252	0.8	10.93		79.3	145	1.9	15.9	290	1.0	12.60			75.2	153	1.8	15.0	306	0.9	13.30		65.4	176	1.8	13.1	353	0.9	15.30			54.9	210	1.5	11.0	420	0.8	18.21		52.0	222	1.4	10.4	443	0.7	19.24		47.3		244	1.3	9.5	487	0.7	21.15																																																																																																																																																																																																																																																																																																																																																																																																																																																																																												
										104	166	1.5	20.8	443	0.7	19.24											94.6	183	1.4	18.9	487	0.7	21.15											252	69	3.4	50.4	183	1.6	7.93	CMGV 042/15											220	78	3.2	44.1	209	1.5		9.08											183	94	2.6	36.6	252	1.3	10.93											159	109	2.9	31.7	290	1.4		12.60											150	115	2.7	30.1	306		1.3	13.30											131	132	2.8	26.1	353		1.4	15.30											110	157	2.4	22.0	420		1.2	18.21											104	166	2.2	20.8	443		1.1	19.24											65.4	264	1.7	13.1	704		0.8	30.57											45.3	382	1.2	9.1	1018		0.6	44.18	1.5									1.5									90L4 n ₁ =1400 [min ⁻¹]	267	43	3.9	53.4	86	2.0	3.74	CMGV 032/15											222	52	3.2	44.4	104	1.7		4.50		182	63	2.7	36.5	126	1.4	5.48		159	73	2.8	31.7	145	1.4	6.31		126	91	2.2	25.2	183	1.1	7.93		110	105	1.9	22.0	209	1.0	9.08			91.5	126	1.6	18.3	252	0.8	10.93		79.3	145	1.9	15.9	290	1.0		12.60		75.2	153	1.8	15.0	306	0.9	13.30		65.4	176	1.8	13.1	353	0.9	15.30			54.9	210	1.5	11.0	420	0.8	18.21		52.0	222	1.4	10.4	443	0.7	19.24			47.3	244	1.3	9.5	487	0.7	21.15																																																																																																																																																																																																																																																																																																																																																																																																																																																																																																													
										94.6	183	1.4	18.9	487	0.7	21.15											252	69	3.4	50.4	183	1.6	7.93	CMGV 042/15											220	78	3.2	44.1	209	1.5		9.08											183	94	2.6	36.6	252		1.3	10.93											159	109	2.9	31.7	290	1.4	12.60											150	115	2.7	30.1	306		1.3	13.30											131	132	2.8	26.1		353	1.4	15.30											110	157	2.4	22.0		420	1.2	18.21											104	166	2.2	20.8		443	1.1	19.24											65.4	264	1.7	13.1		704	0.8	30.57											45.3	382	1.2	9.1		1018	0.6	44.18	1.5									1.5									90L4 n ₁ =1400 [min ⁻¹]	267	43	3.9	53.4	86	2.0	3.74	CMGV 032/15											222	52	3.2	44.4	104	1.7		4.50		182	63	2.7	36.5	126	1.4	5.48		159	73	2.8	31.7	145	1.4		6.31		126	91	2.2	25.2	183	1.1	7.93		110	105	1.9	22.0	209	1.0	9.08		91.5	126	1.6	18.3	252	0.8	10.93		79.3	145	1.9	15.9	290	1.0	12.60			75.2	153	1.8	15.0	306	0.9	13.30		65.4	176	1.8	13.1	353	0.9		15.30		54.9	210	1.5	11.0	420	0.8	18.21		52.0	222	1.4	10.4	443	0.7	19.24			47.3	244	1.3	9.5	487	0.7	21.15																																																																																																																																																																																																																																																																																																																																																																																																																																																																																																																														
										252	69	3.4	50.4	183	1.6	7.93	CMGV 042/15																																																																																																																																																																																																																																																																																																																																																																																																																																																																																																																																																																																																																																																																																																																																																																																																																																																									
										220	78	3.2	44.1	209	1.5	9.08												183	94	2.6	36.6	252	1.3		10.93											159	109	2.9	31.7	290		1.4	12.60											150	115	2.7	30.1		306	1.3	13.30											131	132	2.8	26.1	353	1.4	15.30											110	157	2.4	22.0		420	1.2	18.21											104	166	2.2		20.8	443	1.1	19.24											65.4	264	1.7		13.1	704	0.8	30.57											45.3	382	1.2		9.1	1018	0.6	44.18	1.5									1.5									90L4 n ₁ =1400 [min ⁻¹]	267	43	3.9	53.4	86	2.0	3.74	CMGV 032/15											222	52	3.2	44.4	104	1.7	4.50		182	63	2.7	36.5	126	1.4	5.48		159	73	2.8	31.7	145	1.4	6.31			126	91	2.2	25.2	183	1.1	7.93		110	105	1.9	22.0	209	1.0	9.08			91.5	126	1.6	18.3	252	0.8	10.93		79.3	145	1.9	15.9	290	1.0	12.60			75.2	153	1.8	15.0	306	0.9	13.30		65.4	176	1.8	13.1	353	0.9	15.30		54.9	210	1.5	11.0	420	0.8	18.21		52.0	222	1.4	10.4	443	0.7	19.24		47.3		244	1.3	9.5	487	0.7	21.15																																																																																																																																																																																																																																																																																																																																																																																																																																																																																																																																																																		
										183	94	2.6	36.6	252	1.3	10.93												159	109	2.9	31.7	290	1.4		12.60											150	115	2.7	30.1	306		1.3	13.30											131	132	2.8	26.1		353	1.4	15.30											110	157	2.4	22.0	420	1.2	18.21											104	166	2.2	20.8		443	1.1	19.24											65.4	264	1.7		13.1	704	0.8	30.57											45.3	382	1.2		9.1	1018	0.6	44.18	1.5									1.5									90L4 n ₁ =1400 [min ⁻¹]	267	43	3.9	53.4	86	2.0	3.74	CMGV 032/15											222	52	3.2	44.4	104	1.7	4.50			182	63	2.7	36.5	126	1.4	5.48		159	73	2.8	31.7	145	1.4	6.31		126	91	2.2	25.2	183	1.1	7.93		110	105	1.9	22.0	209	1.0	9.08		91.5		126	1.6	18.3	252	0.8	10.93		79.3	145	1.9	15.9	290	1.0	12.60		75.2		153	1.8	15.0	306	0.9	13.30		65.4	176	1.8	13.1	353	0.9	15.30		54.9		210	1.5	11.0	420	0.8	18.21		52.0	222	1.4	10.4	443	0.7	19.24		47.3	244	1.3	9.5	487	0.7	21.15																																																																																																																																																																																																																																																																																																																																																																																																																																																																																																																																																																																				
										159	109	2.9	31.7	290	1.4	12.60												150	115	2.7	30.1	306	1.3		13.30											131	132	2.8	26.1	353		1.4	15.30											110	157	2.4	22.0		420	1.2	18.21											104	166	2.2	20.8	443	1.1	19.24											65.4	264	1.7	13.1		704	0.8	30.57											45.3	382	1.2		9.1	1018	0.6	44.18	1.5									1.5									90L4 n ₁ =1400 [min ⁻¹]	267	43	3.9	53.4	86	2.0	3.74	CMGV 032/15											222	52	3.2	44.4	104	1.7	4.50			182	63	2.7	36.5	126	1.4	5.48		159	73	2.8	31.7	145	1.4	6.31			126	91	2.2	25.2	183	1.1	7.93		110	105	1.9	22.0	209	1.0	9.08		91.5	126	1.6	18.3	252	0.8	10.93		79.3	145	1.9	15.9	290	1.0	12.60		75.2	153		1.8	15.0	306	0.9	13.30		65.4	176	1.8	13.1	353	0.9	15.30		54.9	210		1.5	11.0	420	0.8	18.21		52.0	222	1.4	10.4	443	0.7	19.24		47.3	244		1.3	9.5	487	0.7	21.15																																																																																																																																																																																																																																																																																																																																																																																																																																																																																																																																																																																																					
										150	115	2.7	30.1	306	1.3	13.30												131	132	2.8	26.1	353	1.4		15.30											110	157	2.4	22.0	420		1.2	18.21											104	166	2.2	20.8		443	1.1	19.24											65.4	264	1.7	13.1	704	0.8	30.57											45.3	382	1.2	9.1		1018	0.6	44.18	1.5									1.5									90L4 n ₁ =1400 [min ⁻¹]	267	43	3.9	53.4	86	2.0	3.74	CMGV 032/15											222	52	3.2	44.4	104	1.7	4.50			182	63	2.7	36.5	126	1.4	5.48		159	73	2.8	31.7	145	1.4	6.31			126	91	2.2	25.2	183	1.1	7.93		110	105	1.9	22.0	209	1.0	9.08		91.5		126	1.6	18.3	252	0.8	10.93		79.3	145	1.9	15.9	290	1.0	12.60		75.2	153	1.8	15.0	306	0.9	13.30		65.4	176	1.8	13.1	353	0.9	15.30		54.9	210	1.5		11.0	420	0.8	18.21		52.0	222	1.4	10.4	443	0.7	19.24		47.3	244	1.3		9.5	487	0.7	21.15																																																																																																																																																																																																																																																																																																																																																																																																																																																																																																																																																																																																																							
										131	132	2.8	26.1	353	1.4	15.30												110	157	2.4	22.0	420	1.2		18.21											104	166	2.2	20.8	443		1.1	19.24											65.4	264	1.7	13.1		704	0.8	30.57											45.3	382	1.2	9.1	1018	0.6	44.18	1.5									1.5									90L4 n ₁ =1400 [min ⁻¹]	267	43	3.9	53.4	86	2.0	3.74	CMGV 032/15											222	52	3.2	44.4	104	1.7	4.50			182	63	2.7	36.5	126	1.4	5.48		159	73	2.8	31.7	145	1.4	6.31			126	91	2.2	25.2	183	1.1	7.93		110	105	1.9	22.0	209	1.0	9.08		91.5		126	1.6	18.3	252	0.8	10.93		79.3	145	1.9	15.9	290	1.0	12.60		75.2	153		1.8	15.0	306	0.9	13.30		65.4	176	1.8	13.1	353	0.9	15.30		54.9	210	1.5	11.0	420	0.8	18.21		52.0	222	1.4	10.4	443	0.7	19.24		47.3	244	1.3	9.5		487	0.7	21.15																																																																																																																																																																																																																																																																																																																																																																																																																																																																																																																																																																																																																																									
										110	157	2.4	22.0	420	1.2	18.21												104	166	2.2	20.8	443	1.1		19.24											65.4	264	1.7	13.1	704		0.8	30.57											45.3	382	1.2	9.1		1018	0.6	44.18	1.5									1.5									90L4 n ₁ =1400 [min ⁻¹]	267	43	3.9	53.4	86	2.0	3.74	CMGV 032/15											222	52	3.2	44.4	104	1.7		4.50		182	63	2.7	36.5	126	1.4	5.48		159	73	2.8	31.7	145	1.4	6.31			126	91	2.2	25.2	183	1.1	7.93		110	105	1.9	22.0	209	1.0	9.08			91.5	126	1.6	18.3	252	0.8	10.93		79.3	145	1.9	15.9	290	1.0	12.60		75.2		153	1.8	15.0	306	0.9	13.30		65.4	176	1.8	13.1	353	0.9	15.30		54.9	210		1.5	11.0	420	0.8	18.21		52.0	222	1.4	10.4	443	0.7	19.24		47.3	244	1.3	9.5	487	0.7	21.15																																																																																																																																																																																																																																																																																																																																																																																																																																																																																																																																																																																																																																																										
										104	166	2.2	20.8	443	1.1	19.24												65.4	264	1.7	13.1	704	0.8		30.57											45.3	382	1.2	9.1	1018		0.6	44.18	1.5									1.5									90L4 n ₁ =1400 [min ⁻¹]	267	43	3.9	53.4	86	2.0	3.74	CMGV 032/15											222	52	3.2	44.4	104	1.7	4.50			182	63	2.7	36.5	126	1.4	5.48		159	73	2.8	31.7	145	1.4	6.31			126	91	2.2	25.2	183	1.1	7.93		110	105	1.9	22.0	209	1.0	9.08			91.5	126	1.6	18.3	252	0.8	10.93		79.3	145	1.9	15.9	290	1.0	12.60		75.2		153	1.8	15.0	306	0.9	13.30		65.4	176	1.8	13.1	353	0.9	15.30		54.9	210		1.5	11.0	420	0.8	18.21		52.0	222	1.4	10.4	443	0.7	19.24		47.3	244	1.3		9.5	487	0.7	21.15																																																																																																																																																																																																																																																																																																																																																																																																																																																																																																																																																																																																																																																																											
										65.4	264	1.7	13.1	704	0.8	30.57												45.3	382	1.2	9.1	1018	0.6		44.18	1.5									1.5									90L4 n ₁ =1400 [min ⁻¹]	267	43	3.9	53.4	86	2.0	3.74	CMGV 032/15											222	52	3.2	44.4	104	1.7	4.50			182	63	2.7	36.5	126	1.4	5.48		159	73	2.8	31.7	145	1.4	6.31			126	91	2.2	25.2	183	1.1	7.93		110	105	1.9	22.0	209	1.0	9.08			91.5	126	1.6	18.3	252	0.8	10.93		79.3	145	1.9	15.9	290	1.0	12.60		75.2		153	1.8	15.0	306	0.9	13.30		65.4	176	1.8	13.1	353	0.9	15.30		54.9	210		1.5	11.0	420	0.8	18.21		52.0	222	1.4	10.4	443	0.7	19.24		47.3	244	1.3		9.5	487	0.7	21.15																																																																																																																																																																																																																																																																																																																																																																																																																																																																																																																																																																																																																																																																																													
										45.3	382	1.2	9.1	1018	0.6	44.18																																																																																																																																																																																																																																																																																																																																																																																																																																																																																																																																																																																																																																																																																																																																																																																																																																																										
1.5									1.5																																																																																																																																																																																																																																																																																																																																																																																																																																																																																																																																																																																																																																																																																																																																																																																																																																																																	
90L4 n ₁ =1400 [min ⁻¹]	267	43	3.9	53.4	86	2.0	3.74	CMGV 032/15																																																																																																																																																																																																																																																																																																																																																																																																																																																																																																																																																																																																																																																																																																																																																																																																																																																																		
	222	52	3.2	44.4	104	1.7	4.50			182	63	2.7	36.5	126	1.4	5.48		159	73	2.8	31.7	145	1.4	6.31		126	91	2.2	25.2	183	1.1	7.93		110	105	1.9	22.0	209	1.0	9.08		91.5	126	1.6	18.3	252	0.8	10.93		79.3	145	1.9	15.9	290	1.0	12.60		75.2	153	1.8	15.0		306	0.9	13.30		65.4	176	1.8	13.1	353	0.9	15.30		54.9	210	1.5	11.0	420		0.8	18.21		52.0	222	1.4	10.4	443	0.7	19.24		47.3	244	1.3	9.5	487	0.7		21.15																																																																																																																																																																																																																																																																																																																																																																																																																																																																																																																																																																																																																																																																																																																																																																							
	182	63	2.7	36.5	126	1.4	5.48			159	73	2.8	31.7	145	1.4	6.31		126	91	2.2	25.2	183	1.1	7.93		110	105	1.9	22.0	209	1.0	9.08		91.5	126	1.6	18.3	252	0.8	10.93		79.3	145	1.9	15.9	290	1.0	12.60		75.2	153	1.8	15.0	306	0.9	13.30		65.4	176	1.8	13.1		353	0.9	15.30		54.9	210	1.5	11.0	420	0.8	18.21		52.0	222	1.4	10.4	443		0.7	19.24		47.3	244	1.3	9.5	487	0.7	21.15																																																																																																																																																																																																																																																																																																																																																																																																																																																																																																																																																																																																																																																																																																																																																																																
	159	73	2.8	31.7	145	1.4	6.31			126	91	2.2	25.2	183	1.1	7.93		110	105	1.9	22.0	209	1.0	9.08		91.5	126	1.6	18.3	252	0.8	10.93		79.3	145	1.9	15.9	290	1.0	12.60		75.2	153	1.8	15.0	306	0.9	13.30		65.4	176	1.8	13.1	353	0.9	15.30		54.9	210	1.5	11.0		420	0.8	18.21		52.0	222	1.4	10.4	443	0.7	19.24		47.3	244	1.3	9.5	487		0.7	21.15																																																																																																																																																																																																																																																																																																																																																																																																																																																																																																																																																																																																																																																																																																																																																																																								
	126	91	2.2	25.2	183	1.1	7.93			110	105	1.9	22.0	209	1.0	9.08		91.5	126	1.6	18.3	252	0.8	10.93		79.3	145	1.9	15.9	290	1.0	12.60		75.2	153	1.8	15.0	306	0.9	13.30		65.4	176	1.8	13.1	353	0.9	15.30		54.9	210	1.5	11.0	420	0.8	18.21		52.0	222	1.4	10.4		443	0.7	19.24		47.3	244	1.3	9.5	487	0.7	21.15																																																																																																																																																																																																																																																																																																																																																																																																																																																																																																																																																																																																																																																																																																																																																																																																	
	110	105	1.9	22.0	209	1.0	9.08			91.5	126	1.6	18.3	252	0.8	10.93		79.3	145	1.9	15.9	290	1.0	12.60		75.2	153	1.8	15.0	306	0.9	13.30		65.4	176	1.8	13.1	353	0.9	15.30		54.9	210	1.5	11.0	420	0.8	18.21		52.0	222	1.4	10.4	443	0.7	19.24		47.3	244	1.3	9.5		487	0.7	21.15																																																																																																																																																																																																																																																																																																																																																																																																																																																																																																																																																																																																																																																																																																																																																																																																									
	91.5	126	1.6	18.3	252	0.8	10.93			79.3	145	1.9	15.9	290	1.0	12.60		75.2	153	1.8	15.0	306	0.9	13.30		65.4	176	1.8	13.1	353	0.9	15.30		54.9	210	1.5	11.0	420	0.8	18.21		52.0	222	1.4	10.4	443	0.7	19.24		47.3	244	1.3	9.5	487	0.7	21.15																																																																																																																																																																																																																																																																																																																																																																																																																																																																																																																																																																																																																																																																																																																																																																																																																		
	79.3	145	1.9	15.9	290	1.0	12.60			75.2	153	1.8	15.0	306	0.9	13.30		65.4	176	1.8	13.1	353	0.9	15.30		54.9	210	1.5	11.0	420	0.8	18.21		52.0	222	1.4	10.4	443	0.7	19.24		47.3	244	1.3	9.5	487	0.7	21.15																																																																																																																																																																																																																																																																																																																																																																																																																																																																																																																																																																																																																																																																																																																																																																																																																										
	75.2	153	1.8	15.0	306	0.9	13.30			65.4	176	1.8	13.1	353	0.9	15.30		54.9	210	1.5	11.0	420	0.8	18.21		52.0	222	1.4	10.4	443	0.7	19.24		47.3	244	1.3	9.5	487	0.7	21.15																																																																																																																																																																																																																																																																																																																																																																																																																																																																																																																																																																																																																																																																																																																																																																																																																																		
	65.4	176	1.8	13.1	353	0.9	15.30			54.9	210	1.5	11.0	420	0.8	18.21		52.0	222	1.4	10.4	443	0.7	19.24		47.3	244	1.3	9.5	487	0.7	21.15																																																																																																																																																																																																																																																																																																																																																																																																																																																																																																																																																																																																																																																																																																																																																																																																																																										
	54.9	210	1.5	11.0	420	0.8	18.21		52.0	222	1.4	10.4	443	0.7	19.24		47.3	244	1.3	9.5	487	0.7	21.15																																																																																																																																																																																																																																																																																																																																																																																																																																																																																																																																																																																																																																																																																																																																																																																																																																																			
	52.0	222	1.4	10.4	443	0.7	19.24		47.3	244	1.3	9.5	487	0.7	21.15																																																																																																																																																																																																																																																																																																																																																																																																																																																																																																																																																																																																																																																																																																																																																																																																																																																											
	47.3	244	1.3	9.5	487	0.7	21.15																																																																																																																																																																																																																																																																																																																																																																																																																																																																																																																																																																																																																																																																																																																																																																																																																																																																			

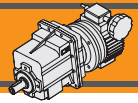

Dati tecnici

Technical data

P ₁ [kW]	velocità massima max speed			velocità minima min speed			i	
	n ₂ [min ⁻¹]	M ₂ [Nm]	sf	n ₂ [min ⁻¹]	M ₂ [Nm]	sf		

P ₁ [kW]	velocità massima max speed			velocità minima min speed			i	
	n ₂ [min ⁻¹]	M ₂ [Nm]	sf	n ₂ [min ⁻¹]	M ₂ [Nm]	sf		

2.2

90L2 n ₁ =2800 [min ⁻¹]	62.2	278	2.9	12.4	740	1.4	32.13	CMGV 052/15
	43.2	400	2.0	8.6	1067	1.0	46.31	
	35.7	474	1.7	7.1	1264	0.8	56.05	CMGV 053/15
	31.0	545	1.5	6.2	1455	0.7	64.48	
	26.7	634	1.3	5.3	1691	0.6	74.96	
	24.7	686	1.2	4.9	1829	0.6	81.07	
100LA4 n ₁ =1400 [min ⁻¹]	267	65	4.0	53.4	129	2.0	3.74	CMGV 042/22
	222	78	3.3	44.4	156	1.7	4.50	
	182	95	2.7	36.5	190	1.4	5.48	
	159	109	2.7	31.7	218	1.4	6.31	
	126	137	2.1	25.2	274	1.1	7.93	
	110	157	2.0	22.0	314	1.0	9.08	
	91.5	189	1.7	18.3	378	0.9	10.93	
	79.3	218	1.8	15.9	436	0.9	12.60	
	75.2	230	1.7	15.0	460	0.9	13.30	
	65.4	264	1.8	13.1	529	0.9	15.30	
	54.9	315	1.5	11.0	629	0.8	18.21	
	52.0	332	1.4	10.4	665	0.7	19.24	
	109.2	158	3.6	21.8	317	1.9	9.16	CMGV 052/22
	101.0	171	3.3	20.2	342	1.7	9.90	
	85.9	201	3.5	17.2	402	1.8	11.64	
	75.5	229	3.1	15.1	458	1.6	13.25	
70.9	244	3.4	14.2	488	1.8	14.11		
61.7	280	3.0	12.3	560	1.5	16.20		
49.2	351	2.4	9.8	702	1.2	20.31		
41.6	415	2.4	8.3	830	1.2	24.02		
31.1	555	1.8	6.2	1110	0.9	32.13		
21.6	800	1.3	4.3	1601	0.6	46.31		

3

100LB4 n ₁ =1400 [min ⁻¹]	265	87	5.3	52.9	174	2.7	3.78	CMGV 052/40
	208	111	4.2	41.7	221	2.1	4.80	
	172	134	3.4	34.4	268	1.8	5.82	
	150	154	3.4	29.9	308	1.8	6.68	
	119	193	2.7	23.9	386	1.4	8.37	
	109	211	2.7	21.8	422	1.4	9.16	
	101	228	2.5	20.2	456	1.3	9.90	
	85.9	268	2.6	17.2	536	1.4	11.64	
	75.5	305	2.3	15.1	610	1.2	13.25	
	70.9	325	2.6	14.2	650	1.3	14.11	
	61.7	373	2.3	12.3	746	1.2	16.20	
	49.2	468	1.8	9.8	936	0.9	20.31	
	41.6	553	1.8	8.3	1107	0.9	24.02	
	31.1	740	1.4	6.2	1480	0.7	32.13	

4

112M4 n ₁ =1400 [min ⁻¹]	267	115	2.2	53.4	230	1.2	3.74	CMGV 042/40	
	222	138	1.9	44.4	277	1.0	4.50		
	182	168	1.5	36.5	337	0.8	5.48		
	159	194	1.5	31.7	388	0.8	6.31		
	126	244	1.2	25.2	487	0.6	7.93		
	110	279	1.1	22.0	558	0.6	9.08		
	265	116	4.0	52.9	232	2.0	3.78		CMGV 052/40
	208	147	3.1	41.7	295	1.6	4.80		
	172	179	2.6	34.4	358	1.3	5.82		
	150	205	2.6	29.9	410	1.3	6.68		
	119	257	2.0	23.9	514	1.1	8.37		
	109	281	2.0	21.8	563	1.0	9.16		
	101	304	1.9	20.2	608	1.0	9.90		
	85.9	358	2.0	17.2	715	1.0	11.64		
	75.5	407	1.7	15.1	814	0.9	13.25		
	70.9	434	1.9	14.2	867	1.0	14.11		
61.7	498	1.7	12.3	995	0.9	16.20			
49.2	624	1.3	9.8	1248	0.7	20.31			
41.6	738	1.4	8.3	1476	0.7	24.02			

3

100LB4 n ₁ =1400 [min ⁻¹]	267	86	3.0	53.4	172	1.5	3.74	CMGV 042/40
	222	104	2.5	44.4	208	1.3	4.50	
	182	126	2.0	36.5	253	1.0	5.48	
	159	145	2.0	31.7	291	1.0	6.31	
	126	183	1.6	25.2	365	0.8	7.93	
	110	209	1.5	22.0	418	0.8	9.08	
	91.5	252	1.2	18.3	503	0.6	10.93	
	79.3	290	1.3	15.9	581	0.7	12.60	
	75.2	306	1.3	15.0	613	0.7	13.30	
	65.4	353	1.3	13.1	705	0.7	15.30	
	54.9	420	1.1	11.0	839	0.6	18.21	

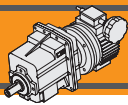

Dimensioni

Dimensions

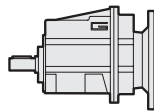

CMG

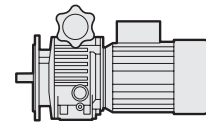

VAM

CMG	A	B	I	j1	LM	Albero uscita / Output shaft				
						D ₂ h6	E ₂	F ₂	G ₂	T ₂
002	92	81.5	0	44	143 ¹⁾ 153 ²⁾	16	40	5	M6	18
012	124	93	6.5	45	195	20	40	6	M6	22.5
013		112	43		268					
022	124	98	11.5	45	205	25	50	8	M8	28
023		117	48		278					
032	156	118	5	70	237	30	60	8	M10	33
033			41.5		303					
042	156	128	15	70	250	35	70	10	M12	38
043			51.5		316					
052	190	157	20	88	307.5	40	80	12	M16	43
053			68		380					

	VAM							
	G	G3	VC	VF	VL	VR	VR1	VS
018	112.5	64.5	71	111	78	110	110	85
037	110	74	71	123	90	110	110	85
075	139	85.5	79	140	107	120	120	85
15	188	115	—	144	122	120	120	85
22	208	131	—	188	150	160	—	110
40	208	131	—	188	150	160	—	110

¹⁾ IEC 63/71, ²⁾ IEC 80

Versione U / U Version						
CMG	H	K	L	M	N f7	O
002	2.5	11	78	64	50	n°5 M6x14
012 013	8.5	13.5	95	76	60	n°4 M8x15
022 023	8.5	13.5	95	76	60	n°4 M8x15
032 033	9	15	127	110	90	n°6 M8x19
042 043	9	15	127	110	90	n°6 M8x19
052 053	10	16	160	135	110	n°6 M10x22

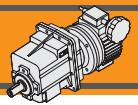

Dimensioni

Dimensions

CMGV..U

CMGV..2 U

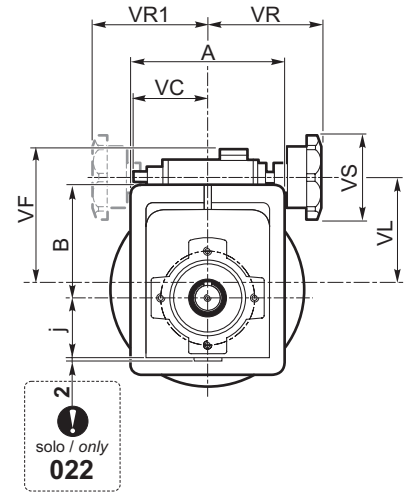
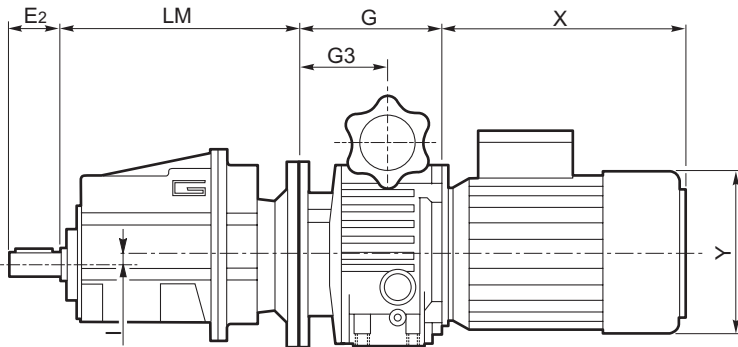

CMGV..3 U

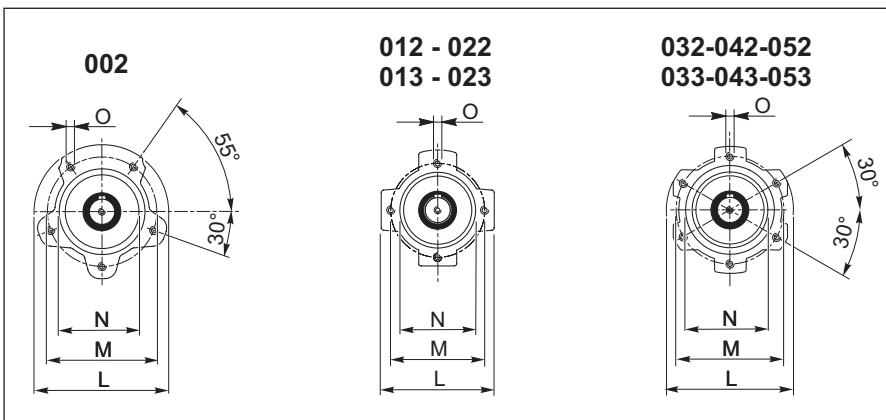
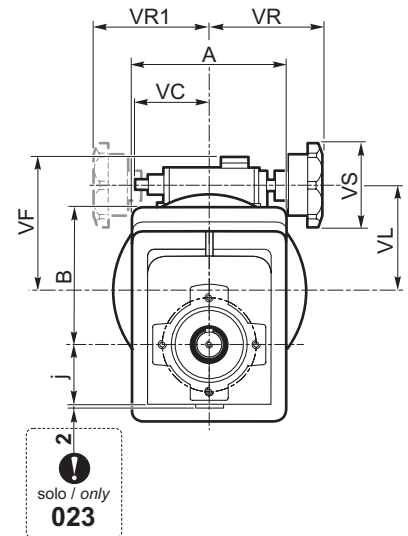
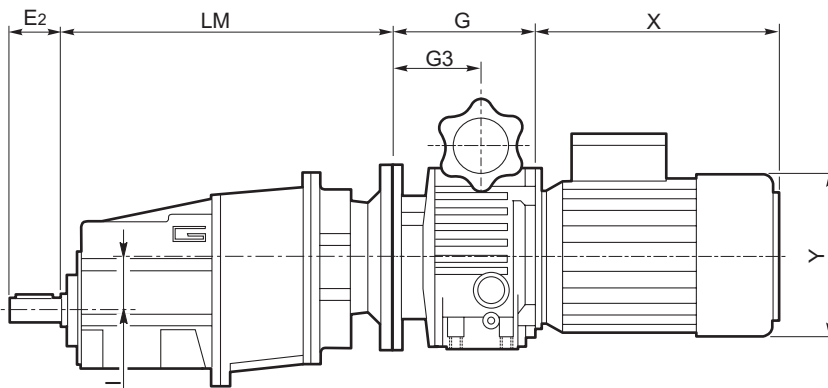

Albero uscita / Output shaft

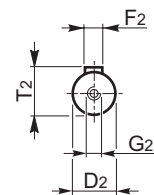

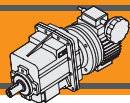

Dimensioni

Dimensions

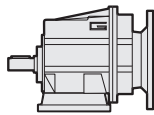

CMG

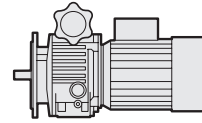

VAM

CMG	A	B	I	LM	Albero uscita / Output shaft				
					D ₂ h6	E ₂	F ₂	G ₂	T ₂
002	92	81.5	0	143 ¹⁾ 153 ²⁾	16	40	5	M6	18
012	124	93	6.5	195	20	40	6	M6	22.5
013		112	43	268					
022	124	98	11.5	205	25	50	8	M8	28
023		117	48	278					
032	156	118	5	237	30	60	8	M10	33
033			41.5	303					
042	156	128	15	250	35	70	10	M12	38
043			51.5	316					
052	190	157	20	307.5	40	80	12	M16	43
053			68	380					

	VAM							
	G	G3	VC	VF	VL	VR	VR1	VS
018	112.5	64.5	71	111	78	110	110	85
037	110	74	71	123	90	110	110	85
075	139	85.5	79	140	107	120	120	85
15	188	115		144	122	120	120	85
22	208	131		188	150	160		110
40	208	131		188	150	160		110

¹⁾ IEC 63/71, ²⁾ IEC 80

Versione H / H Version										
CMG	P	Q	R	S	U	V	X	Z	Piede / Foot	
									Tipo / Type	Peso / Weight [kg]
002	18	60	80	9	100	10	60	120	H60	0.2
	18	80	104	9	110 - 120	10	75	145	H75	0.3
	18	50 - 87	110	9	110	10	85	135	H85	0.4
012 013	20	85	108	9	115	12	65	139	H65	0.7
	18	80	118	9	110	12	75	140	H75	1.0
	25	85	120	9	120	12	80	140	H80	1.1
	18	50 - 87	118	9	110	12	85	130	H85	1.2
	25	130	154	9	110	12	90	135	H90	1.5
	18	50 - 107.5	135	11	130	12	100	155	H100	1.7
022 023	20	85	108	9	115	12	65	139	H65	0.7
	18	80	118	9	110	12	75	140	H75	1.0
	25	85	120	9	120	12	80	140	H80	1.1
	18	50 - 87	118	9	110	12	85	130	H85	1.2
	25	130	154	9	110	12	90	135	H90	1.5
	18	50 - 107.5	135	11	130	12	100	155	H100	1.7
032 033	30	105	136	14	160	14	95	194	H95	1.5
	30	100	150	11	150	14	110	185	H110	1.9
	18	70			160					
	30	165	195	14	135	14	115	170	H115	2.2
	35	110	160	14	170	14	120	210	H120	2.6
042 043	30	105	136	14	160	14	95	194	H95	1.5
	30	100	150	11	150	14	110	185	H110	1.9
	18	70			160					
	30	165	195	14	135	14	115	170	H115	2.2
	35	110	160	14	170	14	120	210	H120	2.6
052 053	35	145	200	18	200	22	120	239	H120	3.5
	35	205	244	18	170	22	140	219	H140	4.3
	25	110	199	18	225	22	155	264	H155	5.1
	156									

Preferenziale / Preferred

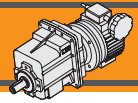

Dimensioni

Dimensions

CMGV..H

CMGV..2 H..

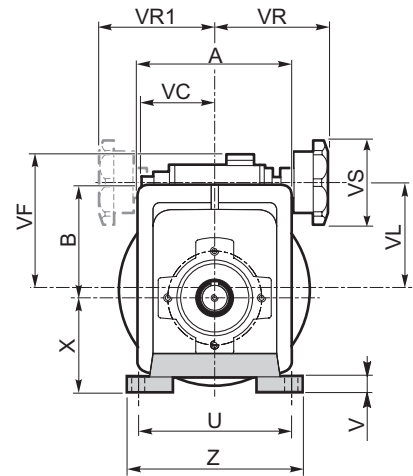
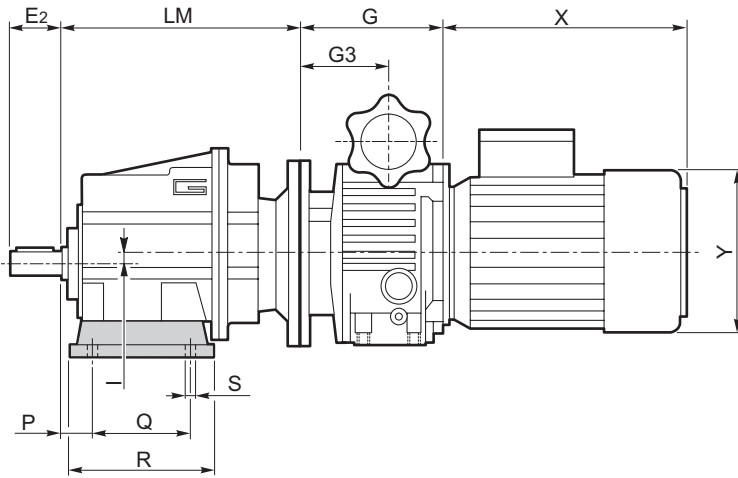

CMGV..3 H..

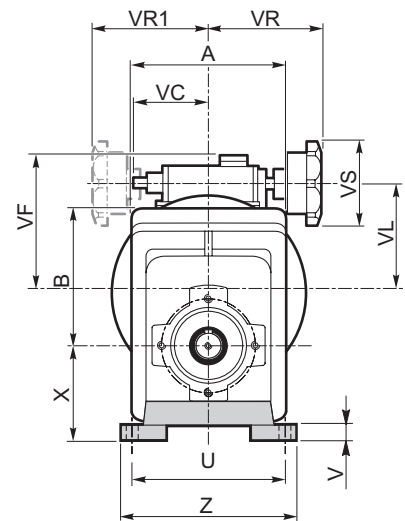
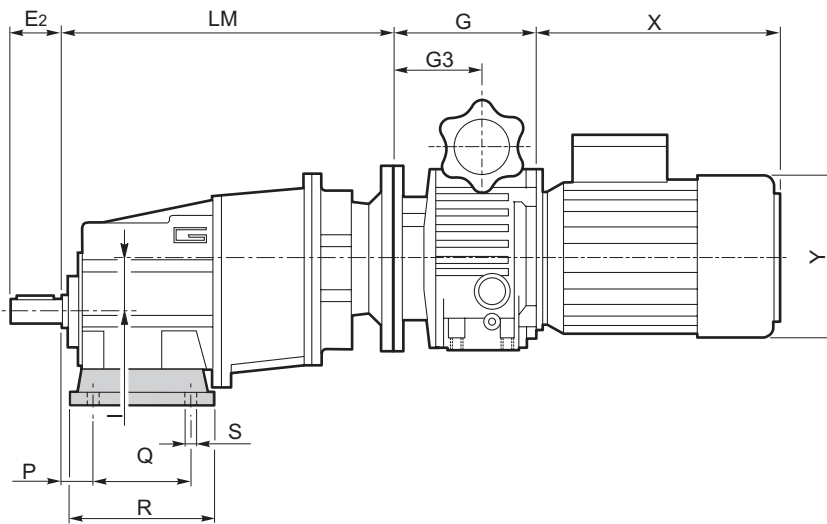

Albero uscita / Output shaft

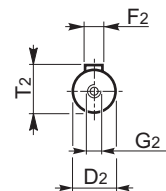

CMGV

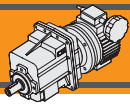

Dimensioni

Dimensions

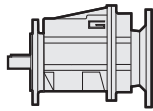

CMG

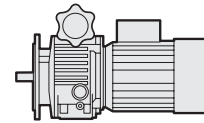

VAM

CMG	A	B	I	LM	Albero uscita / Output shaft				
					D ₂ h6	E ₂	F ₂	G ₂	T ₂
002	92	81.5	0	143 ¹⁾ 153 ²⁾	16	40	5	M6	18
012	124	93	6.5	195	20	40	6	M6	22.5
013		112	43	268					
022	124	98	11.5	205	25	50	8	M8	28
023		117	48	278					
032	156	118	5	237	30	60	8	M10	33
033			41.5	303					
042	156	128	15	250	35	70	10	M12	38
043			51.5	316					
052	190	157	20	307.5	40	80	12	M16	43
053			68	380					

	VAM							
	G	G3	VC	VF	VL	VR	VR1	VS
018	112.5	64.5	71	111	78	110	110	85
037	110	74	71	123	90	110	110	85
075	139	85.5	79	140	107	120	120	85
15	188	115		144	122	120	120	85
22	208	131		188	150	160		110
40	208	131		188	150	160		110

¹⁾ IEC 63/71, ²⁾ IEC 80

Versione F / F Version									
CMG	H	K	L	M	N f7	O	P	Flangia / Flange	
								Tipo / Type	Peso / Weight [kg]
002	3.5	7	105	85	70	6.5	90	F105	0.1
	3.5	8	120	100	80	7	100	F120	0.2
	3.5	8	140	115	95	9	115	F140	0.2
012 013	3	9	120	100	80	9	106	F120	0.5
	3.5	9	140	115	95	9	115	F140	0.8
	3.5	9	160	130	110	9	126	F160	1.1
	3.5	11	200	165	130	11	165	F200	1.8
022 023	3	9	120	100	80	9	106	F120	0.5
	3.5	9	140	115	95	9	115	F140	0.8
	3.5	9	160	130	110	9	126	F160	1.1
	3.5	11	200	165	130	11	165	F200	1.8
032 033	3.5	11	160	130	110	9	140	F160	1.0
	3.5	11	200	165	130	11	165	F200	1.8
	4	13	250	215	180	14	215	F250	2.9
042 043	3.5	11	160	130	110	9	140	F160	1.0
	3.5	11	200	165	130	11	165	F200	1.8
	4	13	250	215	180	14	215	F250	2.9
052 053	4	13	250	215	180	14	215	F250	2.9
	4	13	300	265	230	14	265	F300	4.4

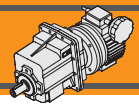

Dimensioni

Dimensions

CMGV..F

CMGV..2 F..

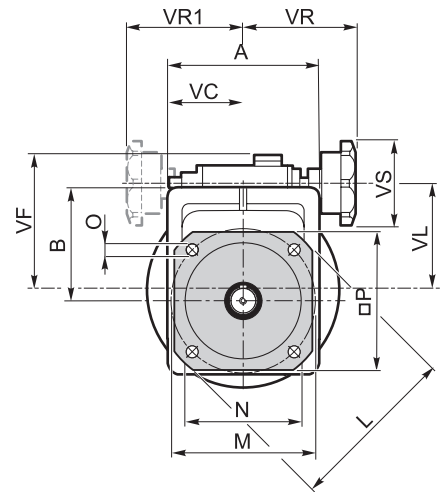
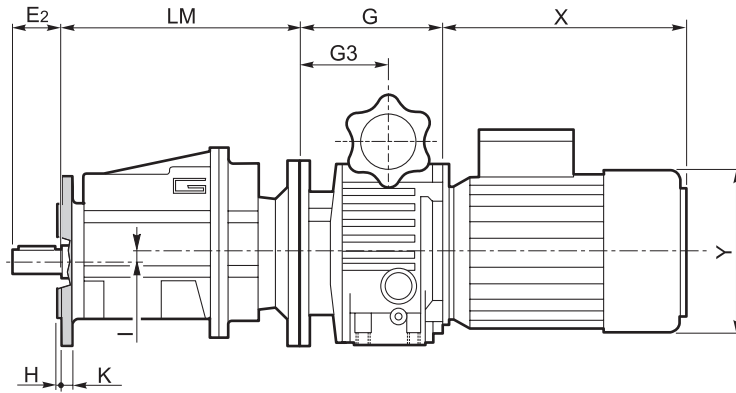

CMGV..3 F..

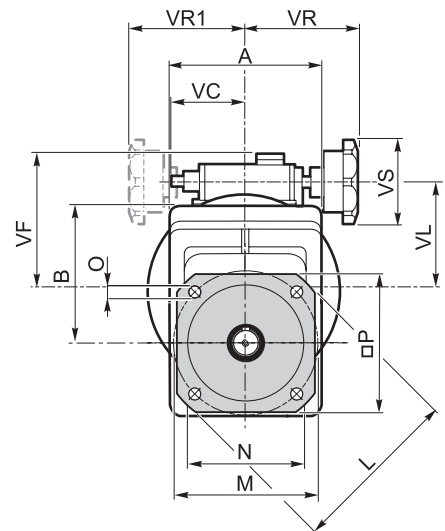
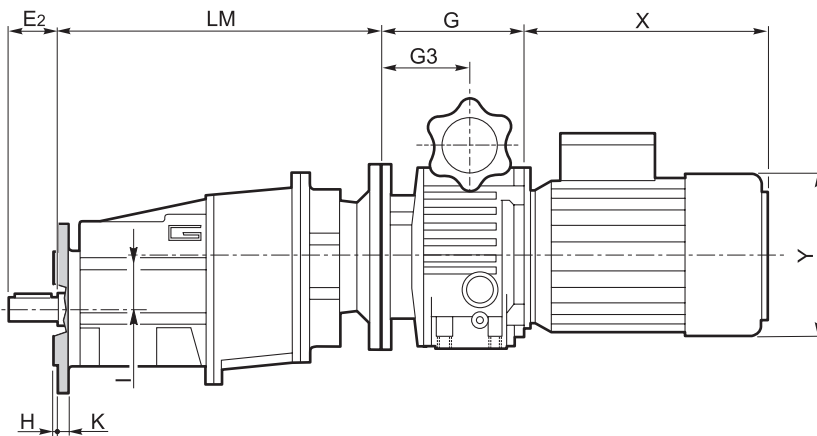

Albero uscita / Output shaft

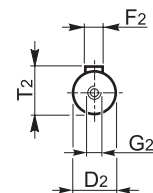

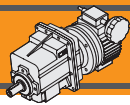

Dimensioni

Dimensions

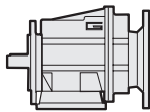

CMG

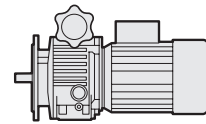

VAM

CMG	A	B	I	LM	Albero uscita / Output shaft				
					D ₂ h6	E ₂	F ₂	G ₂	T ₂
002	92	81.5	0	143 ¹⁾ 153 ²⁾	16	40	5	M6	18
012	124	93	6.5	195	20	40	6	M6	22.5
013		112	43	268					
022	124	98	11.5	205	25	50	8	M8	28
023		117	48	278					
032	156	118	5	237	30	60	8	M10	33
033			41.5	303					
042	156	128	15	250	35	70	10	M12	38
043			51.5	316					
052	190	157	20	307.5	40	80	12	M16	43
053			68	380					

	VAM							
	G	G3	VC	VF	VL	VR	VR1	VS
018	112.5	64.5	71	111	78	110	110	85
037	110	74	71	123	90	110	110	85
075	139	85.5	79	140	107	120	120	85
15	188	115		144	122	120	120	85
22	208	131		188	150	160		110
40	208	131		188	150	160		110

1) IEC 63/71, 2) IEC 80

Versione H / H Version										Combinazioni possibili H/F Possible assembling H/F							
CMG	P	Q	R	S	U	V	X	Z	Piede / Foot		F105	F120	F140	F160	F200	F250	F300
									Tipo Type	Peso [kg] Weight [kg]							
002	18	60	80	9	100	10	60	120	H60	0.2	•	•	•				
	18	80	104	9	110-120	10	75	145	H75	0.3	•	•	•				
	18	50 - 87	110	9	110	10	85	135	H85	0.4	•	•	•				
012 013	20	85	108	9	115	12	65	139	H65	0.7		•	•				
	18	80	118	9	110	12	75	140	H75	1.0		•	•	•			
	25	85	120	9	120	12	80	140	H80	1.1		•	•	•			
	18	50 - 87	118	9	110	12	85	130	H85	1.2		•	•	•			
	25	130	154	9	110	12	90	135	H90	1.5		•	•	•	•		
022 023	20	85	108	9	115	12	65	139	H65	0.7		•	•				
	18	80	118	9	110	12	75	140	H75	1.0		•	•	•			
	25	85	120	9	120	12	80	140	H80	1.1		•	•	•			
	18	50 - 87	118	9	110	12	85	130	H85	1.2		•	•	•			
	25	130	154	9	110	12	90	135	H90	1.5		•	•	•	•		
032 033	30	105	136	14	160	14	95	194	H95	1.5				•	•		
	30	100	150	11	150	14	110	185	H110	1.9				•	•		
	18	70			160												
	30	165	195	14	135	14	115	170	H115	2.2				•	•	•	
	35	110	160	14	170	14	120	210	H120	2.6				•	•	•	
042 043	30	105	136	14	160	14	95	194	H95	1.5				•	•		
	30	100	150	11	150	14	110	185	H110	1.9				•	•		
	18	70			160												
	30	165	195	14	135	14	115	170	H115	2.2				•	•	•	
35	110	160	14	170	14	120	210	H120	2.6				•	•	•		
052 053	35	145	199	18	200	22	120	239	H120	3.5						•	
	35	205	244	18	170	22	140	219	H140	4.3						•	•
	25	110	199	18	225	22	155	264	H155	5.1						•	•
	156																

Preferenziale / Preferred

• Combinazioni possibili H/F / Possible assembling H/F

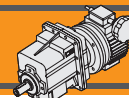

Dimensioni

Dimensions

CMGV..H/F

CMGV..2 H../F..

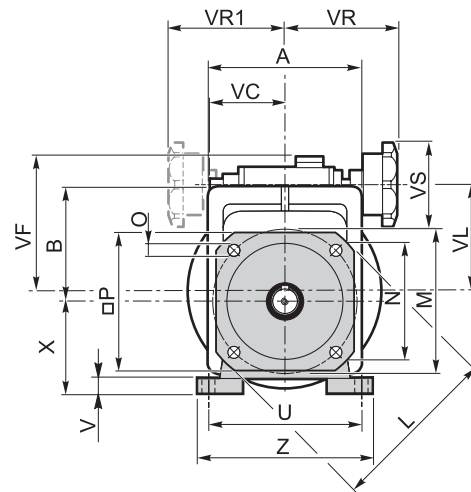
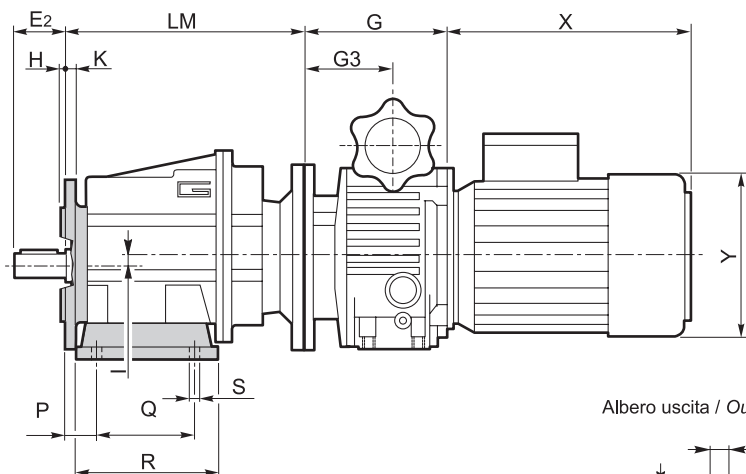

Albero uscita / Output shaft

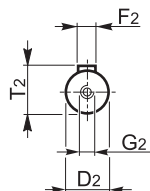

CMGV..3 H../F..

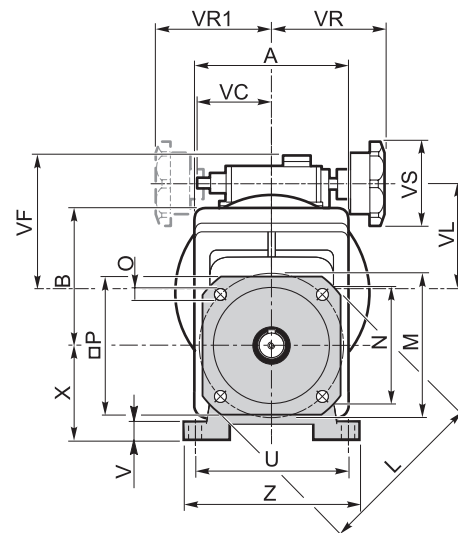
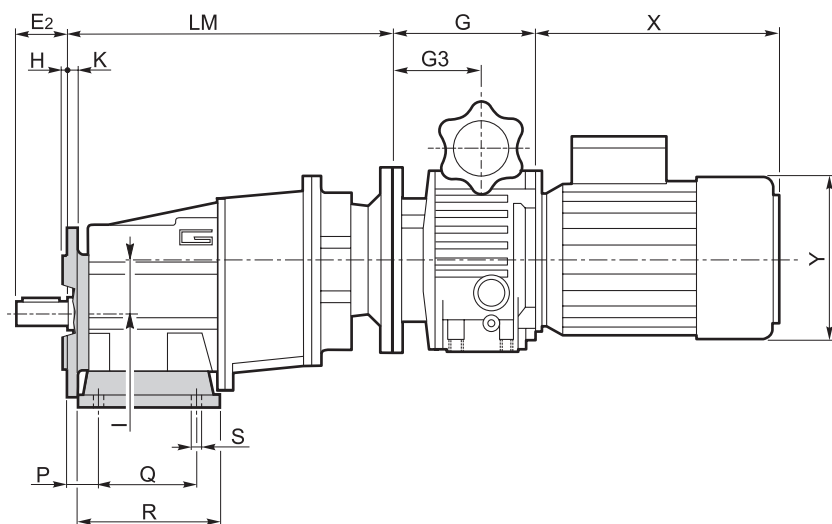

Versione F / F Version

CMG	H	K	L	M	N f7	O	P	Flangia / Flange	
								Tipo / Type	Peso / Weight [kg]
002	3.5	7	105	85	70	6.5	90	F105	0.1
	3.5	8	120	100	80	7	100	F120	0.2
	3.5	8	140	115	95	9	115	F140	0.2
012 013	3	9	120	100	80	9	106	F120	0.5
	3.5	9	140	115	95	9	115	F140	0.8
	3.5	9	160	130	110	9	126	F160	1.1
022 023	3.5	11	200	165	130	11	165	F200	1.8
	3	9	120	100	80	9	106	F120	0.5
	3.5	9	140	115	95	9	115	F140	0.8
032 033	3.5	9	160	130	110	9	126	F160	1.1
	3.5	11	200	165	130	11	165	F200	1.8
	4	13	250	215	150	14	215	F250	2.9
042 043	3.5	11	160	130	110	9	140	F160	1.0
	3.5	11	200	165	130	11	165	F200	1.8
	4	13	250	215	150	14	215	F250	2.9
052 053	4	13	250	215	150	14	215	F250	2.9
	4	13	300	265	230	14	265	F300	4.4

CMGV