

www.dutchi.com
dutchi.motors@dutchi.nl

QUALITY SYSTEM CERTIFICATION

Dutchi Motors B.V.

van Oldebarneveldtstraat 85A
NL - 6828 ZN ARNHEM

This is to certify that the range of Dutchi Motors®

Three phase asynchronous squirrel cage motors series :

DMA2 , frame size 56 till 132

DM1 , frame size 80 till 400

DM1-HV , frame size 355 till 630

are manufactured according the Quality System which is in conformity with :

- Certification Standard : ISO 9001 : 1994

Certification scope :

**Design, Development, Production and service of Middle-small size
electric motors series DMA2 & DM1**

Certificate number : **3200 / 20005761**

Date of Issue : **17 November 2000**

Valid Until : **16 November 2003**

Arnhem, 23-09-2003

Dutchi Motors B.V.

dr. T. Bienemann MBA President

This certificate attests to the conformity with the named quality certification, however, it is not a guarantee of properties in the meaning of product liability.

20030923

DM1-HV : 2 - Pole; Polig; Pôles; Polos - 3000 min⁻¹

DM1-HV Medium & High Voltage IP55 Motors

Dutchi Motors[®] medium & high voltage, in cast iron, three phase, Totally Enclosed Fan Cooled motor, SKF/NSK bearings.

Insulation class F, IP55. Voltage : 3KV, 3.3KV, 6KV, 6.6KV, 50HZ / 60HZ, take advantage of high efficiency and low noise level !

DUTCHI MOTOR type DM1-HV = cast iron series 1, Medium & High Voltage frame size Baugröße hauteur d'axe tamaño de carcassa IEC-DIN	rated output power	Rated current at		full-load speed rpm	full-load power factor	full-load efficiency	Starting current I _s /I _N	Starting torque M _s /M _N	Pull-out torque M _v /M _N	Moment of inertia J = 1/4GD ²	Weight foot mounted
	Nenn-Leistung	Nennstrom bei		Nenn-drehzahl min ⁻¹	Leistungs-faktor	Wirkungs-grad	Anlaufstrom I _s /I _N	Anlauf-moment M _s /M _N	Kipp-zu Nennmoment M _v /M _N	Trägheits-moment J = 1/4GD ²	Gewicht Fußaus-führung
	Puissance Nominal	Courant nominale à		Vitesse nominale t/min	Facteur de puissance	Rendement	Courant de démarrage I _d /I _N	Couple de démarrage C _d /C _N	Couple maximum C _m /C _N	Moment d'inertie J = 1/4GD ²	Masse (moteur à pattes)
	Potencia Nominal	Intensidad nominal à		Velocidad nominal r/min	Factor de potencia	Rendimiento	Intensidad de arranque I _s /I _N	Par de arranque T _s /T _N	Par maximal T _{max} /T _N	Momento de inercia J = 1/4GD ²	Peso (motor con patas)
	P _N kW		6000 V I _N A	n _N min ⁻¹	cos φ	100% η %				kgm ²	kg
DM1-HV 355 M 2											
DM1-HV 355 MX 2	160										
DM1-HV 355 MY 2	185	22,60	2.980	0,84	93,9	7,0	0,7	2,0	2,400	1.800	
DM1-HV 355 L 2	200	24,40	2.980	0,84	94,0	7,0	0,7	2,0	2,600	1.900	
DM1-HV 355 LX 2	220	26,80	2.980	0,84	94,2	7,0	0,7	2,0	2,700	2.000	
DM1-HV 355 LY 2	250	30,30	2.980	0,84	94,4	7,0	0,7	2,0	3,000	2.100	
DM1-HV 355 LZ 2	280	33,10	2.980	0,86	94,6	7,0	0,7	2,0	3,300	2.200	
DM1-HV 400 M 2	315		37,10	2.980	0,86	94,8	7,0	0,7	2,0	4,500	2.800
DM1-HV 400 MX 2	355		41,90	2.980	0,86	95,1	7,0	0,7	2,0	5,000	2.900
DM1-HV 400 L 2	400		47,00	2.980	0,86	95,2	7,0	0,7	2,0	5,500	3.000
DM1-HV 400 LX 2	450		52,80	2.980	0,86	94,6	7,0	0,7	2,0	6,000	3.100
DM1-HV 400 LY 2											
DM1-HV 400 LZ 2											
DM1-HV 450 M 2	500		58,00	2.975	0,87	95,3	7,0	0,7	2,0	10,000	3.400
DM1-HV 450 MX 2	560		64,90	2.975	0,87	95,4	7,0	0,7	2,0	11,000	3.500
DM1-HV 450 L 2	630		72,90	2.975	0,87	95,5	7,0	0,7	2,0	12,000	3.600
DM1-HV 450 LX 2	710		82,00	2.975	0,87	95,7	7,0	0,7	2,0	13,000	3.700
DM1-HV 450 LY 2											
DM1-HV 500 M 2	800		91,50	2.980	0,88	95,6	7,0	0,7	2,0	16,000	4.300
DM1-HV 500 MX 2	900		102,8	2.980	0,88	95,7	7,0	0,7	2,0	17,000	4.400
DM1-HV 500 L 2	1.000		114,0	2.980	0,88	95,9	7,0	0,7	2,0	18,000	4.600
DM1-HV 500 LX 2	1.120		127,5	2.980	0,88	96,0	7,0	0,7	2,0	19,000	4.800
DM1-HV 500 LY 2											
DM1-HV 560 M 2	1.250		140,6	2.980	0,89	96,1	7,0	0,7	2,0	30,000	5.200
DM1-HV 560 MX 2	1.400		157,1	2.980	0,89	96,3	7,0	0,7	2,0	35,000	5.700
DM1-HV 560 L 2	1.600		179,2	2.980	0,89	96,5	7,0	0,7	2,0	40,000	6.200
DM1-HV 560 LX 2	1.800										

DM1-HV : 4 - Pole; Polig; Pôle; Polos - 1500 min⁻¹

DM1-HV Medium & High Voltage IP55 Motors

Dutchi Motors[®] medium & high voltage, in cast iron, three phase, Totally Enclosed Fan Cooled motor, SKF/NSK bearings.

Insulation class F, IP55. Voltage : 3KV, 3.3KV, 6KV, 6.6KV, 50HZ / 60HZ, take advantage of high efficiency and low noise level !

DUTCHI MOTOR type DM1-HV = cast iron series 1, Medium & High Voltage frame size Baugröße hauteur d'axe tamaño de carcassa IEC-DIN	rated output power	Rated current at		full-load speed rpm	full-load power factor	full-load efficiency	Starting current	Starting torque	Pull-out torque	Moment of inertia	Weight foot mounted
	Nenn-Leistung	Nennstrom bei		Nenn-drehzahl min ⁻¹	Leistungs-faktor	Wirkungs-grad	Anlaufstrom	Anlauf-moment	Kipp-zu	Trägheits-moment	Gewicht
	Puissance Nominale	Courant nominale à		Vitesse nominale t/min	Facteur de puissance	Rendement	Courant de démarrage	Couple de démarrage	Couple maximum	Moment d'inertie	Masse (moteur à pattes)
	Potencia Nominale	Intensidad nominal à		Velocidad nominal r/min	Factor de potencia	Rendimiento	Intensidad de arranque	Par de arranque	Par maximal	Momento de inercia	Peso (motor con patas)
	P _N kW	6000 V	I _N A	n _N min ⁻¹	cos φ	100%	η %				kgm ²
DM1-HV 355 M 4											
DM1-HV 355 MX 4	160										
DM1-HV 355 MY 4	185	22,60	1.480	0,84	93,7	6,5	0,8	2,0	5,000	1.800	
DM1-HV 355 L 4	200	24,30	1.480	0,84	93,9	6,5	0,8	2,0	6,000	1.900	
DM1-HV 355 LX 4	220	26,70	1.480	0,84	94,1	6,5	0,8	2,0	7,000	2.000	
DM1-HV 355 LY 4	250	30,30	1.480	0,84	94,3	6,5	0,8	2,0	8,000	2.100	
DM1-HV 355 LZ 4	280	33,90	1.480	0,84	94,5	6,5	0,8	2,0	9,000	2.200	
DM1-HV 400 M 4	315	37,60	1.485	0,85	94,6	6,5	0,8	2,0	10,000	2.900	
DM1-HV 400 MX 4	355	42,30	1.485	0,85	94,8	6,5	0,8	2,0	11,000	3.000	
DM1-HV 400 L 4	400	47,60	1.485	0,85	95,0	6,5	0,8	2,0	12,000	3.100	
DM1-HV 400 LX 4	450	53,50	1.485	0,85	95,2	6,5	0,8	2,0	13,000	3.200	
DM1-HV 400 LY 4											
DM1-HV 400 LZ 4											
DM1-HV 450 M 4	500	58,70	1.485	0,86	95,3	6,5	0,8	2,0	20,000	3.500	
DM1-HV 450 MX 4	560	65,60	1.485	0,86	95,4	6,5	0,8	2,0	22,000	3.600	
DM1-HV 450 L 4	630	73,80	1.485	0,86	95,5	6,5	0,8	2,0	24,000	3.700	
DM1-HV 450 LX 4	710	83,60	1.485	0,86	95,6	6,5	0,8	2,0	26,000	3.800	
DM1-HV 450 LY 4											
DM1-HV 500 M 4	800	93,50	1.485	0,86	95,7	6,5	0,8	2,0	38,000	4.500	
DM1-HV 500 MX 4	900	105,1	1.485	0,86	95,8	6,5	0,8	2,0	41,000	4.700	
DM1-HV 500 L 4	1.000	116,6	1.485	0,86	95,8	6,5	0,8	2,0	44,000	5.200	
DM1-HV 500 LX 4	1.120	130,5	1.485	0,86	96,0	6,5	0,8	2,0	47,000	5.400	
DM1-HV 500 LY 4											
DM1-HV 560 M 4	1.250	143,8	1.490	0,87	96,1	6,5	0,7	2,0	65,000	5.600	
DM1-HV 560 MX 4	1.400	160,9	1.490	0,87	96,2	6,5	0,7	2,0	70,000	5.900	
DM1-HV 560 L 4	1.600	183,5	1.490	0,87	96,4	6,5	0,7	2,0	75,000	6.400	
DM1-HV 560 LX 4	1.800										

DM1-HV : 6 - Pole; Polig; Pôles; Polos - 1000 min⁻¹

DM1-HV Medium & High Voltage IP55 Motors

Dutchi Motors[®] medium & high voltage, in cast iron, three phase, Totally Enclosed Fan Cooled motor, SKF/NSK bearings.

Insulation class F, IP55. Voltage : 3KV, 3.3KV, 6KV, 6.6KV, 50HZ / 60HZ, take advantage of high efficiency and low noise level !

DUTCHI MOTOR type DM1-HV = cast iron series 1, Medium & High Voltage frame size Baugröße hauteur d'axe tamaño de carcassa IEC-DIN	rated output power	Rated current at		full-load speed rpm	full-load power factor	full-load efficiency	Starting current I _s /I _N	Starting torque M _s /M _N	Pull-out torque M _v /M _N	Moment of inertia J = 1/4GD ²	Weight foot mounted
	Nenn-Leistung	Nennstrom bei		Nenn-drehzahl min ⁻¹	Leistungs-faktor	Wirkungs-grad	Anlaufstrom I _s /I _N	Anlauf-moment M _s /M _N	Kipp-zu Nennmoment M _v /M _N	Trägheits-moment J = 1/4GD ²	Gewicht Fußaus-führung
	Puissance Nominal	Courant nominale à		Vitesse nominale t/min	Facteur de puissance	Rendement	Courant de démarrage I _d /I _N	Couple de démarrage C _d /C _N	Couple maximum C _m /C _N	Moment d'inertie J = 1/4GD ²	Masse (moteur à pattes)
	Potencia Nominal	Intensidad nominal à		Velocidad nominal r/min	Factor de potencia	Rendimiento	Intensidad de arranque I _s /I _N	Par de arranque T _s /T _N	Par maximal T _{max} /T _N	Momento de inercia J = 1/4GD ²	Peso (motor con patas)
	P _N kW		6000 V I _N A	n _N min ⁻¹	cos φ	100% η %				kgm ²	kg
DM1-HV 355 M 6											
DM1-HV 355 MX 6											
DM1-HV 355 MY 6	160	20,60	985	0,80	93,4	6,5	0,8	2,0	8,000	2.100	
DM1-HV 355 L 6	185	22,70	985	0,80	93,5	6,5	0,8	2,0	9,000	2.200	
DM1-HV 355 LX 6	200	25,70	985	0,80	93,6	6,5	0,8	2,0	10,000	2.300	
DM1-HV 355 LY 6											
DM1-HV 355 LZ 6											
DM1-HV 400 M 6	220	27,50	990	0,82	93,8	6,0	0,8	2,0	12,000	2.800	
DM1-HV 400 MX 6	250	31,20	990	0,82	93,9	6,0	0,8	2,0	14,000	2.900	
DM1-HV 400 L 6	280	34,90	990	0,82	94,1	6,0	0,8	2,0	16,000	3.000	
DM1-HV 400 LX 6	315	39,10	990	0,82	94,3	6,0	0,8	2,0	18,000	3.200	
DM1-HV 400 LY 6											
DM1-HV 400 LZ 6											
DM1-HV 450 M 6	355	43,50	985	0,83	94,5	6,0	0,8	2,0	26,000	3.400	
DM1-HV 450 MX 6	400	49,00	985	0,83	94,6	6,0	0,8	2,0	28,000	3.500	
DM1-HV 450 L 6	450	55,00	985	0,83	94,7	6,0	0,8	2,0	30,000	3.600	
DM1-HV 450 LX 6	500	61,00	985	0,83	94,9	6,0	0,8	2,0	32,000	3.700	
DM1-HV 450 LY 6											
DM1-HV 500 M 6	560	68,20	990	0,83	95,1	6,0	0,8	2,0	46,000	4.300	
DM1-HV 500 MX 6	630	76,70	990	0,83	95,2	6,0	0,8	2,0	50,000	4.500	
DM1-HV 500 L 6	710	86,30	990	0,83	95,3	6,0	0,8	2,0	58,000	4.700	
DM1-HV 500 LX 6	800	97,20	990	0,83	95,4	6,0	0,8	2,0	62,000	4.900	
DM1-HV 500 LY 6											
DM1-HV 560 M 6	900	107,8	990	0,84	95,6	6,0	0,7	2,0	90,000	5.200	
DM1-HV 560 MX 6	1.000	119,7	990	0,84	95,7	6,0	0,7	2,0	96,000	5.500	
DM1-HV 560 L 6	1.120	133,9	990	0,84	95,8	6,0	0,7	2,0	108,000	6.000	
DM1-HV 560 LX 6	1.250	140,3	990	0,84	95,9	6,0	0,7	2,0	114,000	6.300	

DM1-HV : 8 - Pole; Polig; Pôle; Polos - 750 min⁻¹

DM1-HV Medium & High Voltage IP55 Motors

Dutchi Motors[®] medium & high voltage, in cast iron, three phase, Totally Enclosed Fan Cooled motor, SKF/NSK bearings.

Insulation class F, IP55. Voltage : 3KV, 3.3KV, 6KV, 6.6KV, 50HZ / 60HZ, take advantage of high efficiency and low noise level !

DUTCHI MOTOR type DM1-HV = cast iron series 1, Medium & High Voltage frame size Baugröße hauteur d'axe tamaño de carcassa IEC-DIN	rated output power	Rated current at		full-load speed rpm	full-load power factor	full-load efficiency	Starting current	Starting torque	Pull-out torque	Moment of inertia	Weight foot mounted
	Nenn-Leistung	Nennstrom bei		Nenn-drehzahl min ⁻¹	Leistungs-faktor	Wirkungs-grad	Anlaufstrom	Anlauf-moment	Kipp-zu Nennmoment	Trägheits-moment	Gewicht Fußaus-führung
	Puissance Nominal	Courant nominale à		Vitesse nominale t/min	Facteur de puissance	Rendement	Courant de démarrage	Couple de démarrage	Couple maximum	Moment d'inertie	Masse (moteur à pattes)
	Potencia Nominal	Intensidad nominal à		Velocidad nominal r/min	Factor de potencia	Rendimiento	Intensidad de arranque	Par de arranque	Par maximal	Momento de inercia	Peso (motor con patas)
	P _N kW		6000 V I _N A	n _N min ⁻¹	cos φ	100% η %					kgm ²
DM1-HV 355 M 8	90 110 132										
DM1-HV 355 MX 8											
DM1-HV 355 MY 8											
DM1-HV 355 L 8											
DM1-HV 355 LX 8											
DM1-HV 355 LY 8											
DM1-HV 355 LZ 8											
DM1-HV 400 M 8	160		21,70	740	0,76	93,2	5,5	0,8	2,0	14,000	2.900
DM1-HV 400 MX 8	185		25,10	740	0,76	93,3	5,5	0,8	2,0	15,000	3.000
DM1-HV 400 L 8	200		26,70	740	0,77	93,5	5,5	0,8	2,0	16,000	3.100
DM1-HV 400 LX 8	220		29,30	740	0,77	93,7	5,5	0,8	2,0	18,000	3.200
DM1-HV 400 LY 8											
DM1-HV 400 LZ 8											
DM1-HV 450 M 8	250		32,80	740	0,78	93,9	5,5	0,8	2,0	26,000	3.400
DM1-HV 450 MX 8	280		36,70	740	0,78	94,4	5,5	0,8	2,0	28,000	3.500
DM1-HV 450 L 8	315		41,20	740	0,78	94,2	5,5	0,8	2,0	30,000	3.600
DM1-HV 450 LX 8	355		46,30	740	0,78	94,4	5,5	0,8	2,0	32,000	3.700
DM1-HV 450 LY 8											
DM1-HV 500 M 8	400		51,50	740	0,79	94,5	5,5	0,8	2,0	50,000	4.400
DM1-HV 500 MX 8	450		57,90	740	0,79	94,6	5,5	0,8	2,0	54,000	4.600
DM1-HV 500 L 8	500		63,40	740	0,80	94,8	5,5	0,8	2,0	58,000	4.800
DM1-HV 500 LX 8	560		70,90	740	0,80	94,9	5,5	0,8	2,0	62,000	4.900
DM1-HV 500 LY 8											
DM1-HV 560 M 8	630		78,60	740	0,81	95,1	5,5	0,7	2,0	90,000	5.400
DM1-HV 560 MX 8	710		88,50	740	0,81	95,3	5,5	0,7	2,0	102,000	5.700
DM1-HV 560 L 8	800		99,60	740	0,81	95,4	5,5	0,7	2,0	108,000	6.000
DM1-HV 560 LX 8	900		111,8	740	0,81	95,6	5,5	0,7	2,0	114,000	6.300

DM1-HV (IP55) 355 - 560 : IM B3

DM1-HV Medium & High Voltage IP55 Motors

Dutchi Motors[®] medium & high voltage, in cast iron, three phase, Totally Enclosed Fan Cooled motor, SKFINSK bearings.

Insulation class F, IP55. Voltage : 3KV, 3.3KV, 6KV, 6.6KV, 50HZ / 60HZ, take advantage of high efficiency and low noise level !

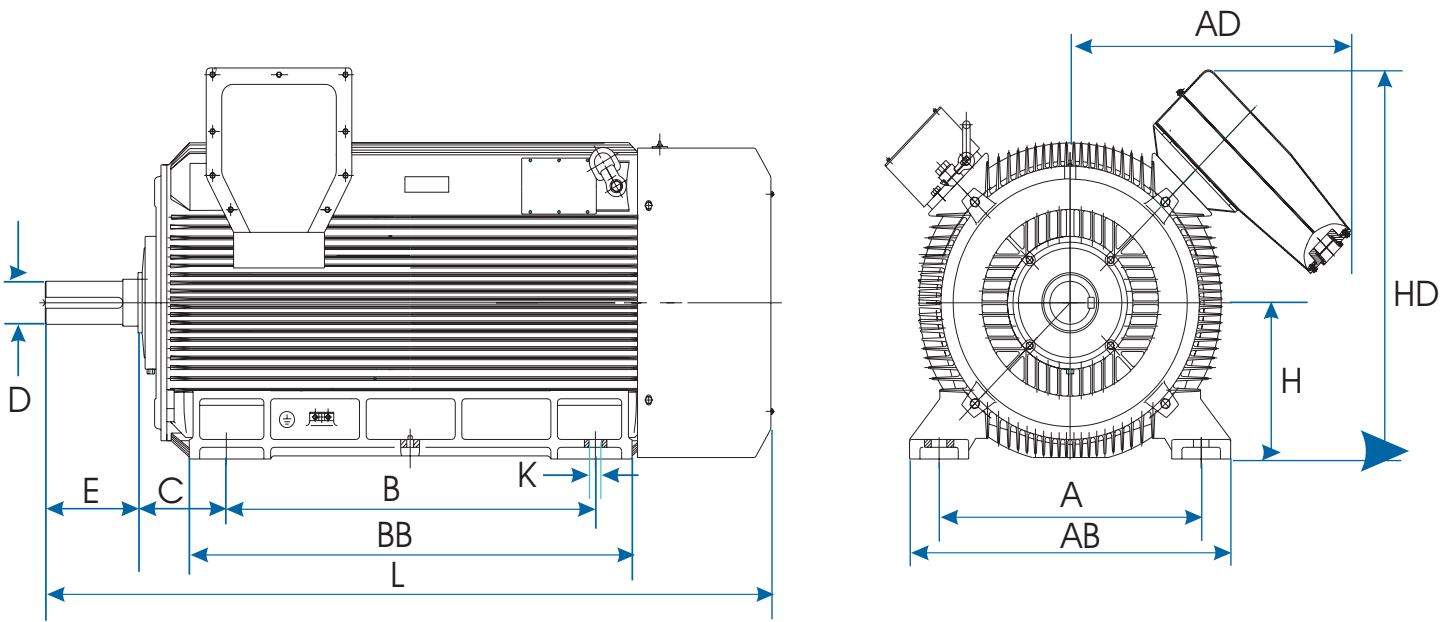

Dimensions in mm		Abmessungen in mm							Dimensions en mm				Dimensiones en mm			
Type		A	B	C	D	E	F	G	H	K	K1	AD	HD	AB	BB	L
DM1-HV	355 2	630	900	254	75m6	140	20	67,5	355	28	35	860	1250	790	1110	2000
	4 - 6				100m6	210	28	90								
DM1-HV	400 2	710	1000	280	85m6	170	22	76	400	35	42	880	1340	870	1200	2200
	4 - 6				110m6	210	28	100								
DM1-HV	450 2	800	1120	280	95m6	170	25	86	450	35	42	930	1300	950	1340	2310
	4				120m6	210	32	109								
	6 - 8				130m6	250		119								
DM1-HV	500 2	900	1250	315	110m6	210	28	100	500	42	50	970	1280	1080	1490	2610
	4				130m6	250	32	119								
	6 - 8				140m6		36	128								
DM1-HV	560 2	1000	1400	355	130m6	250	32	119	560	42	50	1030	1380	1180	1680	2900
	4				150m6		36	138								
	6 - 8				160m6	300	40	147								

DM1-HV-.. : IP55 & IP23 Voltage : 3KV, 3.3KV, 6KV, 6.6KV, 50HZ / 60HZ

DM1-HV Medium & High Voltage motors DM1-HV Medium & High Voltage motors IP55 with Air to Air cooler top mounted IP23 execution

DUTCHI MOTOR type DM1-HV = cast iron series 1, Medium & High Voltage frame size Baugröße hauteur d'axe tamaño de carcassa IEC-DIN	rated output power	rated output power	rated output power	rated output power
	2 - Pole; Polig; P.ôle; Polos - 3000 min ⁻¹	4 - Pole; Polig; P.ôle; Polos - 1500 min ⁻¹	6 - Pole; Polig; P.ôle; Polos - 1000 min ⁻¹	8 - Pole; Polig; P.ôle; Polos - 750 min ⁻¹
	P _N kW	P _N kW	P _N kW	P _N kW
DM1-HV-AA 355 M	220	220	220	
DM1-HV-AA 355 MX	250	250		
DM1-HV-AA 355 MY	280			
DM1-HV-AA 355 L	315	280	250	
DM1-HV-AA 355 LX	355	315		
DM1-HV-AA 355 LY	400			
DM1-HV-AA 355 LZ				
DM1-HV-AA 400 M	450	355	280	220
DM1-HV-AA 400 MX	500			
DM1-HV-AA 400 L	560	400	315	250
DM1-HV-AA 400 LX	630	450	355	280
DM1-HV-AA 400 LY		500	400	
DM1-HV-AA 400 LZ		560		
DM1-HV-AA 450 M		630	450	315
DM1-HV-AA 450 MX		710	500	355
DM1-HV-AA 450 L		800	560	400
DM1-HV-AA 450 LX		900	630	450
DM1-HV-AA 450 LY				
DM1-HV-AA 500 M		1.000	710	500
DM1-HV-AA 500 MX		1.120	800	560
DM1-HV-AA 500 L		1.250	900	630
DM1-HV-AA 500 LX				
DM1-HV-AA 500 LY				
DM1-HV-AA 560 M		1.600	1.120	800
DM1-HV-AA 560 MX		1.800	1.250	900
DM1-HV-AA 560 L		2.000	1.400	1.000
DM1-HV-AA 560 LX				
DM1-HV-AA 630 M		2.240	1.600	1.120
DM1-HV-AA 630 MX		2.500	1.800	1.250
DM1-HV-AA 630 L		2.800	2.000	1.400
DM1-HV-AA 630 LX				1.600

DUTCHI MOTOR type DM1-HV = cast iron series 1, Medium & High Voltage frame size Baugröße hauteur d'axe tamaño de carcassa IEC-DIN	rated output power	rated output power	rated output power	rated output power
	2 - Pole; Polig; P.ôle; Polos - 3000 min ⁻¹	4 - Pole; Polig; P.ôle; Polos - 1500 min ⁻¹	6 - Pole; Polig; P.ôle; Polos - 1000 min ⁻¹	8 - Pole; Polig; P.ôle; Polos - 750 min ⁻¹
	P _N kW	P _N kW	P _N kW	P _N kW
DM1-HV-ODP 355 M	220	220	220	
DM1-HV-ODP 355 MX	250	250		
DM1-HV-ODP 355 MY	280			
DM1-HV-ODP 355 L	315	280	250	
DM1-HV-ODP 355 LX	355	315		
DM1-HV-ODP 355 LY	400			
DM1-HV-ODP 355 LZ				
DM1-HV-ODP 400 M	450	355	280	220
DM1-HV-ODP 400 MX	500			
DM1-HV-ODP 400 L	560	400	315	250
DM1-HV-ODP 400 LX	630	450	355	280
DM1-HV-ODP 400 LY		500	400	
DM1-HV-ODP 400 LZ		560		
DM1-HV-ODP 450 M		630	450	315
DM1-HV-ODP 450 MX		710	500	355
DM1-HV-ODP 450 L		800	560	400
DM1-HV-ODP 450 LX		900	630	450
DM1-HV-ODP 450 LY				
DM1-HV-ODP 500 M		1.000	710	500
DM1-HV-ODP 500 MX		1.120	800	560
DM1-HV-ODP 500 L		1.250	900	630
DM1-HV-ODP 500 LX				
DM1-HV-ODP 500 LY				
DM1-HV-ODP 560 M		1.600	1.120	800
DM1-HV-ODP 560 MX		1.800	1.250	900
DM1-HV-ODP 560 L		2.000	1.400	1.000
DM1-HV-ODP 560 LX				
DM1-HV-ODP 630 M		2.240	1.600	1.120
DM1-HV-ODP 630 MX		2.500	1.800	1.250
DM1-HV-ODP 630 L		2.800	2.000	1.400
DM1-HV-ODP 630 LX				1.600

